

# **QUARTZ CRYSTAL RESONATORS AND OSCILLATORS**

For Frequency Control and Timing Applications  
**A Tutorial**

**John R. Vig**

U.S. Army Communications-Electronics Command  
Attn: AMSEL-RD-C2-PT  
Fort Monmouth, NJ 07703, USA

**J.Vig@IEEE.org**

**January 2001**

Approved for public release.  
Distribution is unlimited.

## NOTICES

### **Disclaimer**

The findings in this report are not to be construed as an official Department of the Army position, unless so designated by other authorized documents.

The citation of trade names and names of manufacturers in this report is not to be construed as official Government endorsement or consent or approval of commercial products or services referenced herein.

# Report Documentation Page

REPORT DOCUMENTATION PAGE			Form Approved OMB NO. 0704-0188
<small>Public reporting burden for this collection of information is estimated to average 1 hour per response including the time for reviewing instructions, searching existing data sources, gathering and maintaining the data needed, and completing and reviewing the collection of information. Send comment regarding this burden estimate or any other aspect of this collection of information including suggestions for reducing this burden to Washington Headquarters Services, Directorate for Information Operations and Reports, 1215 Jefferson Davis Highway, Suite 1204, Arlington, VA 22202-4302, and to the Office of Management and Budget, Paperwork Reduction Project (0704-0188), Washington, DC 20503.</small>			
1. AGENCY USE ONLY (Leave blank)	2. REPORT DATE September 1997	3. REPORT TYPE AND DATES COVERED Technical Report	
4. TITLE AND SUBTITLE Quartz Crystal Resonators and Oscillators for Frequency Control and Timing Applications - A Tutorial		5. FUNDING NUMBERS PE: 1L1 PR: 62705 TA: AH94	
6. AUTHOR(S) John R. Vig		7. PERFORMING ORGANIZATION NAMES(S) AND ADDRESS(ES) U.S. Army Communications-Electronics Command (CECOM) ATTN: AMSEL-RD-C2 Fort Monmouth, NJ 07703, USA	
8. PERFORMING ORGANIZATION REPORT NUMBER SLCET-TR-88-1 (Rev. 8.0)		9. SPONSORING / MONITORING AGENCY NAME(S) AND ADDRESS(ES)	
10. SPONSORING / MONITORING AGENCY REPORT NUMBER		11. SUPPLEMENTARY NOTES This report is a slight revision of Technical Report SLCET-TR-88-1 (Rev.7.4, same title, dated May 1997).	
12a. DISTRIBUTION / AVAILABILITY STATEMENT Approved for public release. Distribution is unlimited.		12 b. DISTRIBUTION CODE	
13. ABSTRACT(Maximum 200 words) Subjects covered include: applications of oscillators and clocks; types of oscillators (quartz and atomic); quartz resonator properties; quartz growing, sweeping, and material characteristics; Q and its significance; resonator and oscillator stability, including aging, short-term stability, frequency vs. temperature characteristics, oscillator circuit caused instabilities, frequency vs. drive level effects, acceleration effects, the effect of shock, and radiation effects; emerging technologies; atomic frequency standards; comparison of the major oscillator types; oscillator specifications and selection guidelines; time and timekeeping; clock errors; relativistic time; time transfer; time and frequency subsystem; and other applications of quartz resonators.  The goal of this document is to assist in presenting to the nonspecialist the most frequently encountered concepts in frequency control and timing. The document originated as a set of "hard copies" of presentation visuals (i.e., vu-graphs).			
14. SUBJECT TERMS Quartz crystal, quartz resonator, quartz oscillator, oscillator, stability, phase noise, frequency control, frequency standard, clock, atomic clock, atomic standard, rubidium standard, cesium standard, vibration effects, radiation effects, time, timekeeping, GPS.		15. NUMBER OF PAGES 289	
17. SECURITY CLASSIFICATION OF REPORT Unclassified		16. PRICE CODE	
18. SECURITY CLASSIFICATION OF THIS PAGE Unclassified		19. SECURITY CLASSIFICATION OF ABSTRACT Unclassified	
20. LIMITATION OF ABSTRACT UL			

NSN 7540-01-280-5500

Standard Form 298 (Rev. 2-89)  
Prescribed by ANSI Std. Z39-18  
298-102

# Table of Contents

<u>Preface</u> .....	v
1. <u>Applications and Requirements</u> .....	1
2. <u>Quartz Crystal Oscillators</u> .....	2
3. <u>Quartz Crystal Resonators</u> .....	3
4. <u>Oscillator Stability</u> .....	4
5. <u>Quartz Material Properties</u> .....	5
6. <u>Atomic Frequency Standards</u> .....	6
7. <u>Oscillator Comparison and Specification</u> .....	7
8. <u>Time and Timekeeping</u> .....	8
9. <u>Related Devices and Applications</u> .....	9
10. <u>FCS Proceedings Ordering, Website, and Index</u> .....	10

## Preface

# Why This Tutorial?

“Everything should be made as simple as possible - but not simpler,” said Einstein. The main goal of this “tutorial” is to assist with presenting the most frequently encountered concepts in frequency control and timing, as simply as possible.

I have often been called upon to brief visitors, management, and potential users of precision oscillators, and have also been invited to present seminars, tutorials, and review papers before university, IEEE, and other professional groups. In the beginning, I spent a great deal of time preparing these presentations. Much of the time was spent on preparing the slides. As I accumulated more and more slides, it became easier and easier to prepare successive presentations.

I was frequently asked for “hard-copies” of the slides, so I started organizing, adding some text, and filling the gaps in the slide collection. As the collection grew, I began receiving favorable comments and requests for additional copies. Apparently, others, too, found this collection to be useful. Eventually, I assembled this document, the “Tutorial”.

This is a work in progress. I plan to include new material, including additional notes. Comments, corrections, and suggestions for future revisions will be welcome.

John R. Vig

# Notes and References

In the PowerPoint version of this document, notes and references can be found in the “Notes” of most of the pages. To view the notes, use the “Notes Page View” icon (near the lower left corner of the screen), or select “Notes Page” in the View menu. In PowerPoint 2000 (and, presumably, later versions), the notes also appear in the “Normal view”.

To print a page so that it includes the notes, select Print in the File menu, and, near the bottom, at “Print what:,” select “Notes Pages”.

The HTML version can be viewed with a web browser (best viewed at 1024 x 768 screen size). The notes then appear in the lower pane on the right.

Many of the references are to IEEE publications that are available online in the IEEE UFFC-S digital archive, [www.ieee-uffc.org/archive](http://www.ieee-uffc.org/archive) or in IEEE Xplore, <http://www.ieee.org/ieeexplore> .

**CHAPTER 1**  
**Applications and Requirements**

# Electronics Applications of Quartz Crystals

<p><b><u>Military &amp; Aerospace</u></b>            Communications            Navigation            IFF            Radar            Sensors            Guidance systems            Fuzes            Electronic warfare            Sonobouys</p>	<p><b><u>Industrial</u></b>            Communications            Telecommunications            Mobile/cellular/portable            radio, telephone &amp; pager            Aviation            Marine            Navigation            Instrumentation            Computers            Digital systems            CRT displays            Disk drives            Modems            Tagging/identification            Utilities            Sensors</p>	<p><b><u>Consumer</u></b>            Watches &amp; clocks            Cellular &amp; cordless            phones, pagers            Radio &amp; hi-fi equipment            Color TV            Cable TV systems            Home computers            VCR &amp; video camera            CB &amp; amateur radio            Toys &amp; games            Pacemakers            Other medical devices</p>
<p><b><u>Research &amp; Metrology</u></b>            Atomic clocks            Instruments            Astronomy &amp; geodesy            Space tracking            Celestial navigation</p>		<p><b><u>Automotive</u></b>            Engine control, stereo,            clock            Trip computer, GPS</p>



# Frequency Control Device Market

(as of ~1997)

Technology	Units per year	Unit price, typical	Worldwide market, \$/year
<u>Crystal</u>	$\sim 2 \times 10^9$	~\$1 (\$0.1 to 3,000)	~\$1.2B
<u>Atomic Frequency Standards</u> (see chapter 6)			
Hydrogen maser	~ 10	\$200,000	\$2M
Cesium beam frequency standard	~ 300	\$50,000	\$15M
Rubidium cell frequency standard	~ 20,000	\$2,000	\$40M

# Navigation

Precise time is essential to precise navigation. Historically, navigation has been a principal motivator in man's search for better clocks. Even in ancient times, one could measure latitude by observing the stars' positions. However, to determine longitude, the problem became one of timing. Since the earth makes one revolution in 24 hours, one can determine longitude from the time difference between local time (which was determined from the sun's position) and the time at the Greenwich meridian (which was determined by a clock):

**Longitude in degrees = (360 degrees/24 hours) x t in hours.**

In 1714, the British government offered a reward of 20,000 pounds to the first person to produce a clock that allowed the determination of a ship's longitude to 30 nautical miles at the end of a six week voyage (i.e., a clock accuracy of three seconds per day). The Englishman John Harrison won the competition in 1735 for his chronometer invention.

Today's electronic navigation systems still require ever greater accuracies. As electromagnetic waves travel 300 meters per microsecond, e.g., if a vessel's timing was in error by one millisecond, a navigational error of 300 kilometers would result. In the Global Positioning System (GPS), atomic clocks in the satellites and quartz oscillators in the receivers provide nanosecond-level accuracies. The resulting (worldwide) navigational accuracies are about ten meters (see chapter 8 for further details about GPS).

# Commercial Two-way Radio

Historically, as the number of users of commercial two-way radios have grown, channel spacings have been narrowed, and higher-frequency spectra have had to be allocated to accommodate the demand. Narrower channel spacings and higher operating frequencies necessitate tighter frequency tolerances for both the transmitters and the receivers. In 1940, when only a few thousand commercial broadcast transmitters were in use, a 500 ppm tolerance was adequate. Today, the oscillators in the many millions of cellular telephones (which operate at frequency bands above 800 MHz) must maintain a frequency tolerance of 2.5 ppm and better. The 896-901 MHz and 935-940 MHz mobile radio bands require frequency tolerances of 0.1 ppm at the base station and 1.5 ppm at the mobile station.

The need to accommodate more users will continue to require higher and higher frequency accuracies. For example, a NASA concept for a personal satellite communication system would use walkie-talkie-like hand-held terminals, a 30 GHz uplink, a 20 GHz downlink, and a 10 kHz channel spacing. The terminals' frequency accuracy requirement is a few parts in  $10^8$ .

# Digital Processing of Analog Signals

## The Effect of Timing Jitter

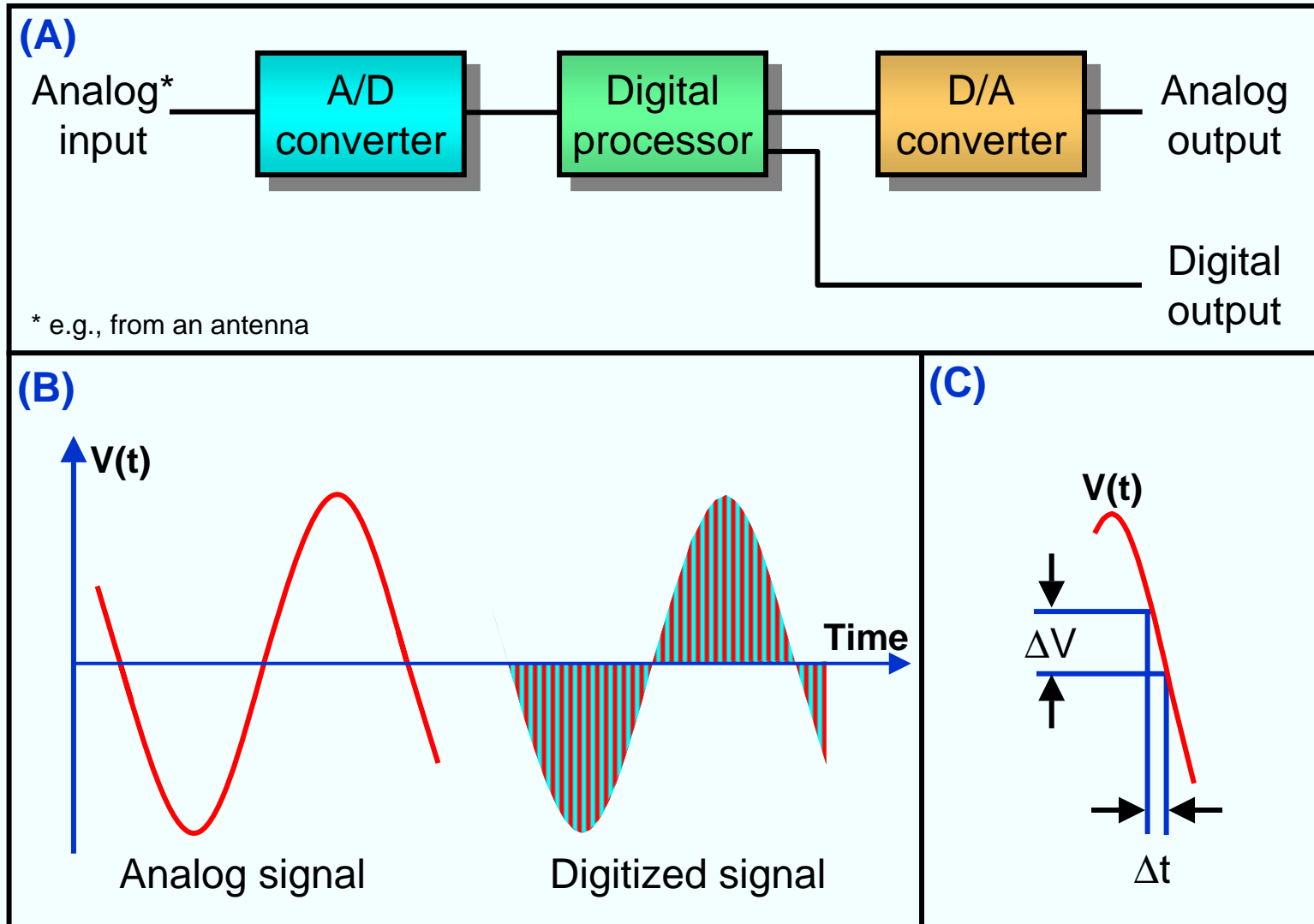

# Digital Network Synchronization

- Synchronization plays a critical role in digital telecommunication systems. It ensures that information transfer is performed with minimal buffer overflow or underflow events, i.e., with an acceptable level of "slips." Slips cause problems, e.g., missing lines in FAX transmission, clicks in voice transmission, loss of encryption key in secure voice transmission, and data retransmission.
- In AT&T's network, for example, timing is distributed down a hierarchy of nodes. A timing source-receiver relationship is established between pairs of nodes containing clocks. The clocks are of four types, in four "stratum levels."

Stratum	Accuracy (Free Running)		Clock Type	Number Used
	Long Term	Per 1st Day		
1	$1 \times 10^{-11}$	N.A.	GPS W/Two Rb	16
2	$1.6 \times 10^{-8}$	$1 \times 10^{-10}$	Rb Or OCXO	~200
3	$4.6 \times 10^{-6}$	$3.7 \times 10^{-7}$	OCXO Or TCXO	1000's
4	$3.2 \times 10^{-5}$	N.A.	XO	~1 million

# Phase Noise in PLL and PSK Systems

The phase noise of oscillators can lead to erroneous detection of phase transitions, i.e., to bit errors, when phase shift keyed (PSK) digital modulation is used. In digital communications, for example, where 8-phase PSK is used, the maximum phase tolerance is  $\pm 22.5^\circ$ , of which  $\pm 7.5^\circ$  is the typical allowable carrier noise contribution. Due to the statistical nature of phase deviations, if the RMS phase deviation is  $1.5^\circ$ , for example, the probability of exceeding the  $\pm 7.5^\circ$  phase deviation is  $6 \times 10^{-7}$ , which can result in a bit error rate that is significant in some applications.

Shock and vibration can produce large phase deviations even in "low noise" oscillators. Moreover, when the frequency of an oscillator is multiplied by  $N$ , the phase deviations are also multiplied by  $N$ . For example, a phase deviation of  $10^{-3}$  radian at 10 MHz becomes 1 radian at 10 GHz. Such large phase excursions can be catastrophic to the performance of systems, e.g., of those which rely on phase locked loops (PLL) or phase shift keying (PSK). Low noise, acceleration insensitive oscillators are essential in such applications.

# Utility Fault Location

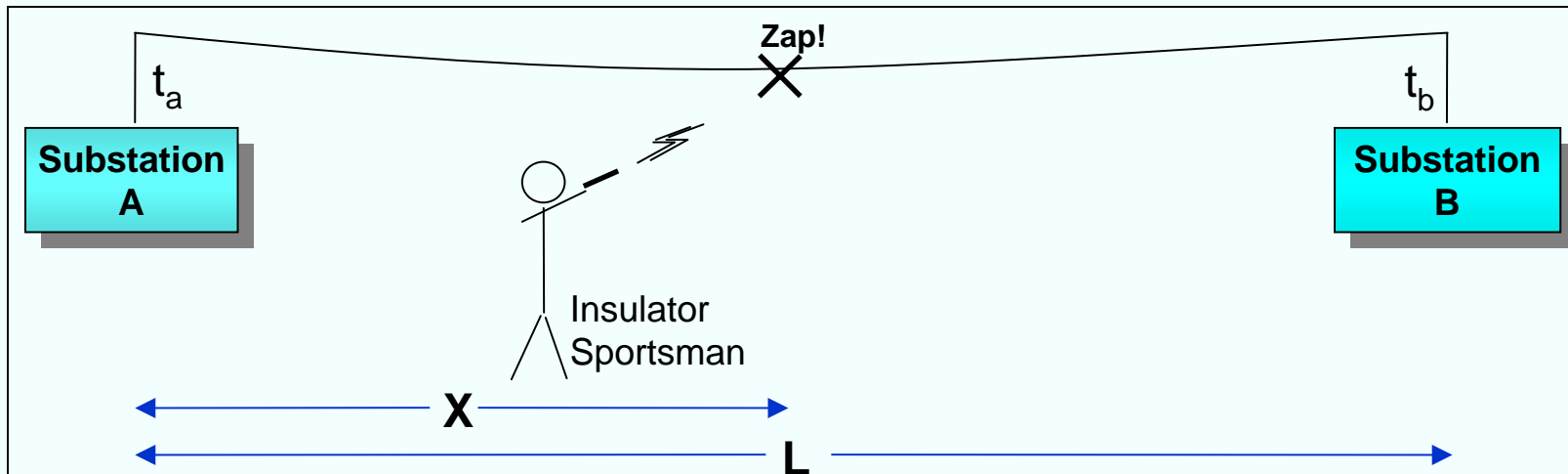

When a fault occurs, e.g., when a "sportsman" shoots out an insulator, a disturbance propagates down the line. The location of the fault can be determined from the differences in the times of arrival at the nearest substations:

$$x = 1/2[L - c(t_b - t_a)] = 1/2[L - c\Delta t]$$

where  $x$  = distance of the fault from substation A,  $L$  = A to B line length,  $c$  = speed of light, and  $t_a$  and  $t_b$  = time of arrival of disturbance at A and B, respectively.

Fault locator error =  $x_{\text{error}} = 1/2(c\Delta t_{\text{error}})$ ; therefore, if  $\Delta t_{\text{error}} \leq 1$  microsecond, then  $x_{\text{error}} \leq 150$  meters  $\leq 1/2$  of high voltage tower spacings, so, the utility company can send a repair crew directly to the tower that is nearest to the fault.

# Space Exploration

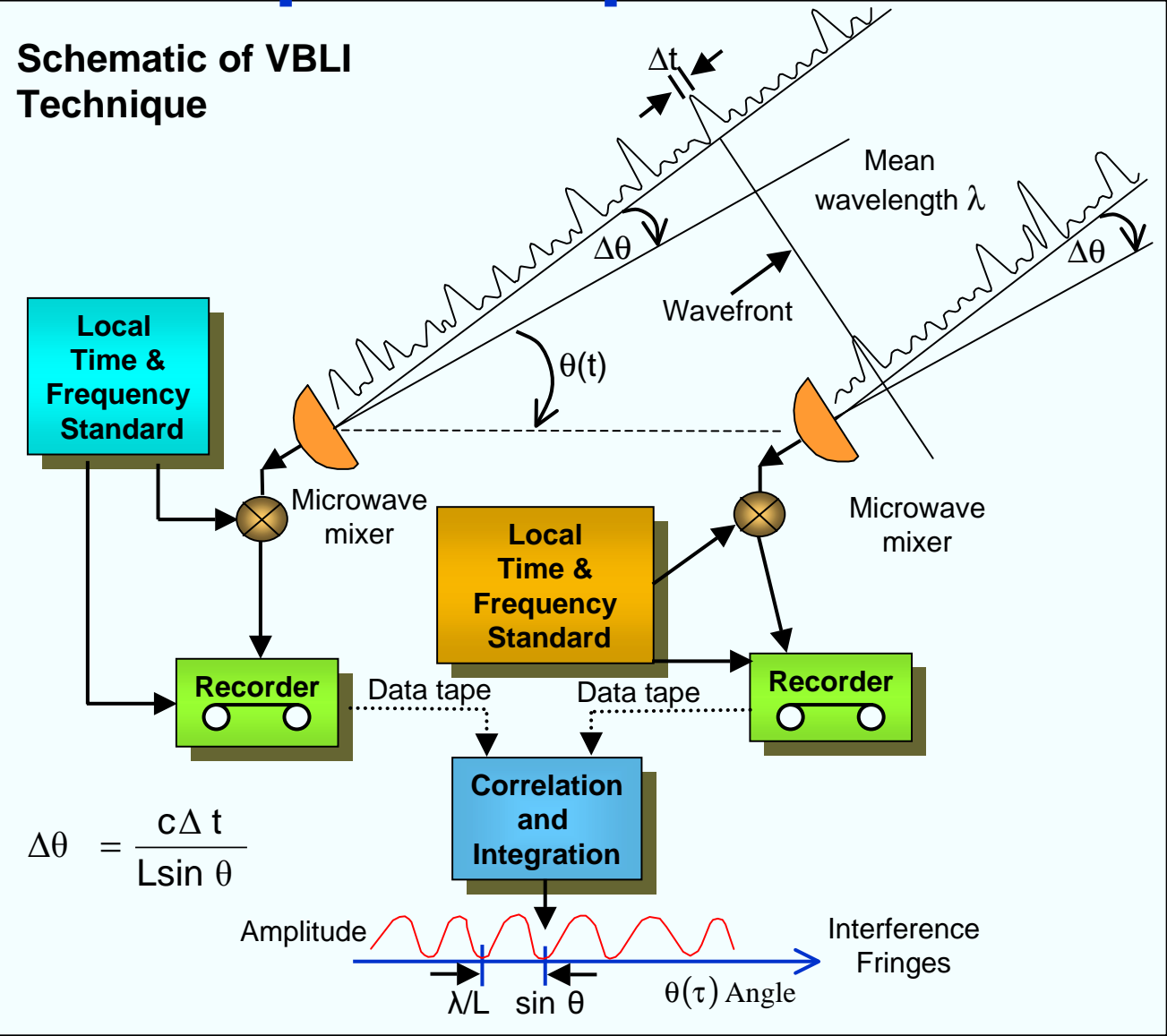



# Military Requirements

Military needs are a prime driver of frequency control technology. Modern military systems require oscillators/clocks that are:

- Stable over a wide range of parameters (time, temperature, acceleration, radiation, etc.)
- Low noise
- Low power
- Small size
- Fast warmup
- Low life-cycle cost

# Impacts of Oscillator Technology Improvements

- Higher jamming resistance & improved ability to hide signals
- Improved ability to deny use of systems to unauthorized users
- Longer autonomy period (radio silence interval)
- Fast signal acquisition (net entry)
- Lower power for reduced battery consumption
- Improved spectrum utilization
- Improved surveillance capability (e.g., slow-moving target detection, bistatic radar)
- Improved missile guidance (e.g., on-board radar vs. ground radar)
- Improved identification-friend-or-foe (IFF) capability
- Improved electronic warfare capability (e.g., emitter location via TOA)
- Lower error rates in digital communications
- Improved navigation capability
- Improved survivability and performance in radiation environment
- Improved survivability and performance in high shock applications
- Longer life, and smaller size, weight, and cost
- Longer recalibration interval (lower logistics costs)

# Spread Spectrum Systems

- In a spread spectrum system, the transmitted signal is spread over a bandwidth that is much wider than the bandwidth required to transmit the information being sent (e.g., a voice channel of a few kHz bandwidth is spread over many MHz). This is accomplished by modulating a carrier signal with the information being sent, using a wideband pseudonoise (PN) encoding signal. A spread spectrum receiver with the appropriate PN code can demodulate and extract the information being sent. Those without the PN code may completely miss the signal, or if they detect the signal, it appears to them as noise.
- Two of the spread spectrum modulation types are: 1. direct sequence, in which the carrier is modulated by a digital code sequence, and 2. frequency hopping, in which the carrier frequency jumps from frequency to frequency, within some predetermined set, the order of frequencies being determined by a code sequence.
- Transmitter and receiver contain **clocks** which must be synchronized; e.g., in a frequency hopping system, the transmitter and receiver must hop to the same frequency at the same time. The faster the hopping rate, the higher the jamming resistance, and the more accurate the clocks must be (see the next page for an example).
- Advantages of spread spectrum systems include the following capabilities: 1. rejection of intentional and unintentional jamming, 2. low probability of intercept (LPI), 3. selective addressing, 4. multiple access, and 5. high accuracy navigation and ranging.

# Clock for Very Fast Frequency Hopping Radio

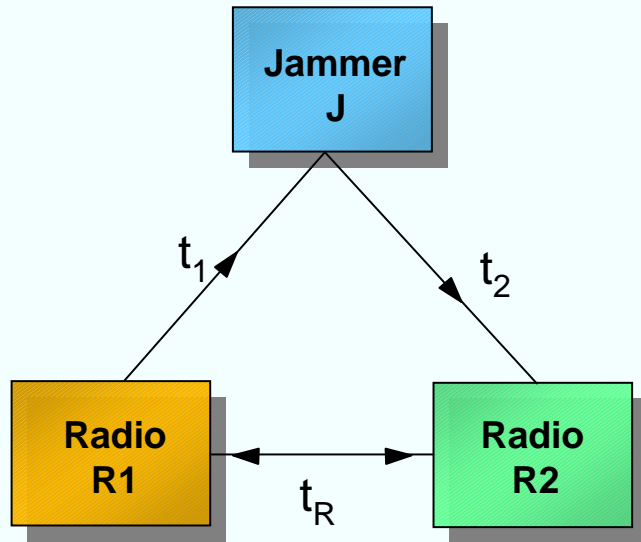

To defeat a “perfect” follower jammer, one needs a hop-rate given by:

$$t_m < (t_1 + t_2) - t_R$$

where  $t_m \approx$  message duration/hop  
 $\approx 1/\text{hop-rate}$

## Example

Let R1 to R2 = 1 km, R1 to J = 5 km, and J to R2 = 5 km. Then, since propagation delay = 3.3  $\mu\text{s}/\text{km}$ ,

$$t_1 = t_2 = 16.5 \mu\text{s},$$

$$t_R = 3.3 \mu\text{s}, \text{ and } t_m < 30 \mu\text{s}.$$

Allowed clock error  $\approx 0.2 t_m$   
 $\approx 6 \mu\text{s}.$

For a 4 hour resynch interval, clock accuracy requirement is:

$$4 \times 10^{-10}$$

# Clocks and Frequency Hopping C<sup>3</sup> Systems

Slow hopping ‹-----› Good clock

Fast hopping ‹-----› Better clock

Extended radio silence ‹-----› Better clock

Extended calibration interval ‹-----› Better clock

Othogonality ‹-----› Better clock

Interoperability ‹-----› Better clock

# Identification-Friend-Or-Foe (IFF)

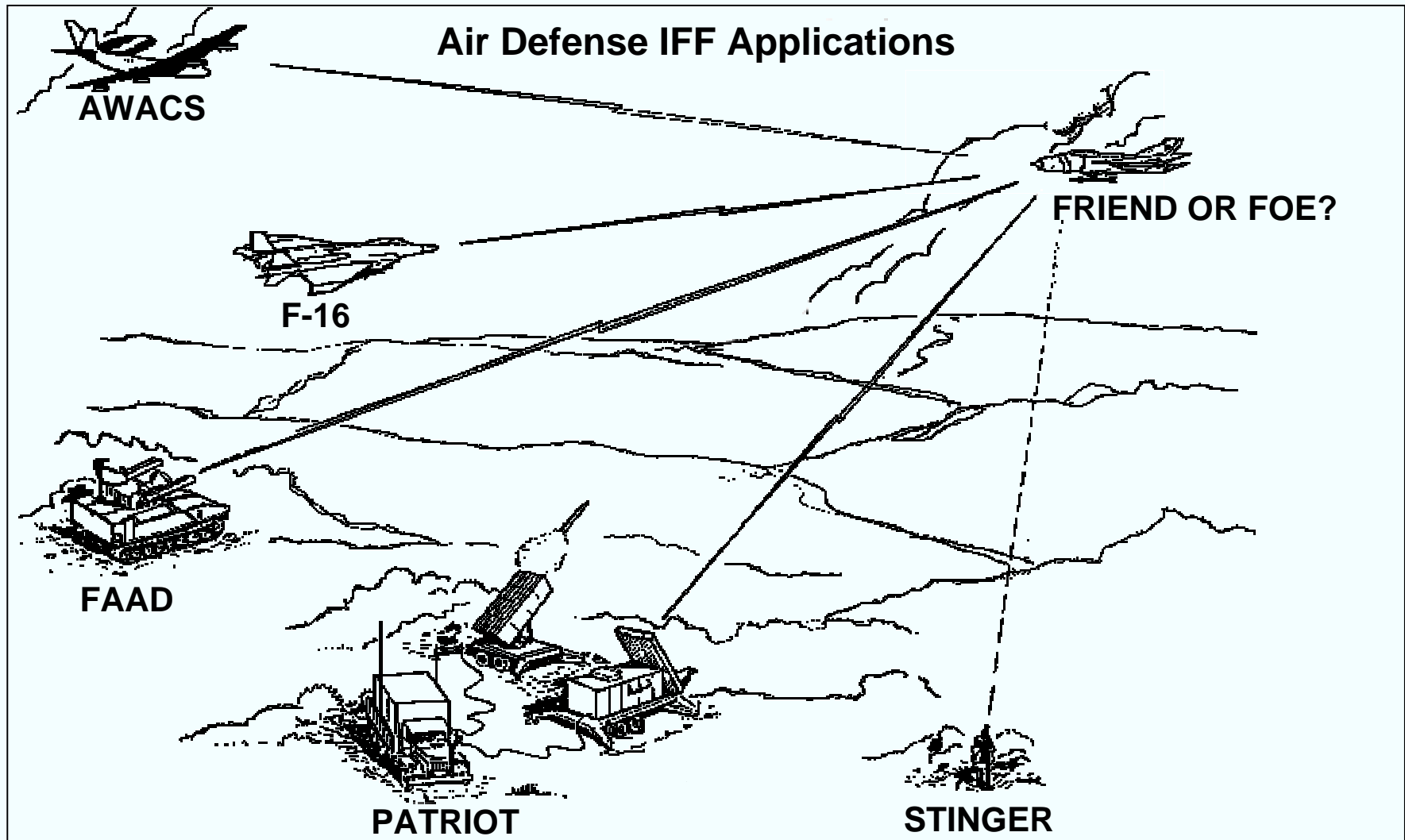

# Effect of Noise in Doppler Radar System

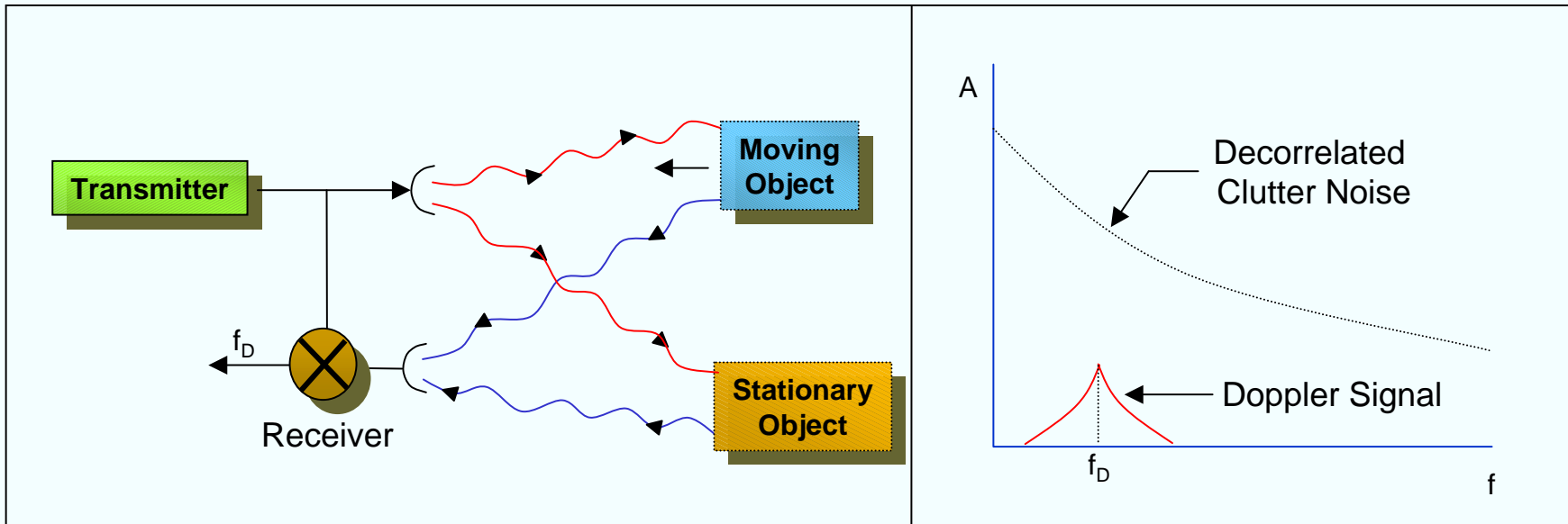

- Echo = Doppler-shifted echo from moving target + large "clutter" signal
- (Echo signal) - (reference signal) --> Doppler shifted signal from target
- Phase noise of the local oscillator modulates (decorrelates) the clutter signal, generates higher frequency clutter components, and thereby degrades the radar's ability to separate the target signal from the clutter signal.

# Bistatic Radar

Conventional (i.e., "monostatic") radar, in which the illuminator and receiver are on the same platform, is vulnerable to a variety of countermeasures. Bistatic radar, in which the illuminator and receiver are widely separated, can greatly reduce the vulnerability to countermeasures such as jamming and antiradiation weapons, and can increase slow moving target detection and identification capability via "clutter tuning" (receiver maneuvers so that its motion compensates for the motion of the illuminator; creates zero Doppler shift for the area being searched). The transmitter can remain far from the battle area, in a "sanctuary." The receiver can remain "quiet."

The timing and phase coherence problems can be orders of magnitude more severe in bistatic than in monostatic radar, especially when the platforms are moving. The reference oscillators must remain synchronized and syntonized during a mission so that the receiver knows when the transmitter emits each pulse, and the phase variations will be small enough to allow a satisfactory image to be formed. Low noise crystal oscillators are required for short term stability; atomic frequency standards are often required for long term stability.

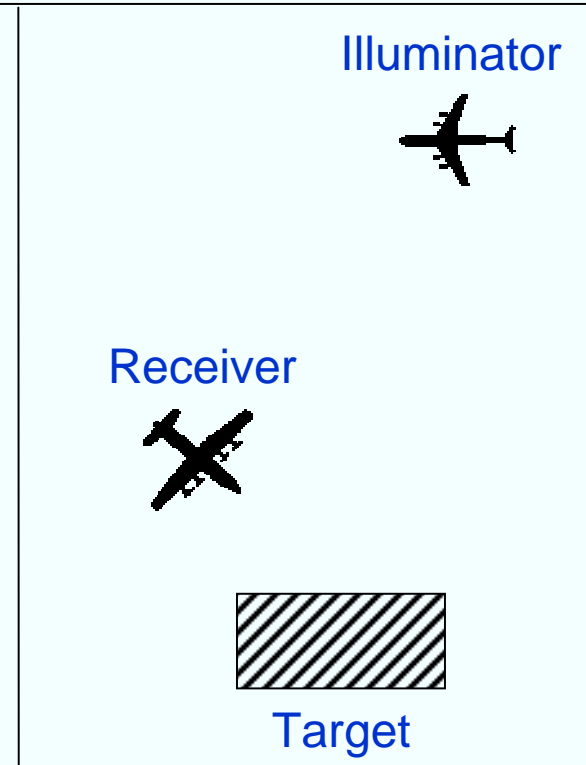



# Doppler Shifts

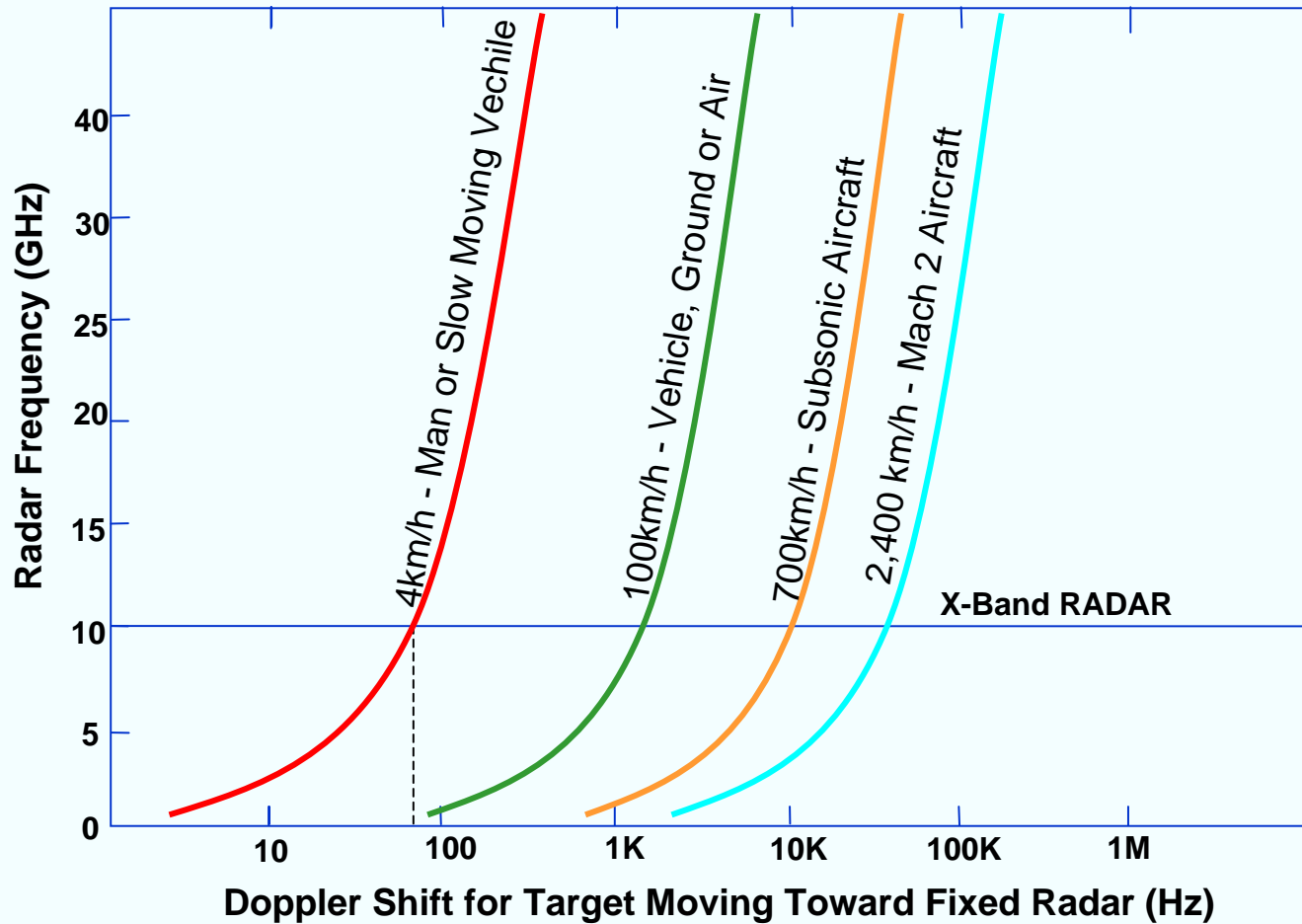

**CHAPTER 2**  
**Quartz Crystal Oscillators**

# Crystal Oscillator

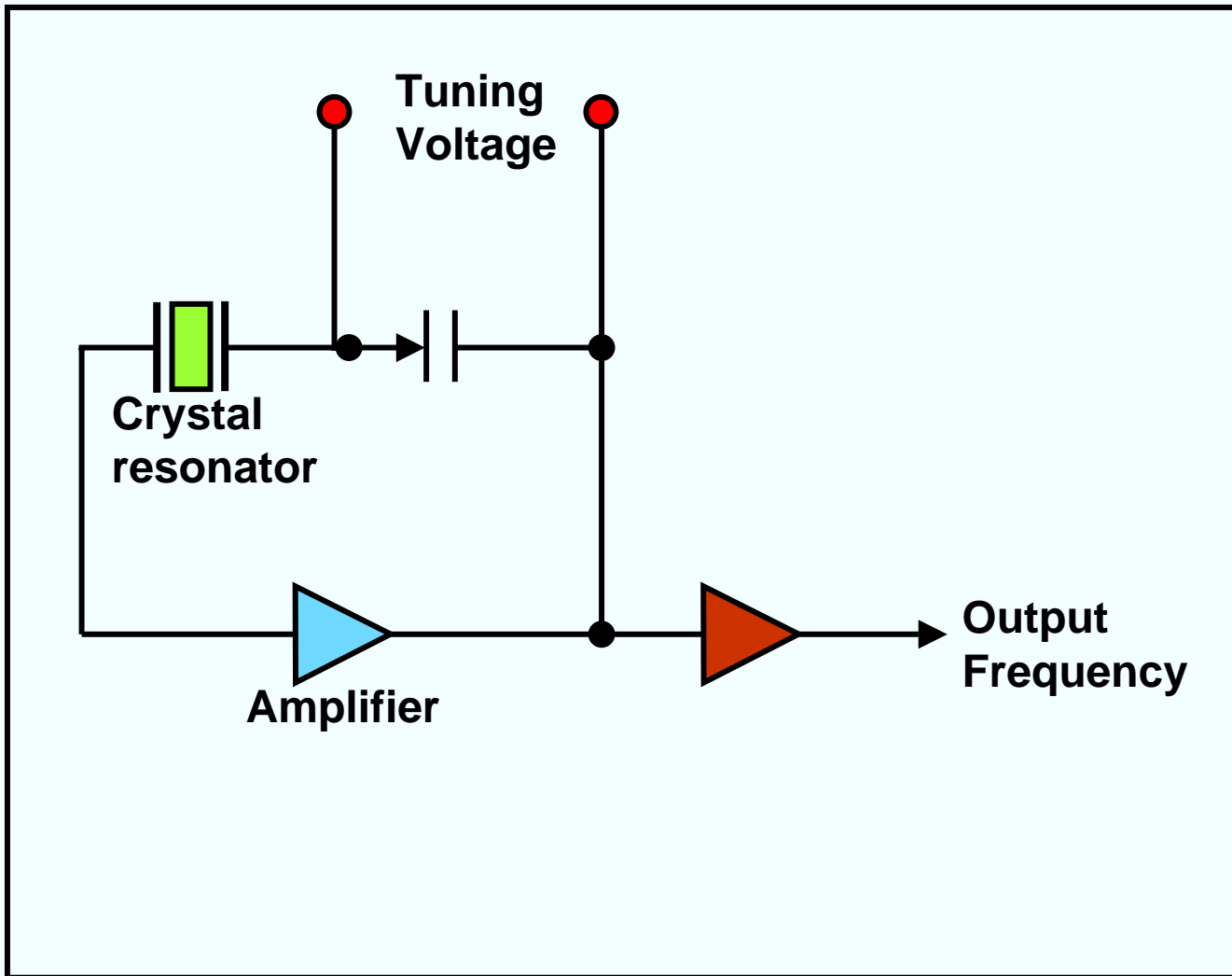

# Oscillation

- At the frequency of oscillation, the closed loop phase shift =  $2n\pi$ .
- When initially energized, the only signal in the circuit is noise. That component of noise, the frequency of which satisfies the phase condition for oscillation, is propagated around the loop with increasing amplitude. The rate of increase depends on the excess; i.e., small-signal, loop gain and on the BW of the crystal in the network.
- The amplitude continues to increase until the amplifier gain is reduced either by nonlinearities of the active elements ("self limiting") or by some automatic level control.
- At steady state, the closed-loop gain = 1.

# Oscillation and Stability

- If a phase perturbation  $\Delta\phi$  occurs, the frequency must shift  $\Delta f$  to maintain the  $2n\pi$  phase condition, where  $\Delta f/f = -\Delta\phi/2Q_L$  for a series-resonance oscillator, and  $Q_L$  is loaded Q of the crystal in the network. The "phase slope,"  $d\phi/df$  is proportional to  $Q_L$  in the vicinity of the series resonance frequency (also see "Equivalent Circuit" and "Frequency vs. Reactance" in Chapt. 3).
- Most oscillators operate at "parallel resonance," where the reactance vs. frequency slope,  $dX/df$ , i.e., the "stiffness," is inversely proportional to  $C_1$ , the motional capacitance of the crystal unit.
- For maximum frequency stability with respect to phase (or reactance) perturbations in the oscillator loop, the phase slope (or reactance slope) must be maximum, i.e.,  $C_1$  should be minimum and  $Q_L$  should be maximum. A quartz crystal unit's high Q and high stiffness makes it the primary frequency (and frequency stability) determining element in oscillators.

# Tunability and Stability

Making an oscillator tunable over a wide frequency range degrades its stability because making an oscillator susceptible to intentional tuning also makes it susceptible to factors that result in unintentional tuning. The wider the tuning range, the more difficult it is to maintain a high stability. For example, if an OCXO is designed to have a short term stability of  $1 \times 10^{-12}$  for some averaging time and a tunability of  $1 \times 10^{-7}$ , then the crystal's load reactance must be stable to  $1 \times 10^{-5}$  for that averaging time. Achieving such stability is difficult because the load reactance is affected by stray capacitances and inductances, by the stability of the varactor's capacitance vs. voltage characteristic, and by the stability of the voltage on the varactor. Moreover, the  $1 \times 10^{-5}$  load reactance stability must be maintained not only under benign conditions, but also under changing environmental conditions (temperature, vibration, radiation, etc.).

Whereas a high stability, ovenized 10 MHz voltage controlled oscillator may have a frequency adjustment range of  $5 \times 10^{-7}$  and an aging rate of  $2 \times 10^{-8}$  per year, a wide tuning range 10 MHz VCXO may have a tuning range of 50 ppm and an aging rate of 2 ppm per year.

# Oscillator Acronyms

- **XO**.....Crystal Oscillator
- **VCXO**.....Voltage Controlled Crystal Oscillator
- **OCXO**.....Oven Controlled Crystal Oscillator
- **TCXO**.....Temperature Compensated Crystal Oscillator
- **TCVCXO**.....Temperature Compensated/Voltage Controlled Crystal Oscillator
- **OCVCXO**.....Oven Controlled/Voltage Controlled Crystal Oscillator
- **MCXO**.....Microcomputer Compensated Crystal Oscillator
- **RbXO**.....Rubidium-Crystal Oscillator

# Crystal Oscillator Categories

The three categories, based on the method of dealing with the crystal unit's frequency vs. temperature (f vs. T) characteristic, are:

- **XO, crystal oscillator**, does not contain means for reducing the crystal's f vs. T characteristic (also called PXO-packaged crystal oscillator).
- **TCXO, temperature compensated crystal oscillator**, in which, e.g., the output signal from a temperature sensor (e.g., a thermistor) is used to generate a correction voltage that is applied to a variable reactance (e.g., a varactor) in the crystal network. The reactance variations compensate for the crystal's f vs. T characteristic. Analog TCXO's can provide about a 20X improvement over the crystal's f vs. T variation.
- **OCXO, oven controlled crystal oscillator**, in which the crystal and other temperature sensitive components are in a stable oven which is adjusted to the temperature where the crystal's f vs. T has zero slope. OCXO's can provide a >1000X improvement over the crystal's f vs. T variation.



# Crystal Oscillator Categories

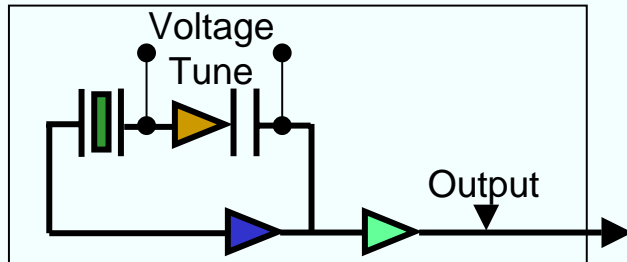

- Crystal Oscillator (XO)

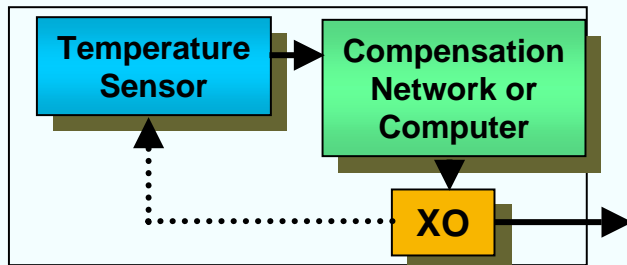
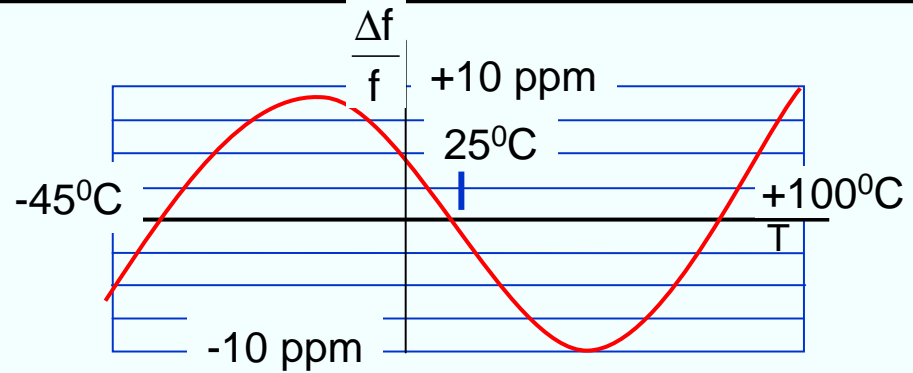

- Temperature Compensated (TCXO)

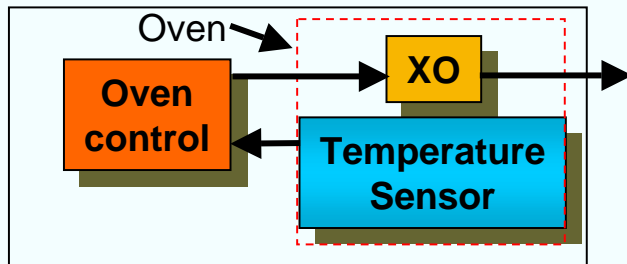
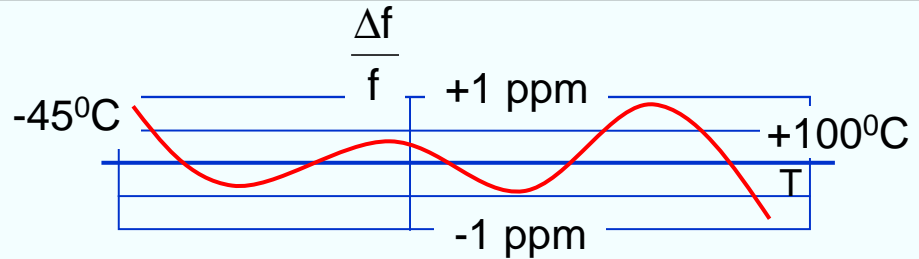

- Oven Controlled (OCXO)

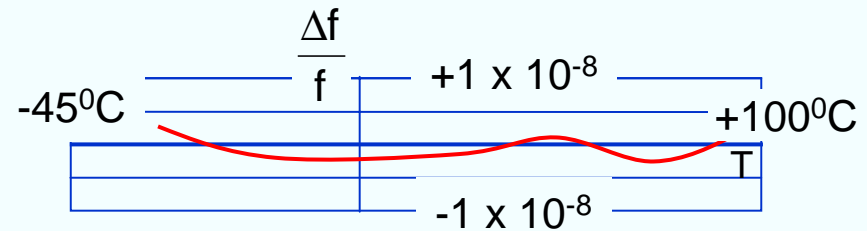

# Hierarchy of Oscillators

Oscillator Type*	Accuracy**	Typical Applications
<ul style="list-style-type: none"> <li>• Crystal oscillator (XO)</li> </ul>	$10^{-5}$ to $10^{-4}$	Computer timing
<ul style="list-style-type: none"> <li>• Temperature compensated crystal oscillator (TCXO)</li> </ul>	$10^{-6}$	Frequency control in tactical radios
<ul style="list-style-type: none"> <li>• Microcomputer compensated crystal oscillator (MCXO)</li> </ul>	$10^{-8}$ to $10^{-7}$	Spread spectrum system clock
<ul style="list-style-type: none"> <li>• Oven controlled crystal oscillator (OCXO)</li> </ul>	$10^{-8}$ (with $10^{-10}$ per g option)	Navigation system clock & frequency standard, MTI radar
<ul style="list-style-type: none"> <li>• Small atomic frequency standard (Rb, RbXO)</li> </ul>	$10^{-9}$	C <sup>3</sup> satellite terminals, bistatic, & multistatic radar
<ul style="list-style-type: none"> <li>• High performance atomic standard (Cs)</li> </ul>	$10^{-12}$ to $10^{-11}$	Strategic C <sup>3</sup> , EW

\* Sizes range from <math>5\text{cm}^3</math> for clock oscillators to > 30 liters for Cs standards  
 Costs range from <math>\\$5</math> for clock oscillators to > \$50,000 for Cs standards.

\*\* Including environmental effects (e.g.,  $-40^\circ\text{C}$  to  $+75^\circ\text{C}$ ) and one year of aging.

# Oscillator Circuit Types

Of the numerous oscillator circuit types, three of the more common ones, the Pierce, the Colpitts and the Clapp, consist of the same circuit except that the rf ground points are at different locations. The Butler and modified Butler are also similar to each other; in each, the emitter current is the crystal current. The gate oscillator is a Pierce-type that uses a logic gate plus a resistor in place of the transistor in the Pierce oscillator. (Some gate oscillators use more than one gate).

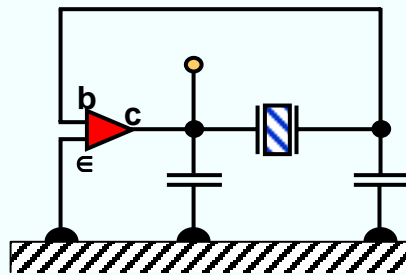

**Pierce**

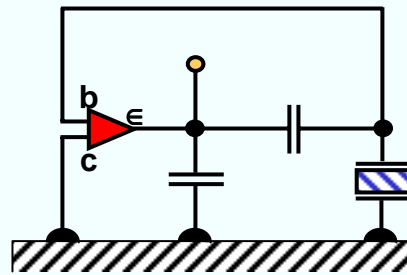

**Colpitts**

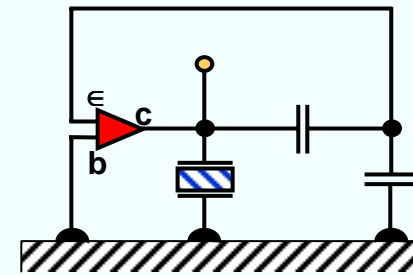

**Clapp**

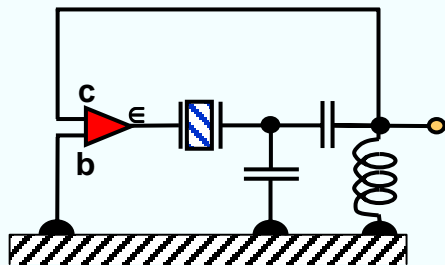

**Butler**

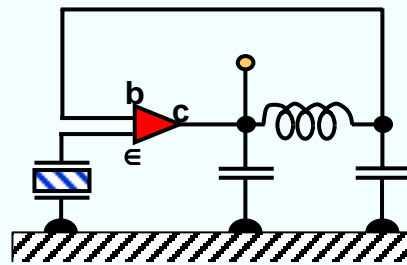

**Modified  
Butler**

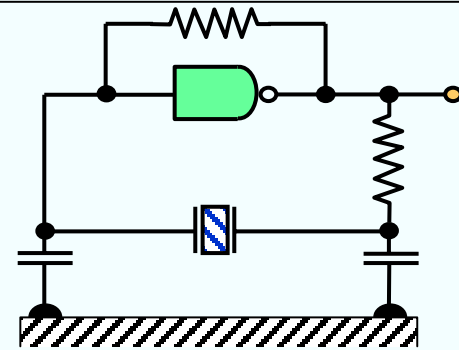

**Gate**

# OCXO Block Diagram

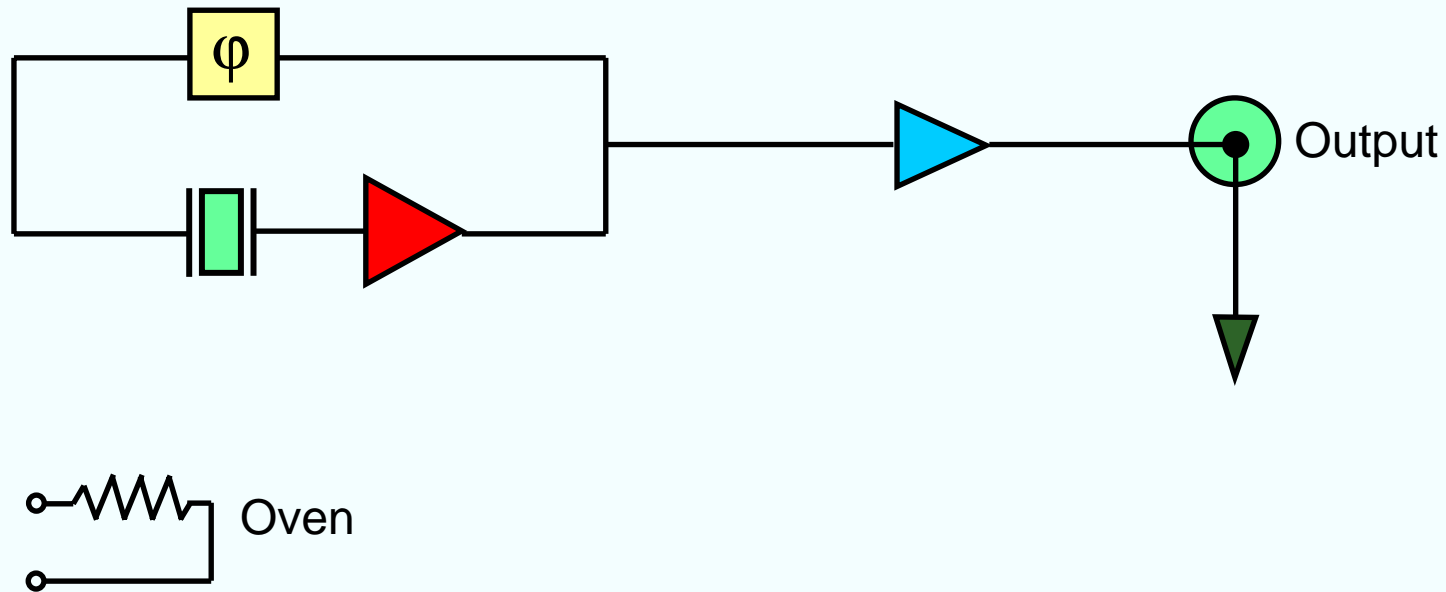

Each of the three main parts of an OCXO, i.e., the crystal, the sustaining circuit, and the oven, contribute to instabilities. The various instabilities are discussed in the rest of chapter 3 and in chapter 4.

# Oscillator Instabilities - General Expression

$$\frac{\Delta f}{f_{\text{oscillator}}} \approx \frac{\Delta f}{f_{\text{resonator}}} + \frac{1}{2Q_L} \left[ 1 + \left( \frac{2f_f Q_L}{f} \right)^2 \right]^{-1/2} d\phi(f_f)$$

where  $Q_L$  = loaded Q of the resonator, and  $d\phi(f_f)$  is a small change in loop phase at offset frequency  $f_f$  away from carrier frequency  $f$ . Systematic phase changes and phase noise within the loop can originate in either the resonator or the sustaining circuits. Maximizing  $Q_L$  helps to reduce the effects of noise and environmentally induced changes in the sustaining electronics. In a properly designed oscillator, the short-term instabilities are determined by the resonator at offset frequencies smaller than the resonator's half-bandwidth, and by the sustaining circuit and the amount of power delivered from the loop for larger offsets.

# Instabilities due to Sustaining Circuit

- **Load reactance change** - adding a load capacitance to a crystal changes the frequency by

$$\delta f \equiv \frac{\Delta f}{f} \cong \frac{C_1}{2(C_0 + C_L)}$$

$$\text{then, } \frac{\Delta(\delta f)}{\Delta C_L} \cong -\frac{C_1}{2(C_0 + C_L)^2}$$

- **Example:** If  $C_0 = 5 \text{ pF}$ ,  $C_1 = 14 \text{ fF}$  and  $C_L = 20 \text{ pF}$ , then a  $\Delta C_L = 10 \text{ fF}$  ( $= 5 \times 10^{-4}$ ) causes  $\approx 1 \times 10^{-7}$  frequency change, and a  $C_L$  aging of 10 ppm per day causes  $2 \times 10^{-9}$  per day of oscillator aging.
- **Drive level changes:** Typically  $10^{-8}$  per  $\text{ma}^2$  for a 10 MHz 3rd SC-cut.
- **DC bias** on the crystal also contributes to oscillator aging.

# Oscillator Instabilities - Tuned Circuits

Many oscillators contain tuned circuits - to suppress unwanted modes, as matching circuits, and as filters. The effects of small changes in the tuned circuit's inductance and capacitance is given by:

$$\frac{\Delta f}{f_{\text{oscillator}}} \approx \frac{d\phi(f_f)}{2Q_L} \approx \left( \frac{1}{1 + \frac{2f_f}{BW}} \right) \left( \frac{Q_c}{Q} \right) \left( \frac{dC_c}{C_c} + \frac{dL_c}{L_c} \right)$$

where BW is the bandwidth of the filter,  $f_f$  is the frequency offset of the center frequency of the filter from the carrier frequency,  $Q_L$  is the loaded Q of the resonator, and  $Q_c$ ,  $L_c$  and  $C_c$  are the tuned circuit's Q, inductance and capacitance, respectively.

# Oscillator Instabilities - Circuit Noise

Flicker PM noise in the sustaining circuit causes flicker FM contribution to the oscillator output frequency given by:

$$L_{\text{osc}}(f_f) = L_{\text{ckt}}(1\text{Hz}) \frac{f^2}{4f_f^3 Q_L^2}$$

and

$$\sigma_y(\tau) = \frac{1}{Q_L} \sqrt{\ln 2 L_{\text{ckt}}(1\text{Hz})}$$

where  $f_f$  is the frequency offset from the carrier frequency  $f$ ,  $Q_L$  is the loaded Q of the resonator in the circuit,  $L_{\text{ckt}}(1\text{Hz})$  is the flicker PM noise at  $f_f = 1\text{Hz}$ , and  $\tau$  is any measurement time in the flicker floor range. For  $Q_L = 10^6$  and  $L_{\text{ckt}}(1\text{Hz}) = -140\text{dBc/Hz}$ ,  $\sigma_y(\tau) = 8.3 \times 10^{-14}$ . ( $L_{\text{ckt}}(1\text{Hz}) = -155\text{dBc/Hz}$  has been achieved.)



# Oscillator Instabilities - External Load

If the external load changes, there is a change in the amplitude or phase of the signal reflected back into the oscillator. The portion of that signal which reaches the oscillating loop changes the oscillation phase, and hence the frequency by

$$\frac{\Delta f}{f_{\text{oscillator}}} \approx \frac{d\phi(f_f)}{2Q} \approx \left( \frac{1}{2Q} \right) \left( \frac{\Gamma - 1}{\Gamma + 1} \right) (\sin\theta) \sqrt{\text{isolation}}$$

where  $\Gamma$  is the VSWR of the load, and  $\theta$  is the phase angle of the reflected wave; e.g., if  $Q \sim 10^6$ , and isolation  $\sim 40$  dB (i.e.,  $\sim 10^{-4}$ ), then the worst case (100% reflection) pulling is  $\sim 5 \times 10^{-9}$ . A VSWR of 2 reduces the maximum pulling by only a factor of 3. The problem of load pulling becomes worse at higher frequencies, because both the  $Q$  and the isolation are lower.

# Oscillator Outputs

Most users require a sine wave, a TTL-compatible, a CMOS-compatible, or an ECL-compatible output. The latter three can be simply generated from a sine wave. The four output types are illustrated below, with the dashed lines representing the supply voltage inputs, and the bold solid lines, the outputs. (There is no “standard” input voltage for sine wave oscillators, and the input voltage for CMOS typically ranges from 3V to 15V.)

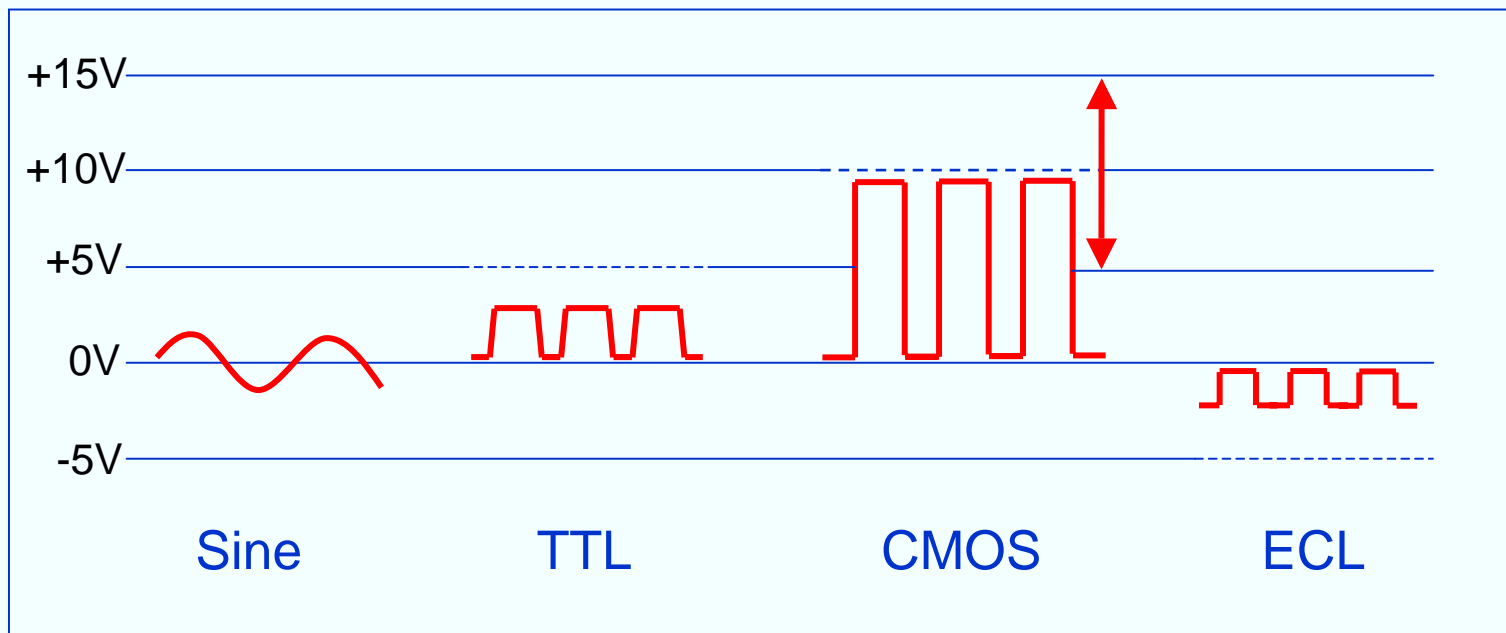

# Resonator Self-Temperature Sensing

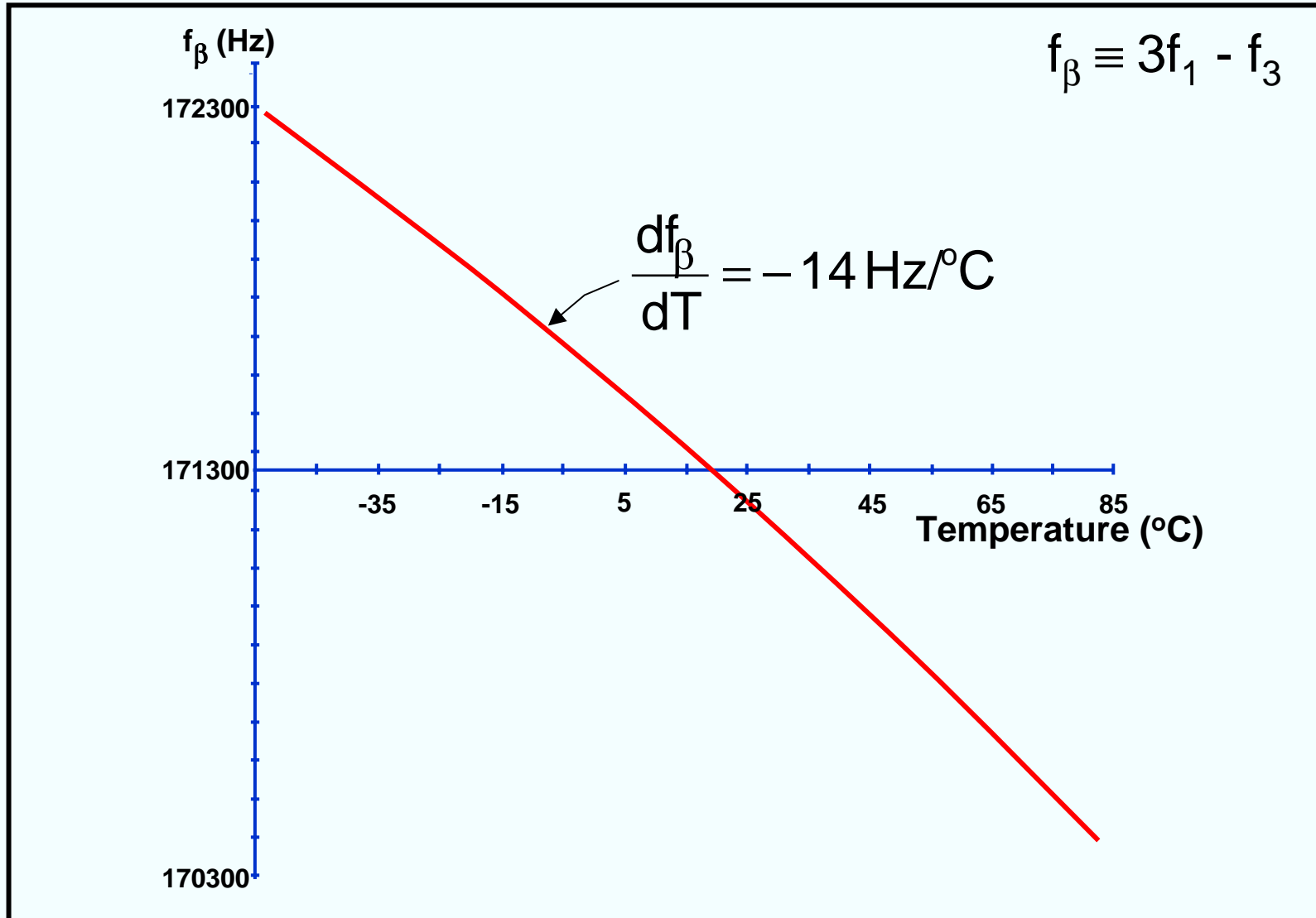

# Thermometric Beat Frequency Generation

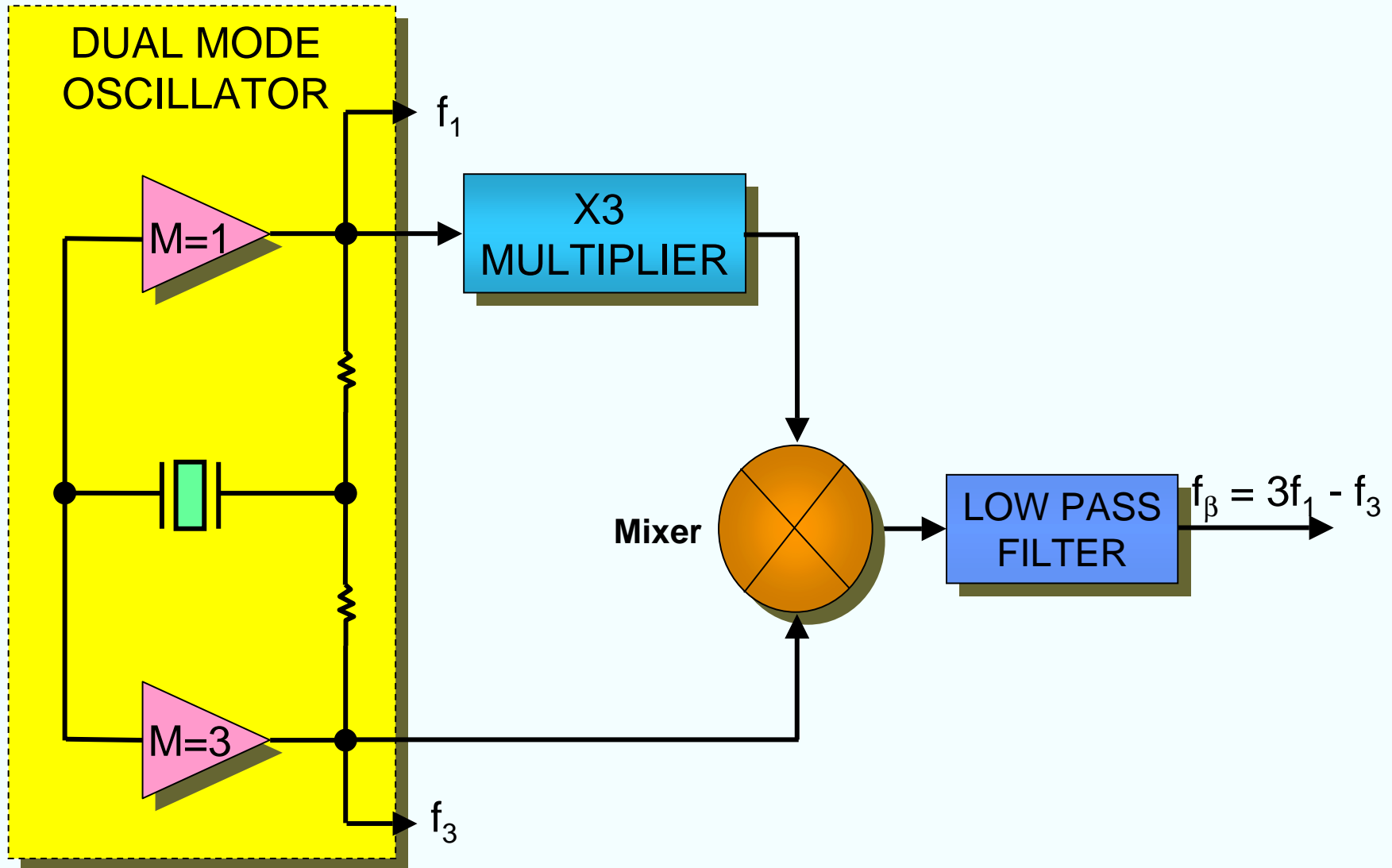

# Microcomputer Compensated Crystal Oscillator (MCXO)

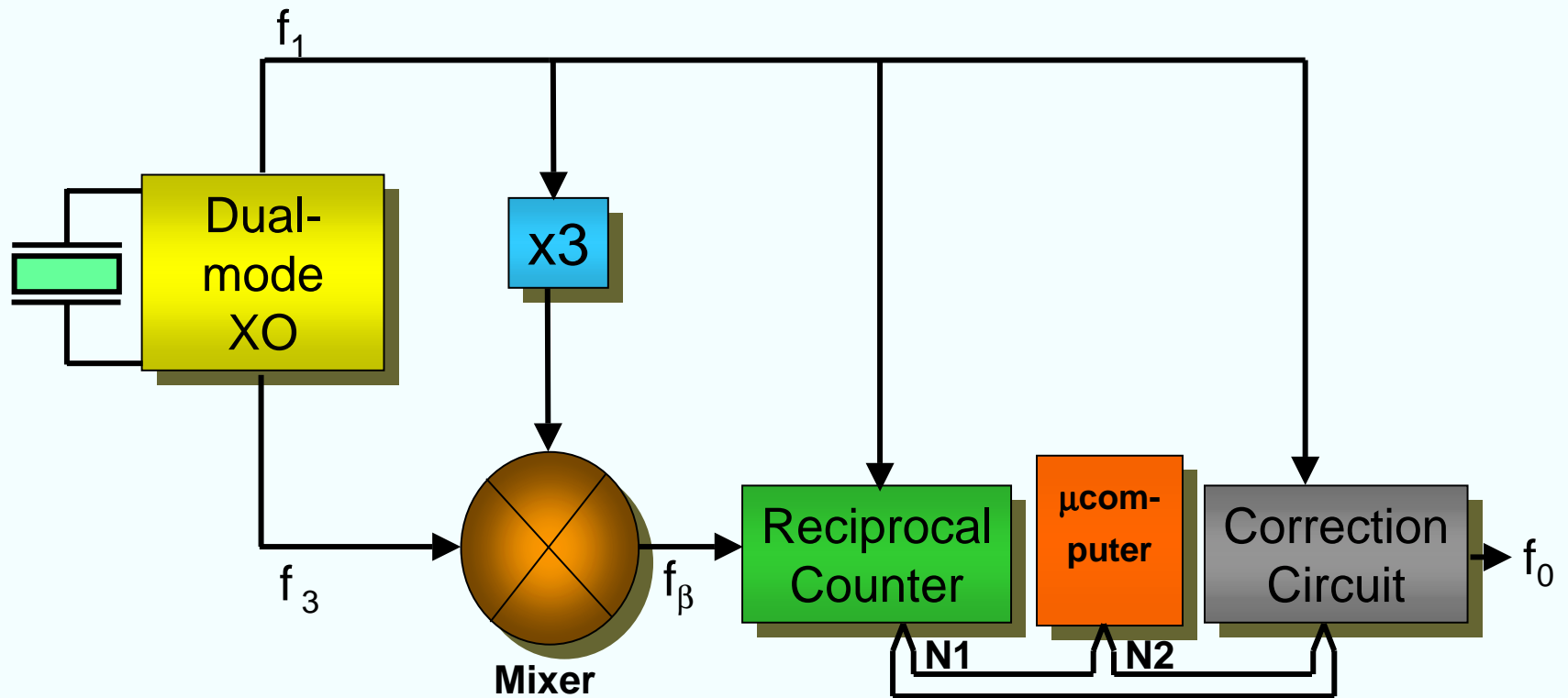

# MCXO Frequency Summing Method

## Block Diagram

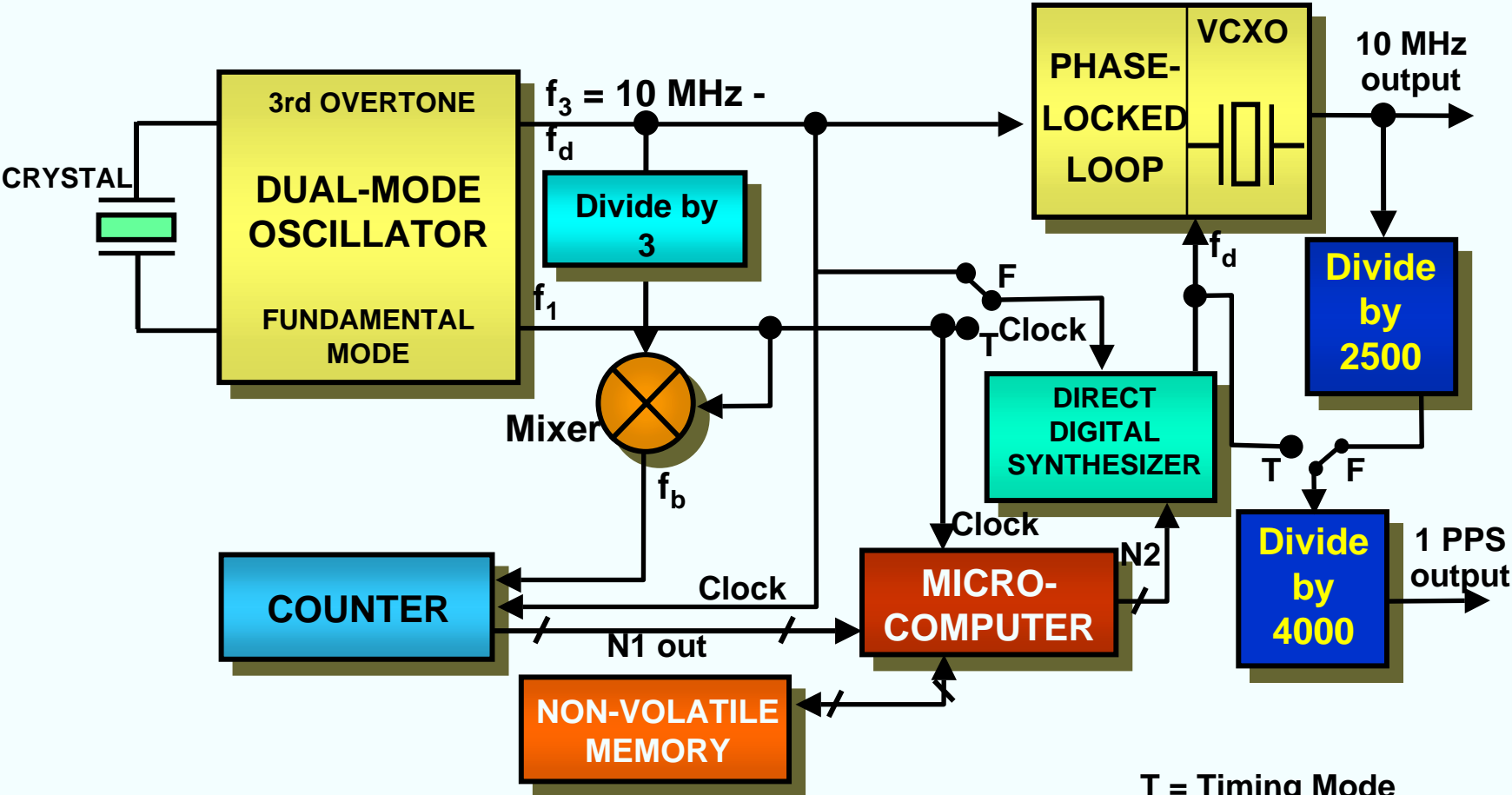

T = Timing Mode  
 F = Frequency Mode

# MCXO - Pulse Deletion Method

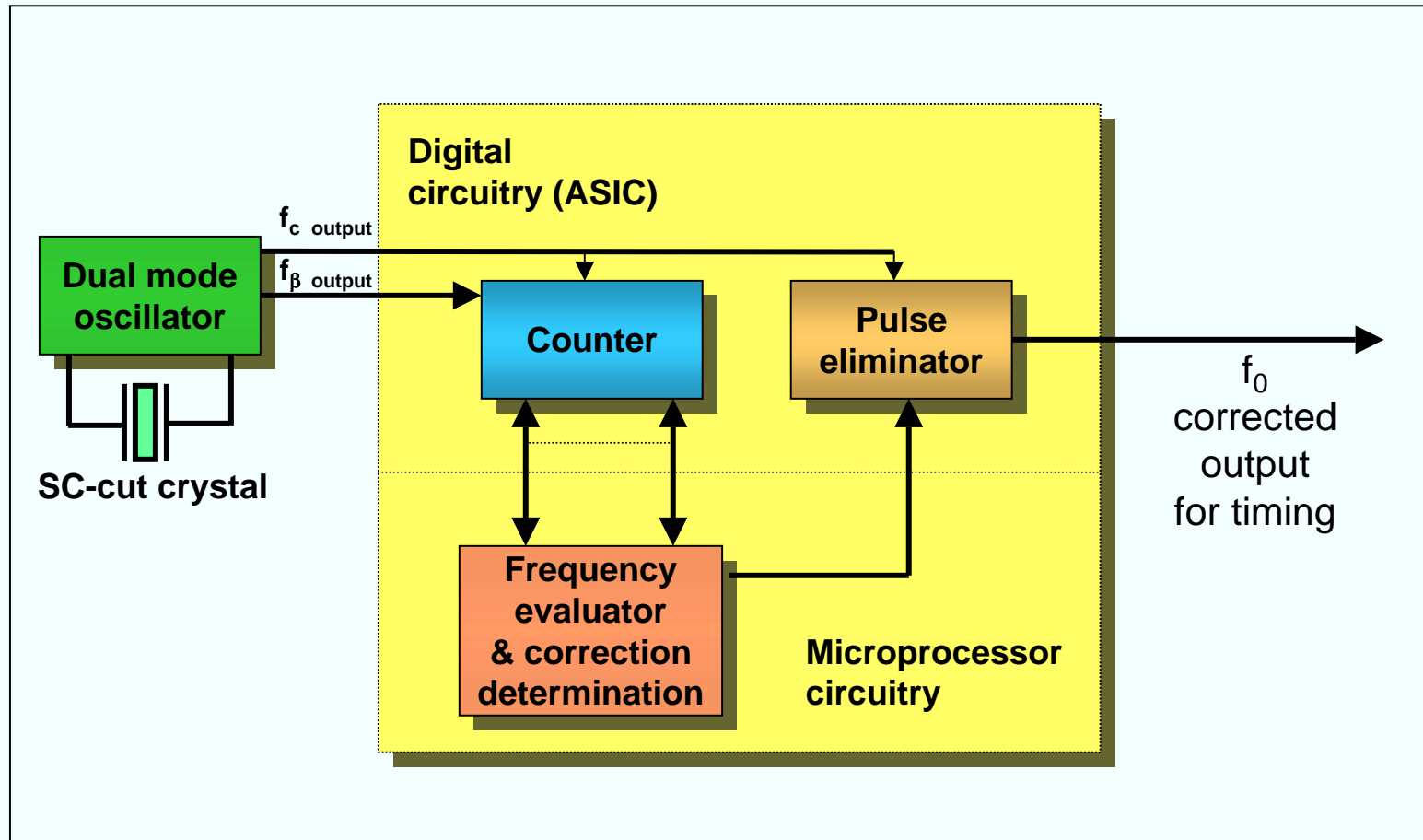

Microcomputer compensated crystal oscillator (MCXO) block diagram - pulse deletion method.

# MCXO - TCXO Resonator Comparison

Parameter	MCXO	TCXO
Cut, overtone	SC-cut, 3rd	AT-cut, fund.
Angle-of-cut tolerance	Loose	Tight
Blank f and plating tolerance	Loose	Tight
Activity dip incidence	Low	Significant
Hysteresis (-55 <sup>0</sup> C to +85 <sup>0</sup> C)	10 <sup>-9</sup> to 10 <sup>-8</sup>	10 <sup>-7</sup> to 10 <sup>-6</sup>
Aging per year	10 <sup>-8</sup> to 10 <sup>-7</sup>	10 <sup>-7</sup> to 10 <sup>-6</sup>



# Opto-Electronic Oscillator (OEO)

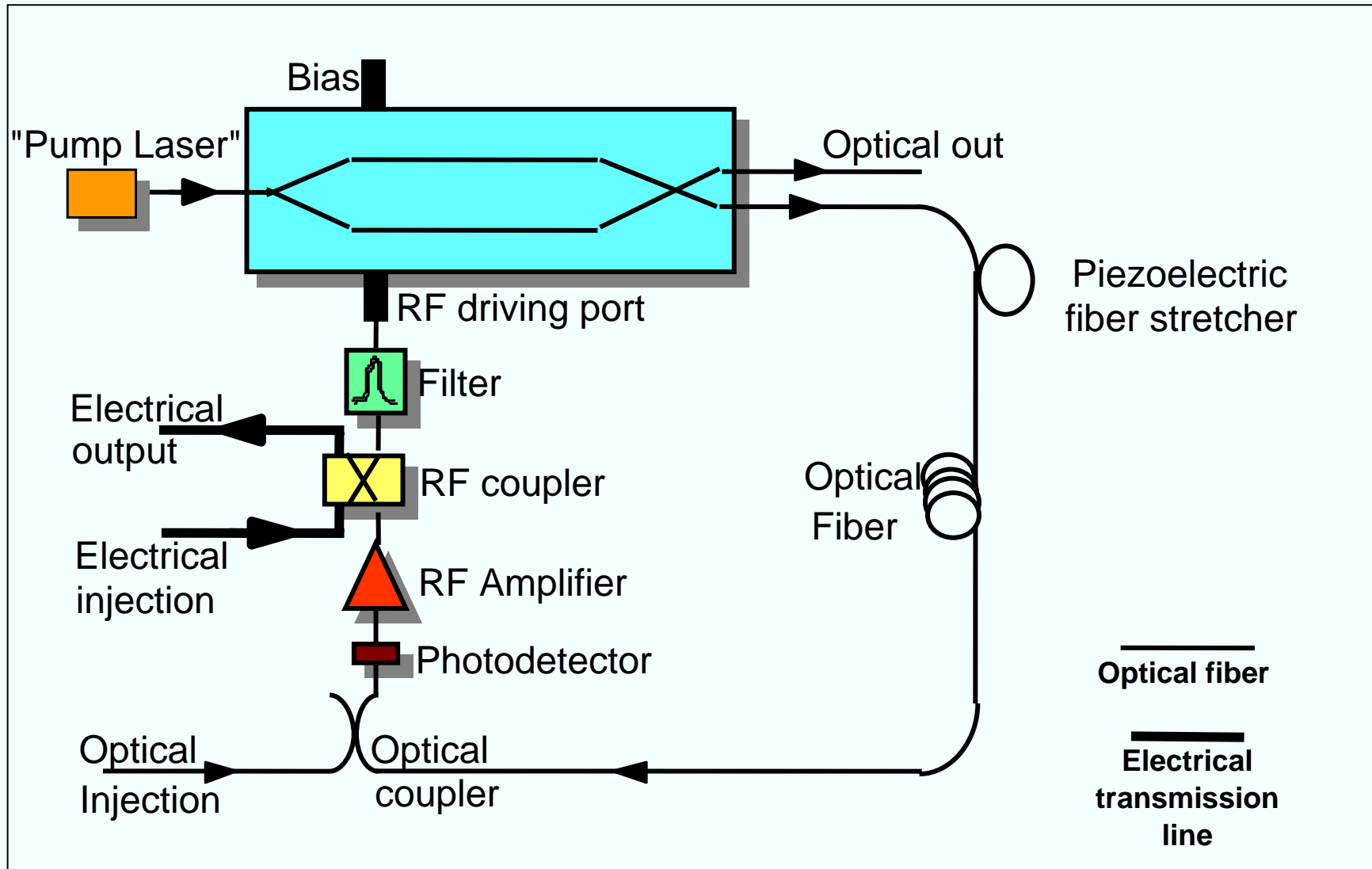

**CHAPTER 3**  
**Quartz Crystal Resonators**

# Why Quartz?

Quartz is the only material known that possesses the following combination of properties:

- Piezoelectric ("pressure-electric"; piezein = to press, in Greek)
- Zero temperature coefficient cuts exist
- Stress compensated cut exists
- Low loss (i.e., high Q)
- Easy to process; low solubility in everything, under "normal" conditions, except the fluoride etchants; hard but not brittle
- Abundant in nature; easy to grow in large quantities, at low cost, and with relatively high purity and perfection. Of the man-grown single crystals, quartz, at ~3,000 tons per year, is second only to silicon in quantity grown (3 to 4 times as much Si is grown annually, as of 1997).

# The Piezoelectric Effect

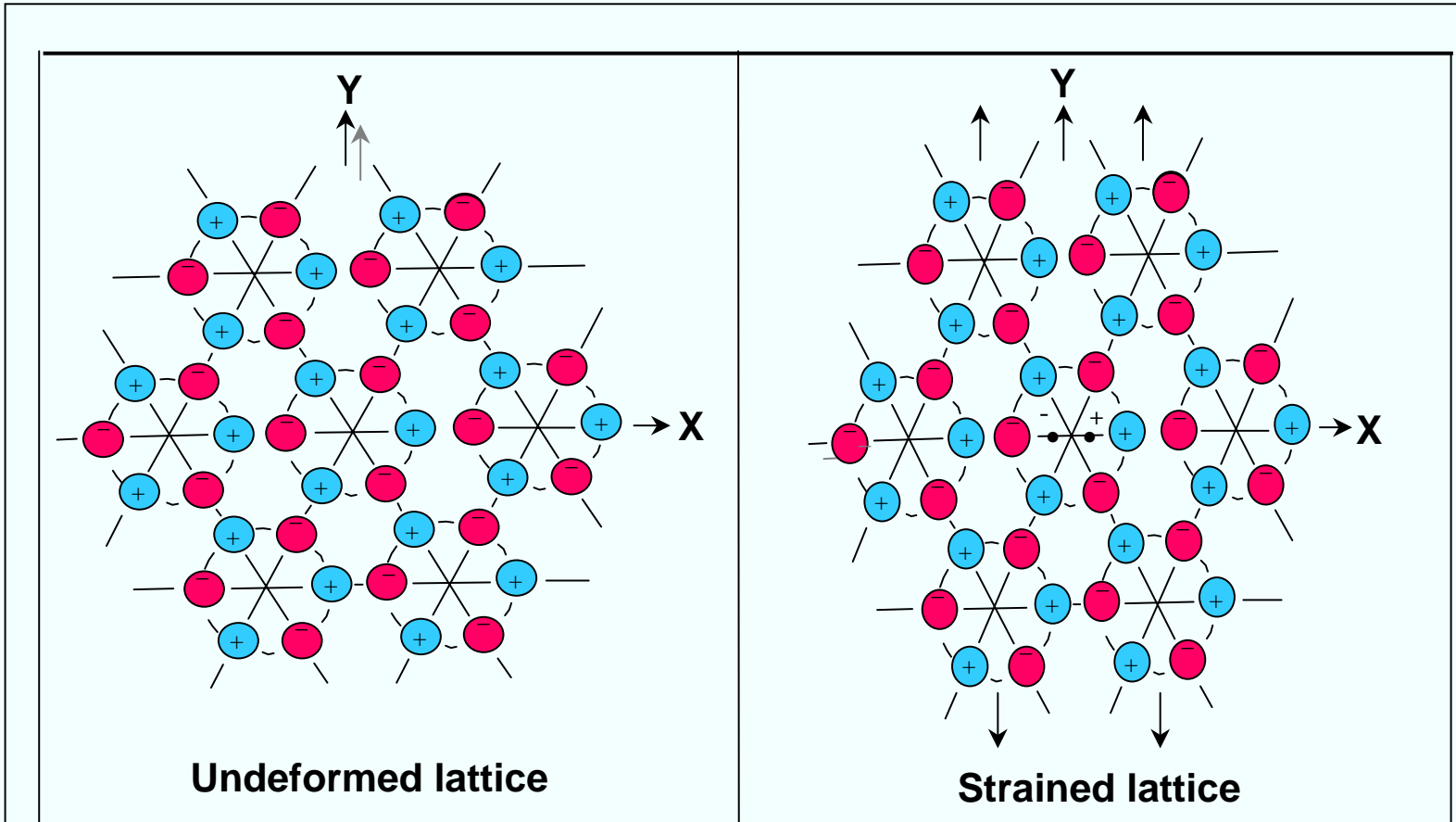

The piezoelectric effect provides a coupling between the mechanical properties of a piezoelectric crystal and an electrical circuit.

# The Piezoelectric Effect in Quartz

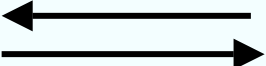
STRAIN		FIELD along:		
		X	Y	Z
 EXTENSIONAL along:	X	√		
	Y	√		
	Z			
 SHEAR about:	X	√		
	Y		√	
	Z		√	

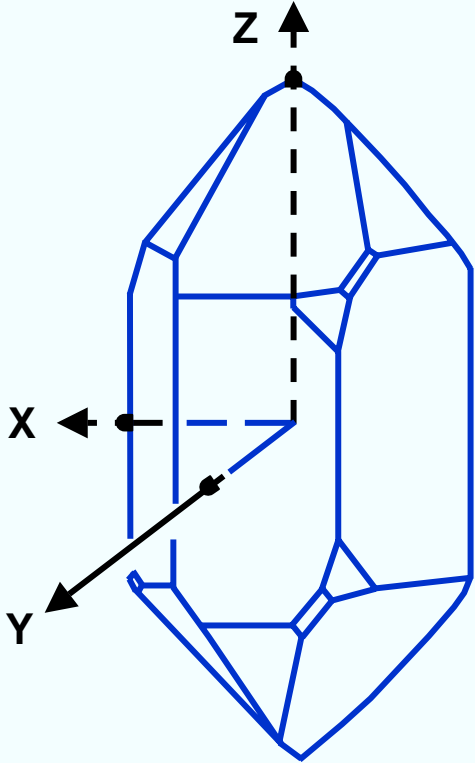

In quartz, the five strain components shown may be generated by an electric field. The modes shown on the next page may be excited by suitably placed and shaped electrodes. The shear strain about the Z-axis produced by the Y-component of the field is used in the rotated Y-cut family, including the AT, BT, and ST-cuts.

# Modes of Motion

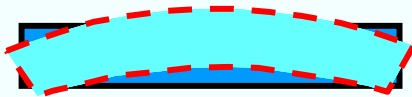

Flexure Mode

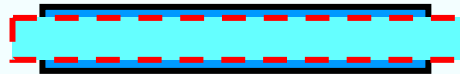

Extensional Mode

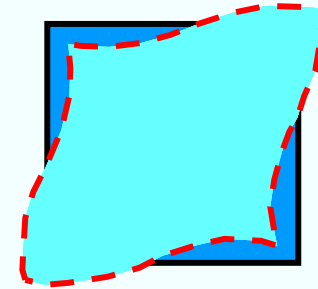

Face Shear Mode

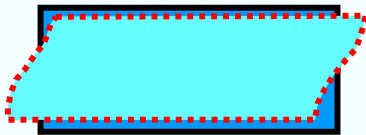

Thickness Shear Mode

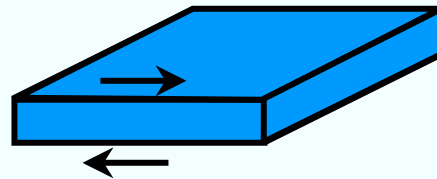

Fundamental Mode Thickness Shear

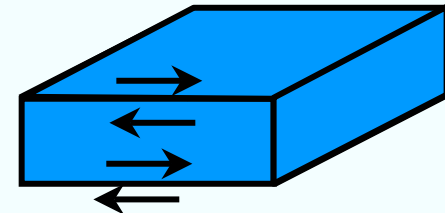

Third Overtone Thickness Shear

# Motion Of A Thickness Shear Crystal

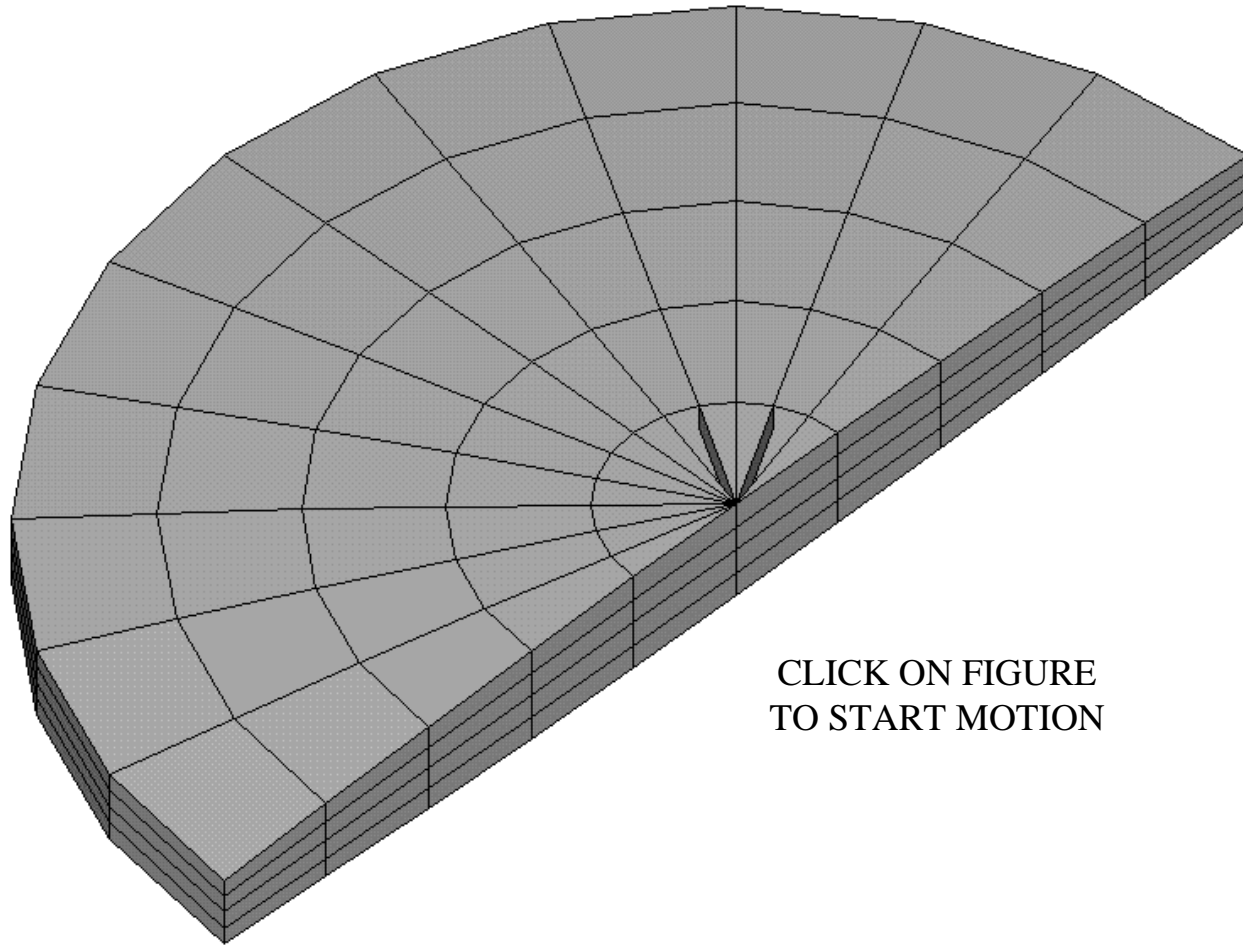

CLICK ON FIGURE  
TO START MOTION

# Resonator Vibration Amplitude Distribution

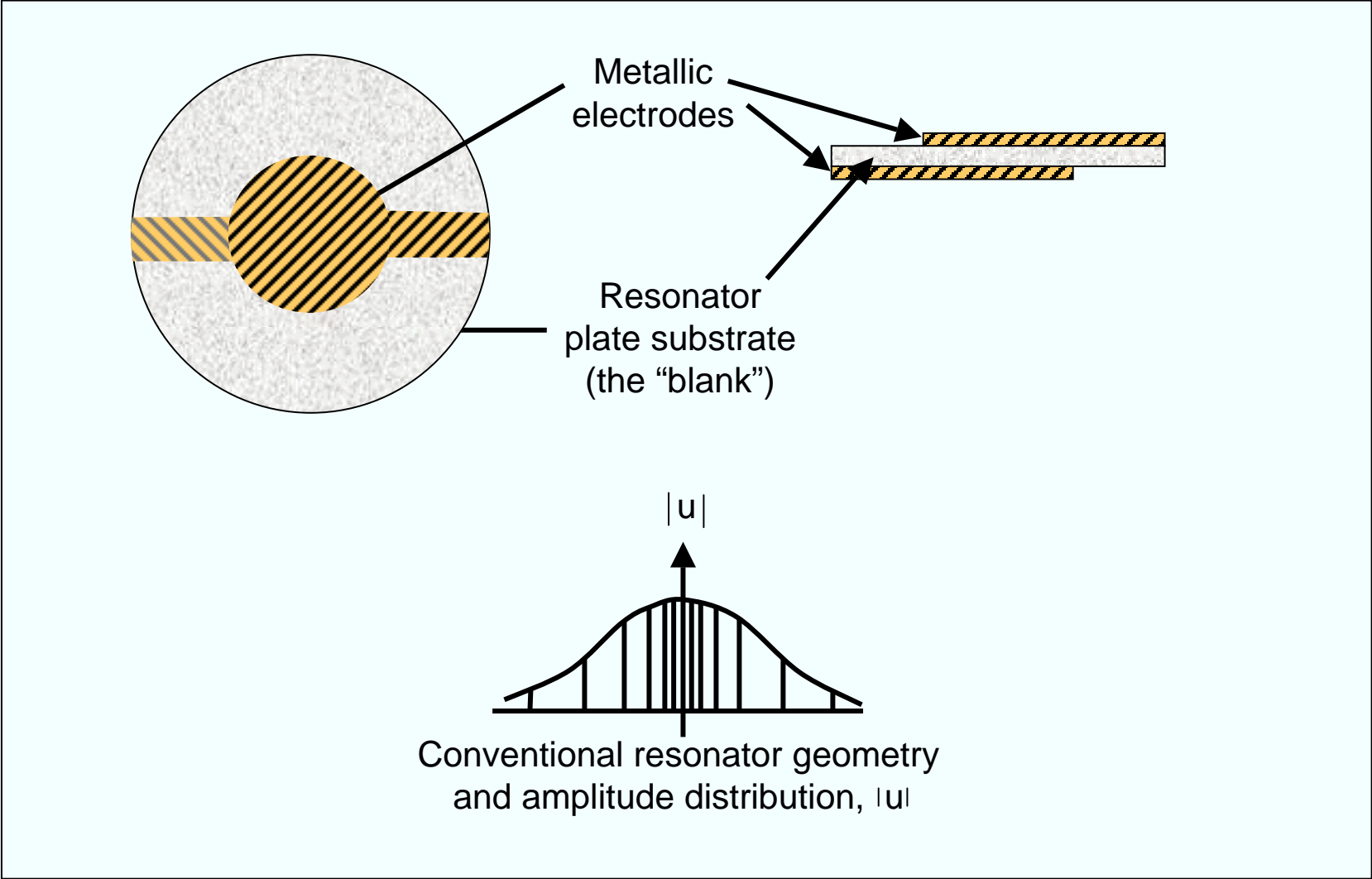



# Resonant Vibrations of a Quartz Plate

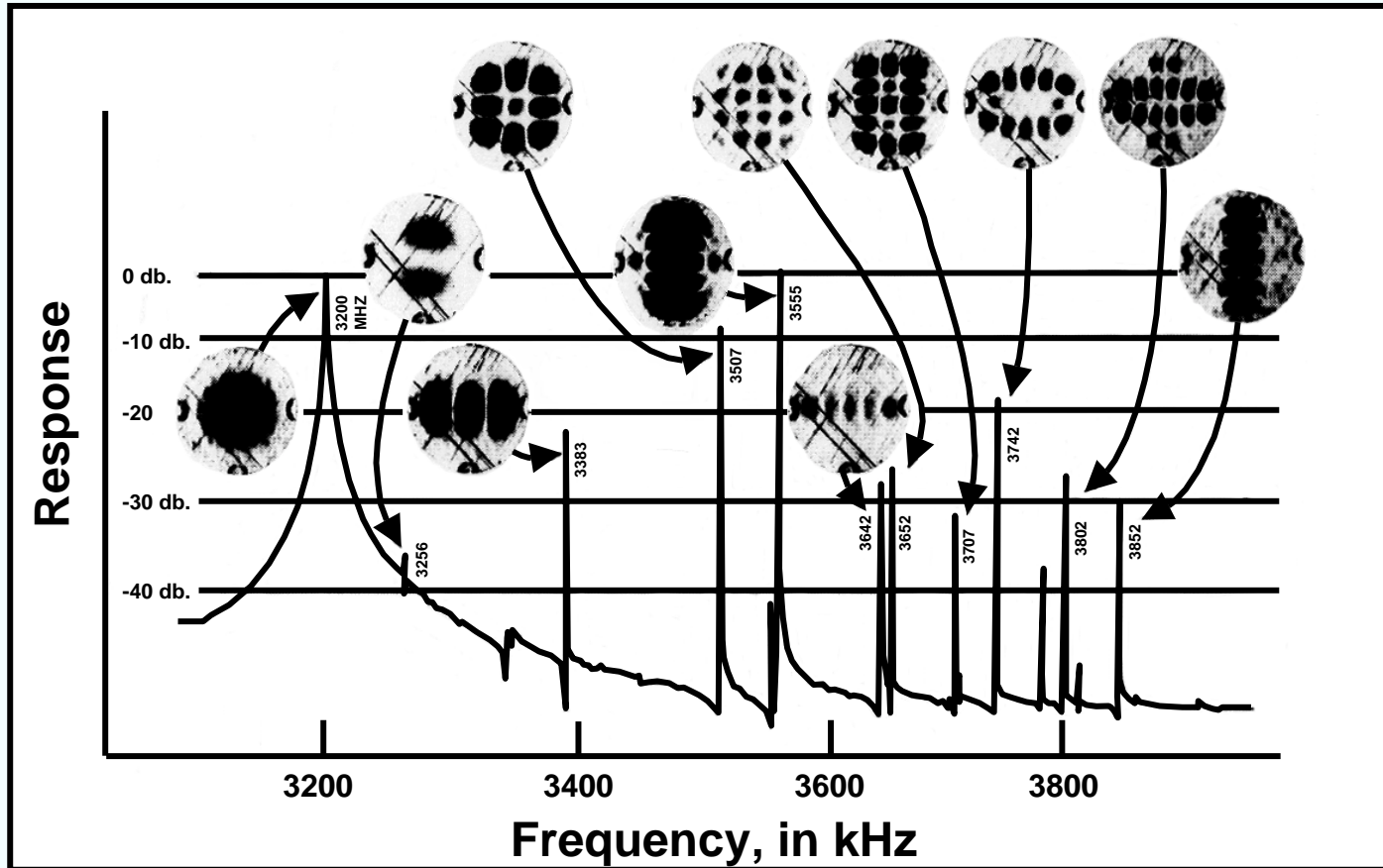

X-ray topographs ( $21\cdot\bar{0}$  plane) of various modes excited during a frequency scan of a fundamental mode, circular, AT-cut resonator. The first peak, at 3.2 MHz, is the main mode; all others are unwanted modes. Dark areas correspond to high amplitudes of displacement.

# Overtone Response of a Quartz Crystal

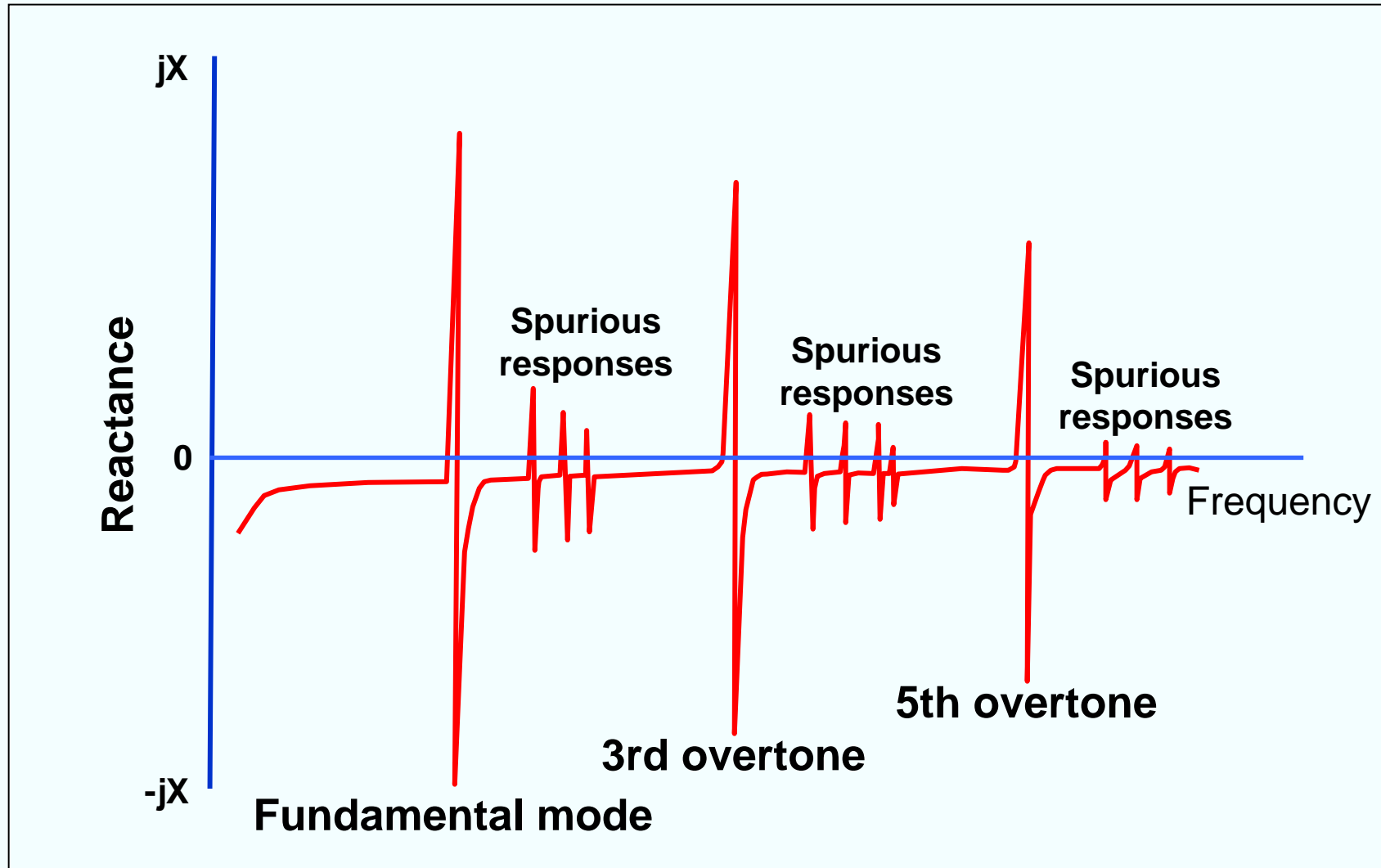

# Unwanted Modes vs. Temperature

(3 MHz rectangular AT-cut resonator, 22 X 27 X 0.552 mm)

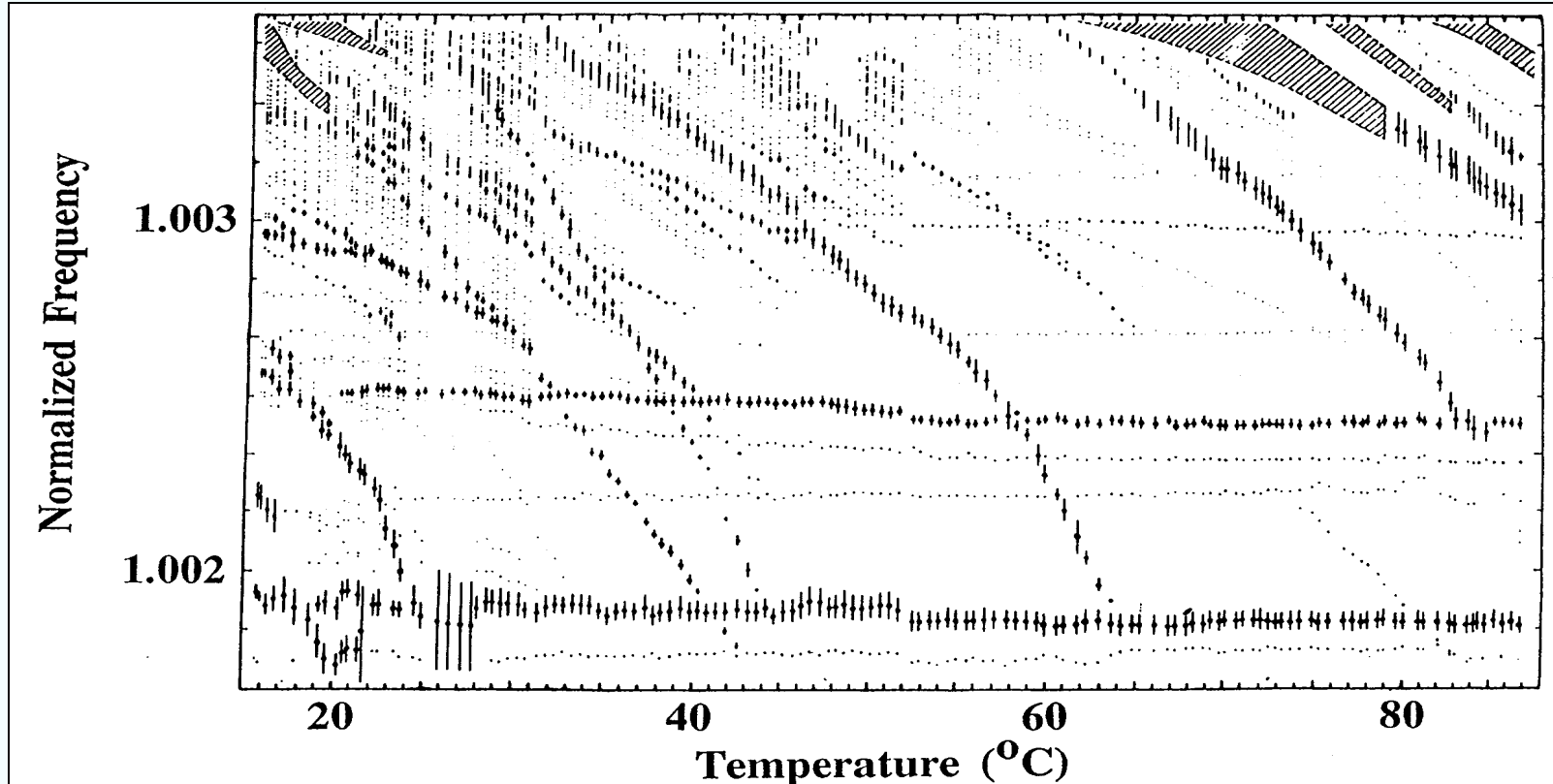

Activity dips occur where the  $f$  vs.  $T$  curves of unwanted modes intersect the  $f$  vs.  $T$  curve of the wanted mode. Such activity dips are highly sensitive to drive level and load reactance.

# Mathematical Description of a Quartz Resonator

- In piezoelectric materials, electrical current and voltage are coupled to elastic displacement and stress:

$$\{T\} = [C] \{S\} - [e] \{E\}$$

$$\{D\} = [e] \{S\} + [\epsilon] \{E\}$$

where  $\{T\}$  = stress tensor,  $[C]$  = elastic stiffness matrix,  $\{S\}$  = strain tensor,  $[e]$  = piezoelectric matrix  
 $\{E\}$  = electric field vector,  $\{D\}$  = electric displacement vector, and  $[\epsilon]$  = is the dielectric matrix

- For a linear piezoelectric material

$$\begin{pmatrix} T_1 \\ T_2 \\ T_3 \\ T_4 \\ T_5 \\ T_6 \\ D_1 \\ D_2 \\ D_3 \end{pmatrix} = \begin{pmatrix} C_{11} & C_{12} & C_{13} & C_{14} & C_{15} & C_{16} & -e_{11} & -e_{21} & -e_{31} \\ C_{21} & C_{22} & C_{23} & C_{24} & C_{25} & C_{26} & -e_{12} & -e_{22} & -e_{32} \\ C_{31} & C_{32} & C_{33} & C_{34} & C_{35} & C_{36} & -e_{13} & -e_{23} & -e_{33} \\ C_{41} & C_{42} & C_{43} & C_{44} & C_{45} & C_{46} & -e_{14} & -e_{24} & -e_{34} \\ C_{51} & C_{52} & C_{53} & C_{54} & C_{55} & C_{56} & -e_{15} & -e_{25} & -e_{35} \\ C_{61} & C_{62} & C_{63} & C_{64} & C_{65} & C_{66} & -e_{16} & -e_{26} & -e_{36} \\ e_{11} & e_{12} & e_{13} & e_{14} & e_{15} & e_{16} & \epsilon_{11} & \epsilon_{12} & \epsilon_{13} \\ e_{21} & e_{22} & e_{23} & e_{24} & e_{25} & e_{26} & \epsilon_{21} & \epsilon_{22} & \epsilon_{23} \\ e_{31} & e_{32} & e_{33} & e_{34} & e_{35} & e_{36} & \epsilon_{31} & \epsilon_{32} & \epsilon_{33} \end{pmatrix} \begin{pmatrix} S_1 \\ S_2 \\ S_3 \\ S_4 \\ S_5 \\ S_6 \\ E_1 \\ E_2 \\ E_3 \end{pmatrix},$$

where

$$\begin{aligned} T_1 &= T_{11}, & S_1 &= S_{11}, \\ T_2 &= T_{22}, & S_2 &= S_{22}, \\ T_3 &= T_{33}, & S_3 &= S_{33}, \\ T_4 &= T_{23}, & S_4 &= 2S_{23}, \\ T_5 &= T_{13}, & S_5 &= 2S_{13}, \\ T_6 &= T_{12}, & S_6 &= 2S_{12}, \end{aligned}$$

- Elasto-electric matrix for quartz

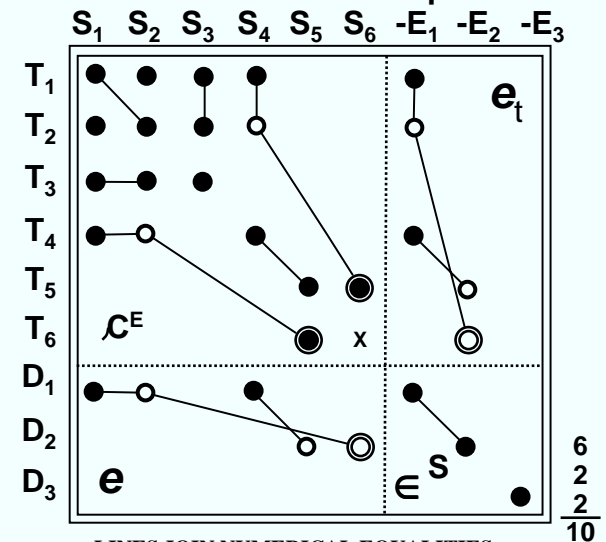

LINES JOIN NUMERICAL EQUALITIES EXCEPT FOR COMPLETE RECIPROACITY ACROSS PRINCIPAL DIAGONAL  
 ○ INDICATES NEGATIVE OF ●  
 ●○ INDICATES TWICE THE NUMERICAL EQUALITIES  
 X INDICATES 1/2 (c<sub>11</sub> - c<sub>12</sub>)

# Mathematical Description - Continued

- Number of independent non-zero constants depend on crystal symmetry. For quartz (trigonal, class 32), there are 10 independent linear constants - 6 elastic, 2 piezoelectric and 2 dielectric. "Constants" depend on temperature, stress, coordinate system, etc.

- To describe the behavior of a resonator, the differential equations for Newton's law of motion for a continuum, and for Maxwell's equation\* must be solved, with the proper electrical and mechanical boundary conditions at the plate surfaces.

$$(F = ma \Rightarrow \frac{\partial T_{ij}}{\partial x_j} = \rho \ddot{u}_i; \quad \nabla \cdot \bar{D} = 0 \Rightarrow \frac{\partial D_i}{\partial x_i} = 0,$$

$$E_i = -\frac{\partial \phi}{\partial x_i}; \quad S_{ij} = \frac{1}{2} \left( \frac{\partial u_i}{\partial x_j} + \frac{\partial u_j}{\partial x_i} \right); \text{ etc.})$$

- Equations are very "messy" - they have never been solved in closed form for physically realizable three-dimensional resonators. Nearly all theoretical work has used approximations.
- Some of the most important resonator phenomena (e.g., acceleration sensitivity) are due to nonlinear effects. Quartz has numerous higher order constants, e.g., 14 third-order and 23 fourth-order elastic constants, as well as 16 third-order piezoelectric coefficients are known; nonlinear equations are extremely messy.

---

\* Magnetic field effects are generally negligible; quartz is diamagnetic, however, magnetic fields can affect the mounting structure and electrodes.

# Infinite Plate Thickness Shear Resonator

$$f_n = \frac{n}{2h} \sqrt{\frac{c_{ij}}{\rho}}, \quad n = 1, 3, 5 \dots$$

Where  $f_n$  = resonant frequency of n-th harmonic

$h$  = plate thickness

$\rho$  = density

$c_{ij}$  = elastic modulus associated with the elastic wave  
being propagated

$$T_f = \frac{d(\log f_n)}{dT} = \frac{1}{f_n} \frac{df_n}{dT} = \frac{-1}{h} \frac{dh}{dT} - \frac{1}{2\rho} \frac{d\rho}{dT} + \frac{1}{2c_{ij}} \frac{dc_{ij}}{dT}$$

where  $T_f$  is the linear temperature coefficient of frequency. The temperature coefficient of  $c_{ij}$  is negative for most materials (i.e., “springs” become “softer” as  $T$  increases). The coefficients for quartz can be +, - or zero (see next page).

# Quartz is Highly Anisotropic

- The properties of quartz vary greatly with crystallographic direction. For example, when a quartz sphere is etched deeply in HF, the sphere takes on a triangular shape when viewed along the Z-axis, and a lenticular shape when viewed along the Y-axis. The etching rate is more than 100 times faster along the fastest etching rate direction (the Z-direction) than along the slowest direction (the slow-X-direction).
- The thermal expansion coefficient is  $7.8 \times 10^{-6}/^{\circ}\text{C}$  along the Z-direction, and  $14.3 \times 10^{-6}/^{\circ}\text{C}$  perpendicular to the Z-direction; the temperature coefficient of density is, therefore,  $-36.4 \times 10^{-6}/^{\circ}\text{C}$ .
- The temperature coefficients of the elastic constants range from  $-3300 \times 10^{-6}/^{\circ}\text{C}$  (for  $C_{12}$ ) to  $+164 \times 10^{-6}/^{\circ}\text{C}$  (for  $C_{66}$ ).
- For the proper angles of cut, the sum of the first two terms in  $T_f$  on the previous page is cancelled by the third term, i.e., temperature compensated cuts exist in quartz. (See next page.)

# Zero Temperature Coefficient Quartz Cuts

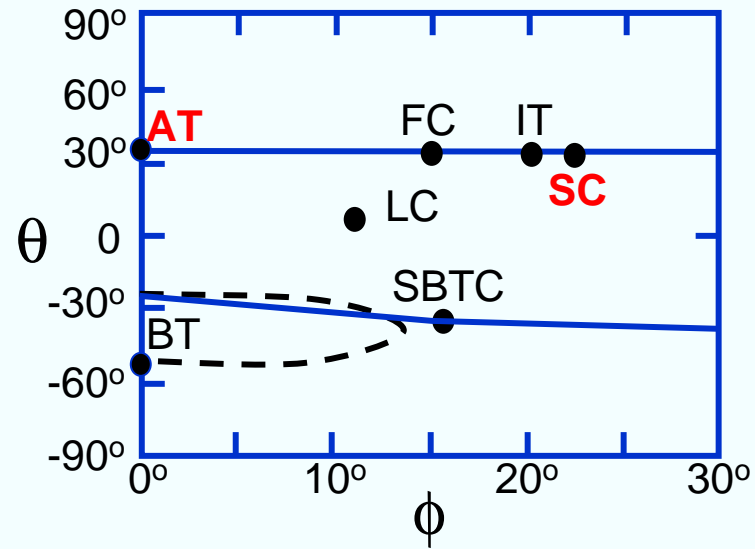
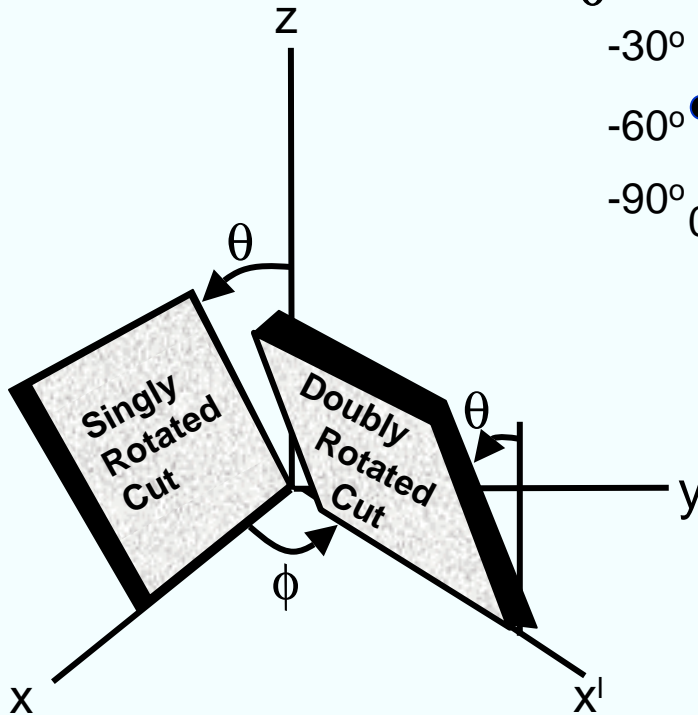

The AT, FC, IT, SC, BT, and SBTC-cuts are some of the cuts on the locus of zero temperature coefficient cuts. The LC is a "linear coefficient" cut that has been used in a quartz thermometer.

Y-cut:  $\approx +90 \text{ ppm}/^\circ\text{C}$   
(thickness-shear mode)

X-cut:  $\approx -20 \text{ ppm}/^\circ\text{C}$   
(extensional mode)



# Comparison of SC and AT-cuts

- **Advantages of the SC-cut**
  - Thermal transient compensated (allows faster warmup OCXO)
  - Static and dynamic  $f$  vs.  $T$  allow higher stability OCXO and MCXO
  - Better  $f$  vs.  $T$  repeatability allows higher stability OCXO and MCXO
  - Far fewer activity dips
  - Lower drive level sensitivity
  - Planar stress compensated; lower  $\Delta f$  due to edge forces and bending
  - Lower sensitivity to radiation
  - Higher capacitance ratio (less  $\Delta f$  for oscillator reactance changes)
  - Higher  $Q$  for fundamental mode resonators of similar geometry
  - Less sensitive to plate geometry - can use wide range of contours
- **Disadvantage of the SC-cut** : More difficult to manufacture for OCXO (but is easier to manufacture for MCXO than is an AT-cut for precision TCXO)
- **Other Significant Differences**
  - B-mode is excited in the SC-cut, although not necessarily in LFR's
  - The SC-cut is sensitive to electric fields (which can be used for compensation)

# Mode Spectrograph of an SC-cut

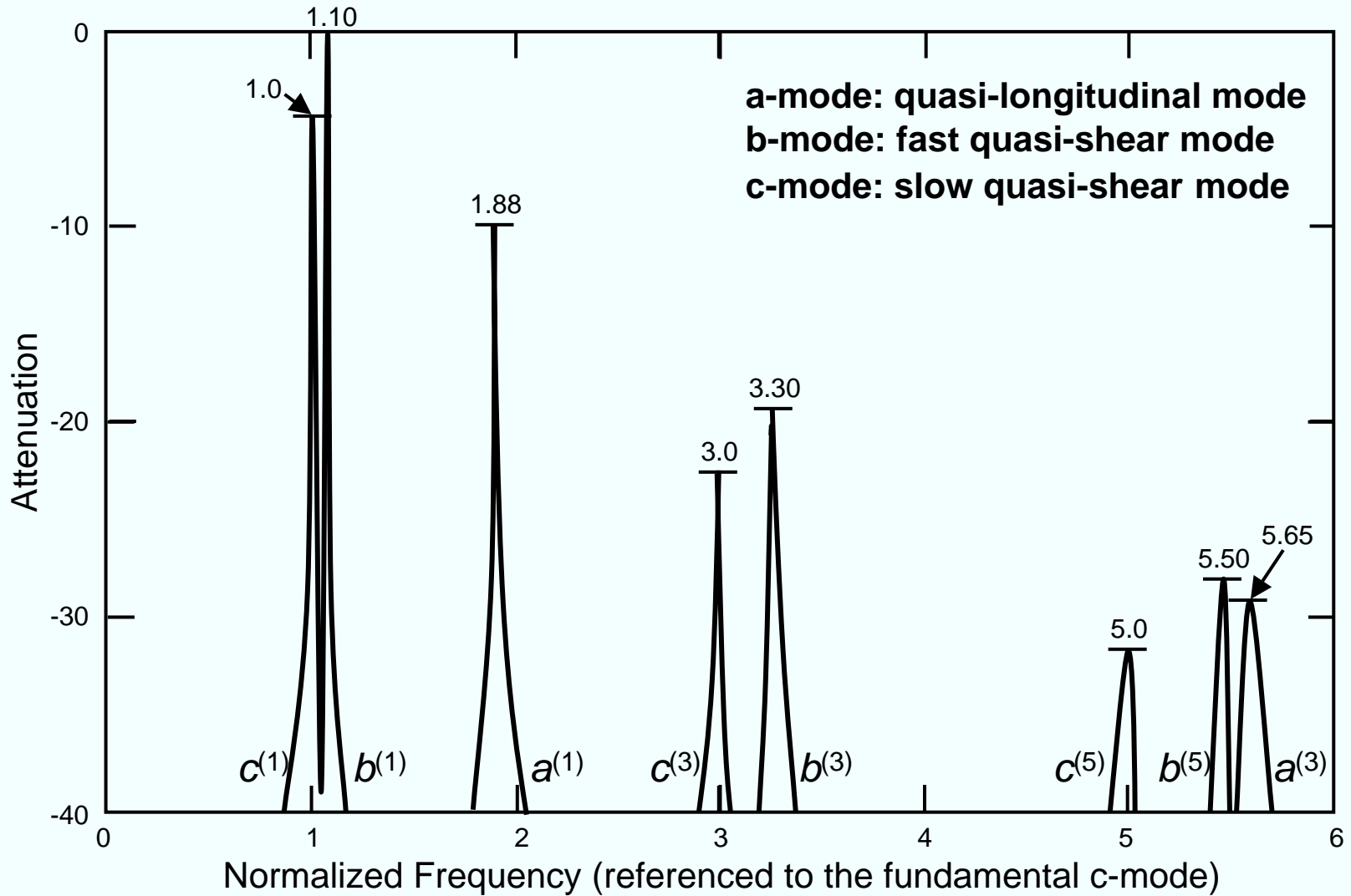

# SC- cut f vs. T for b-mode and c-mode

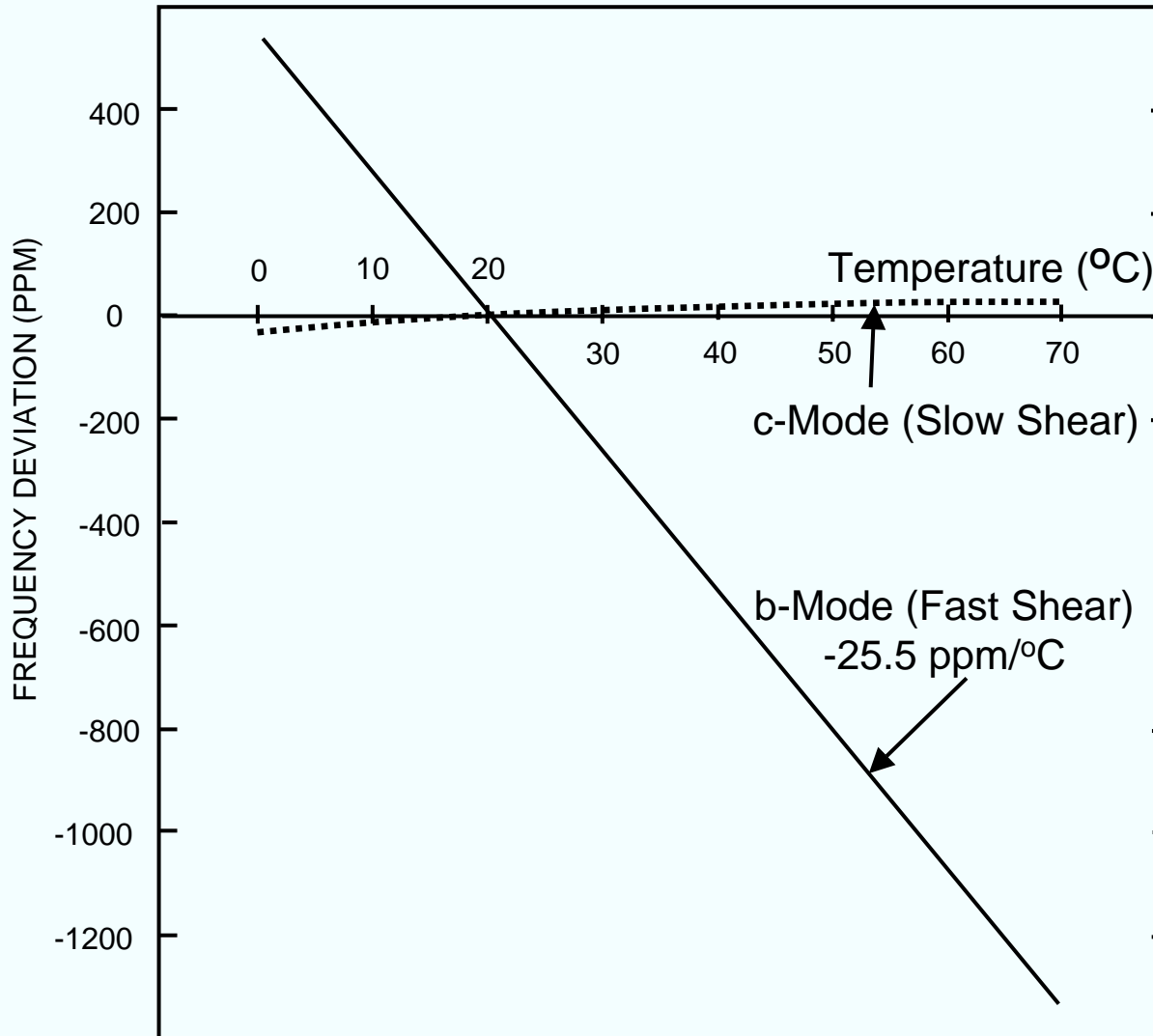

# B and C Modes Of A Thickness Shear Crystal

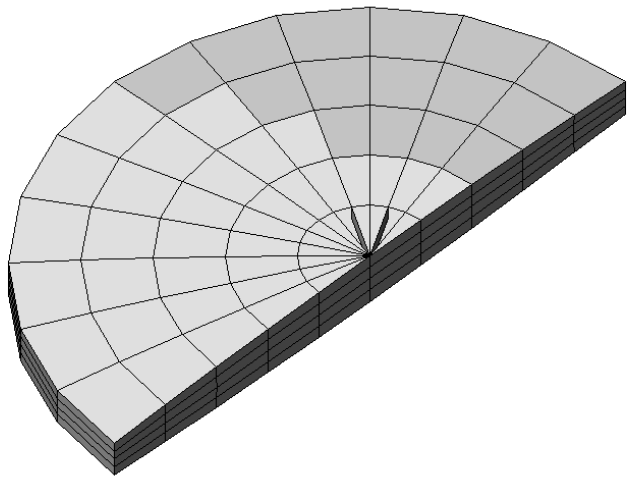

C MODE

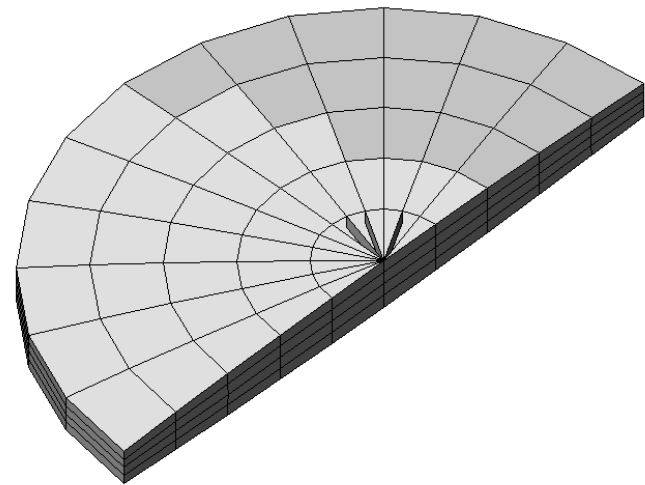

B MODE

CLICK ON FIGURES  
TO START MOTION

# Singly Rotated and Doubly Rotated Cuts' Vibrational Displacements

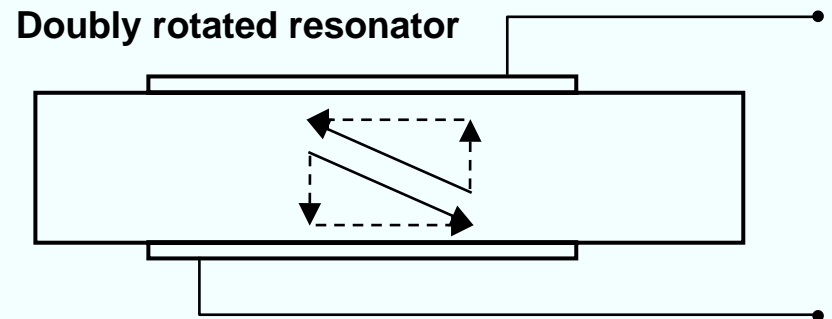
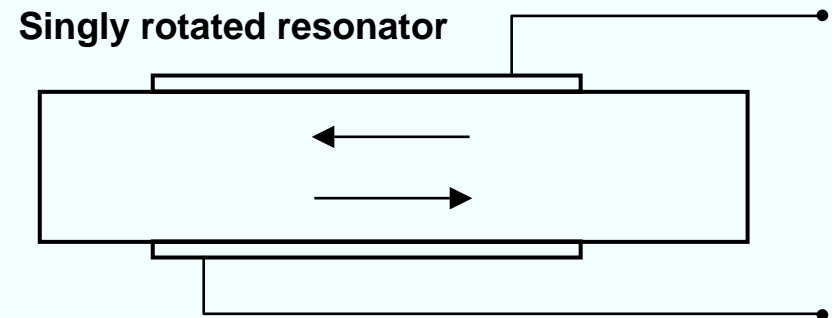
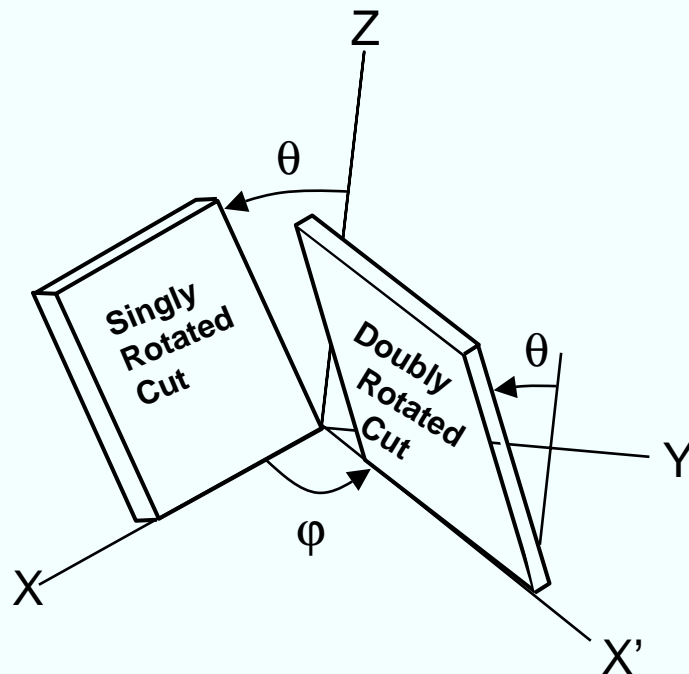

# Resonator Packaging

## Two-point Mount Package

## Three- and Four-point Mount Package

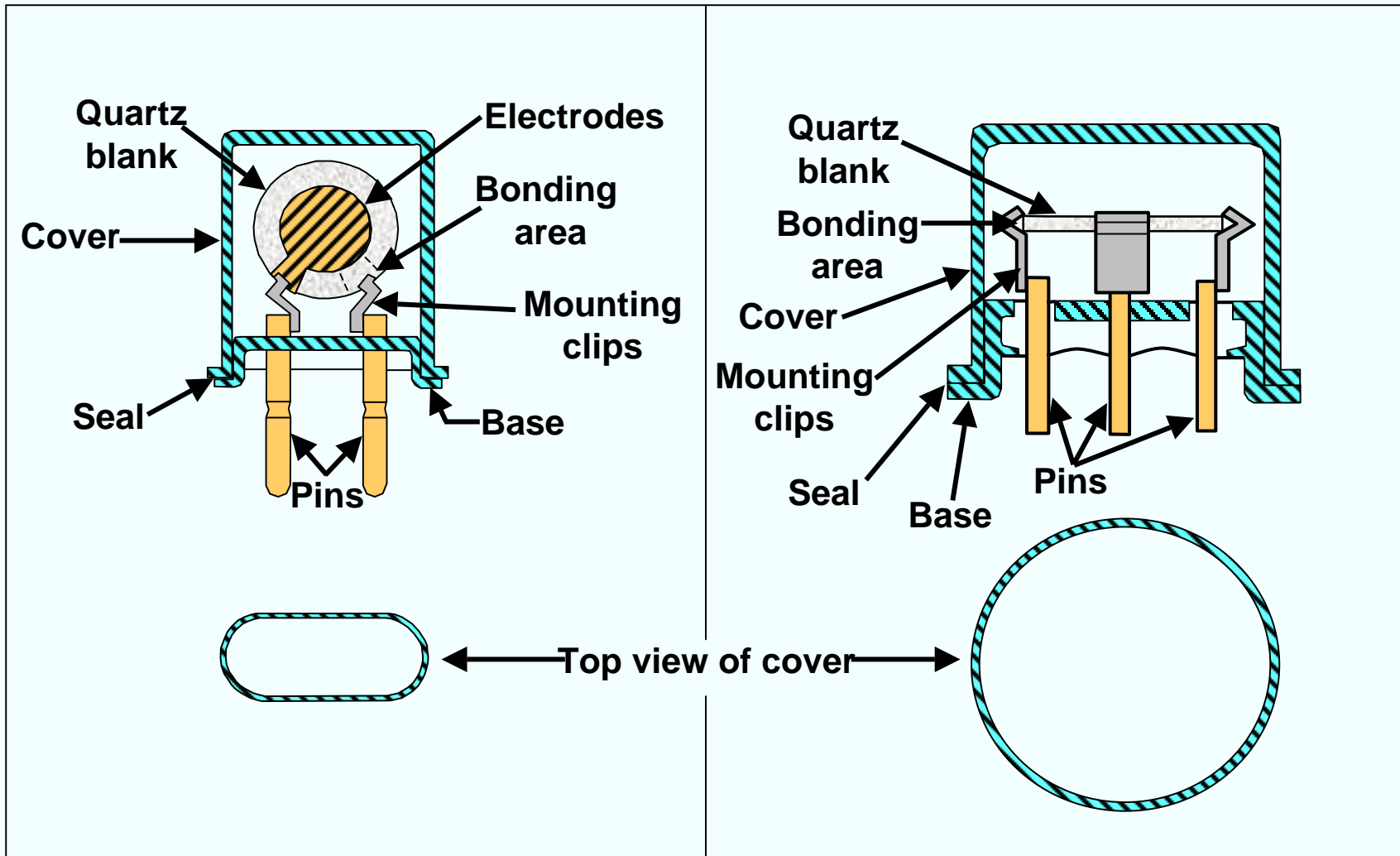

# Equivalent Circuits

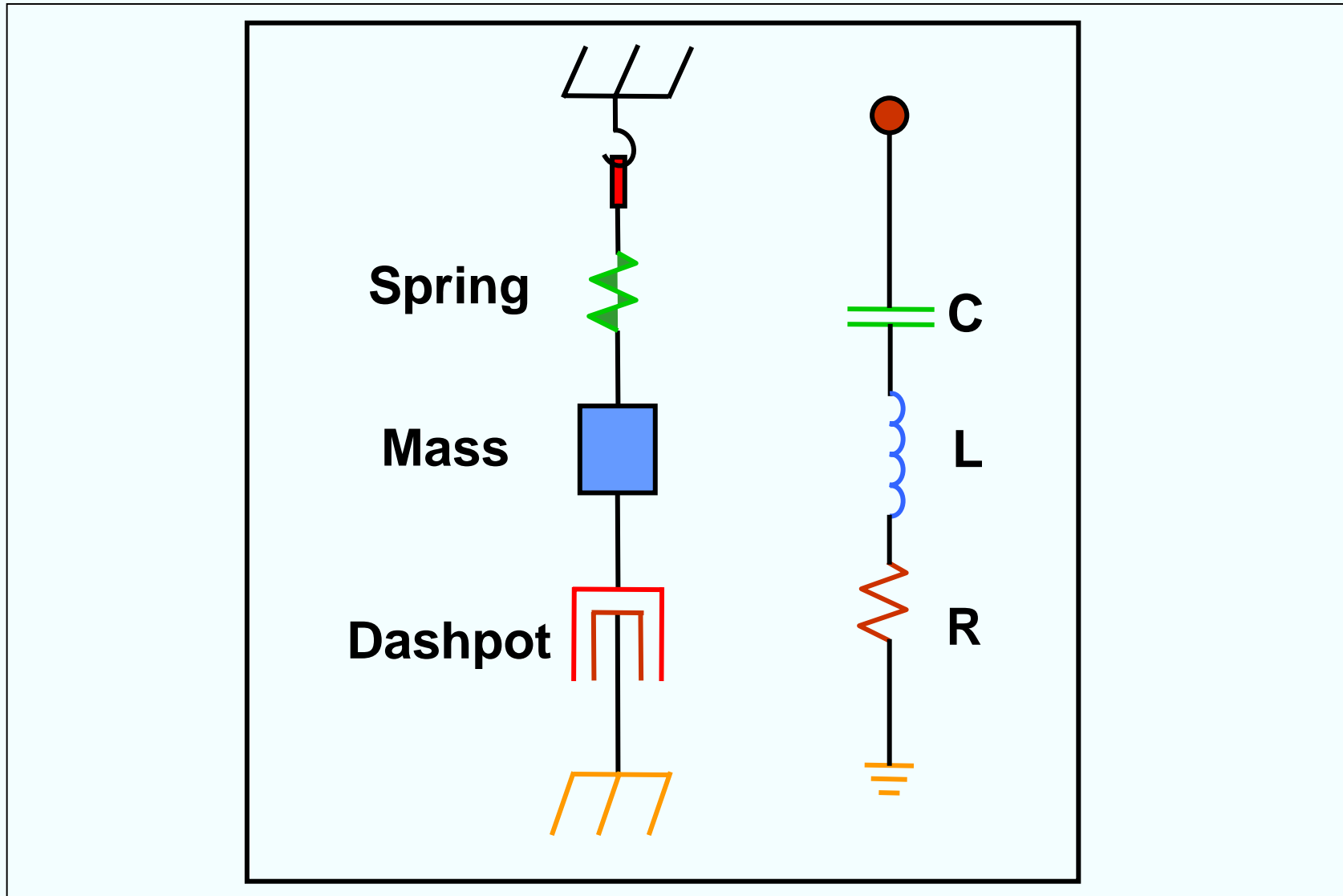

# Equivalent Circuit of a Resonator

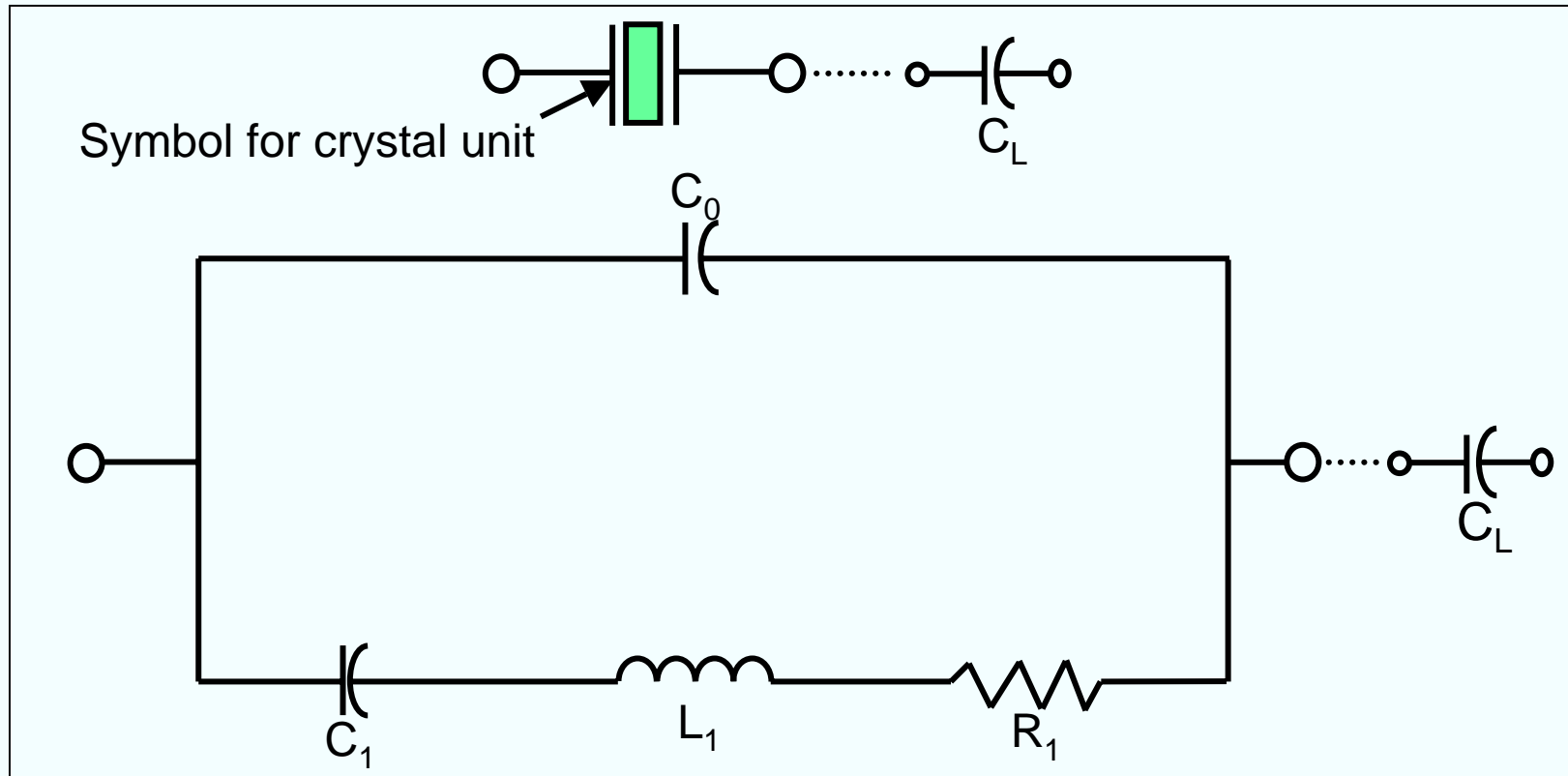

$$\frac{\Delta f}{f_s} \approx \frac{C_1}{2(C_0 + C_L)} \rightarrow \begin{cases} 1. \text{ Voltage control (VCXO)} \\ 2. \text{ Temperature compensation (TCXO)} \end{cases}$$



# Crystal Oscillator $f$ vs. $T$ Compensation

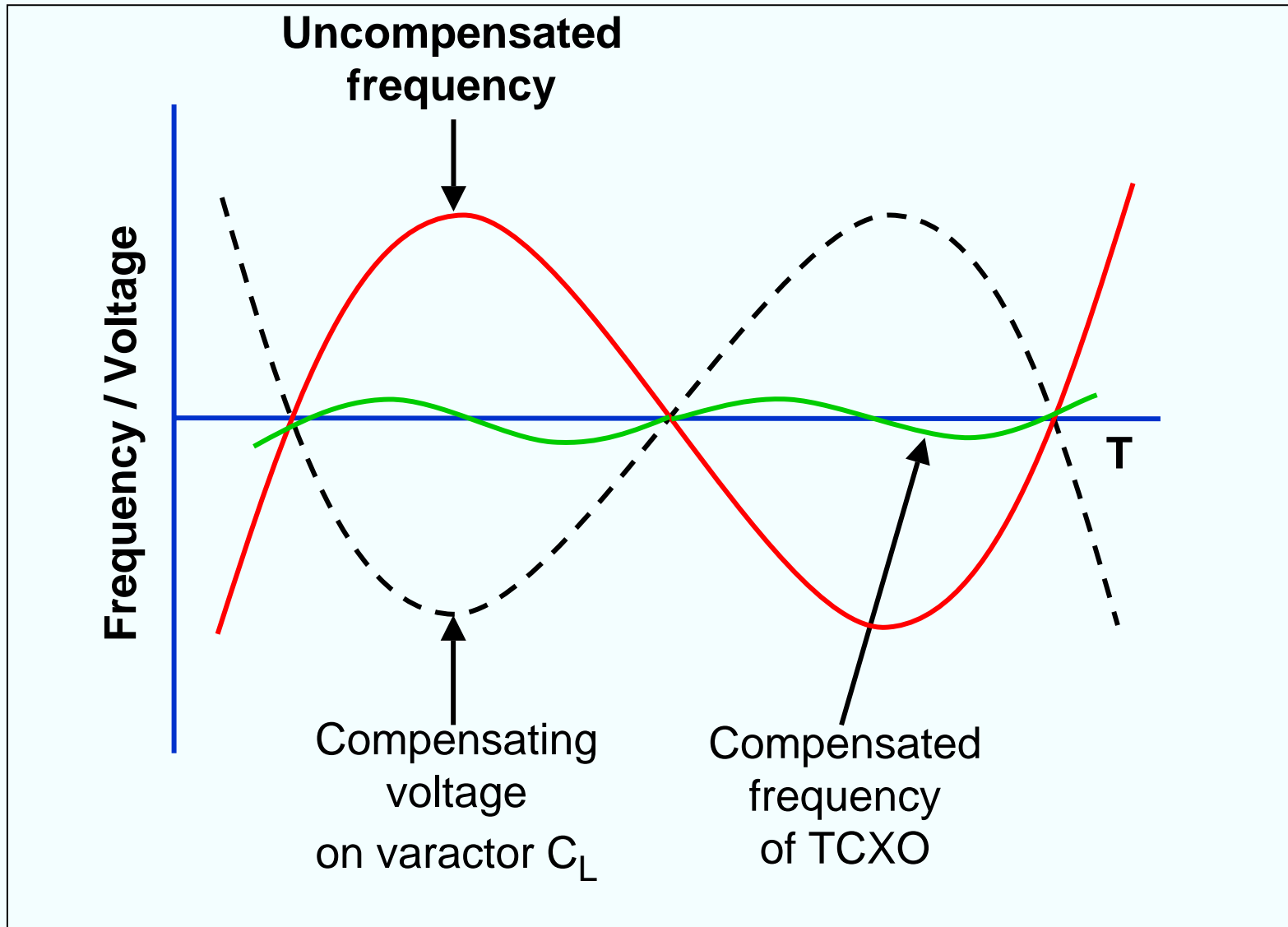

# Resonator Reactance vs. Frequency

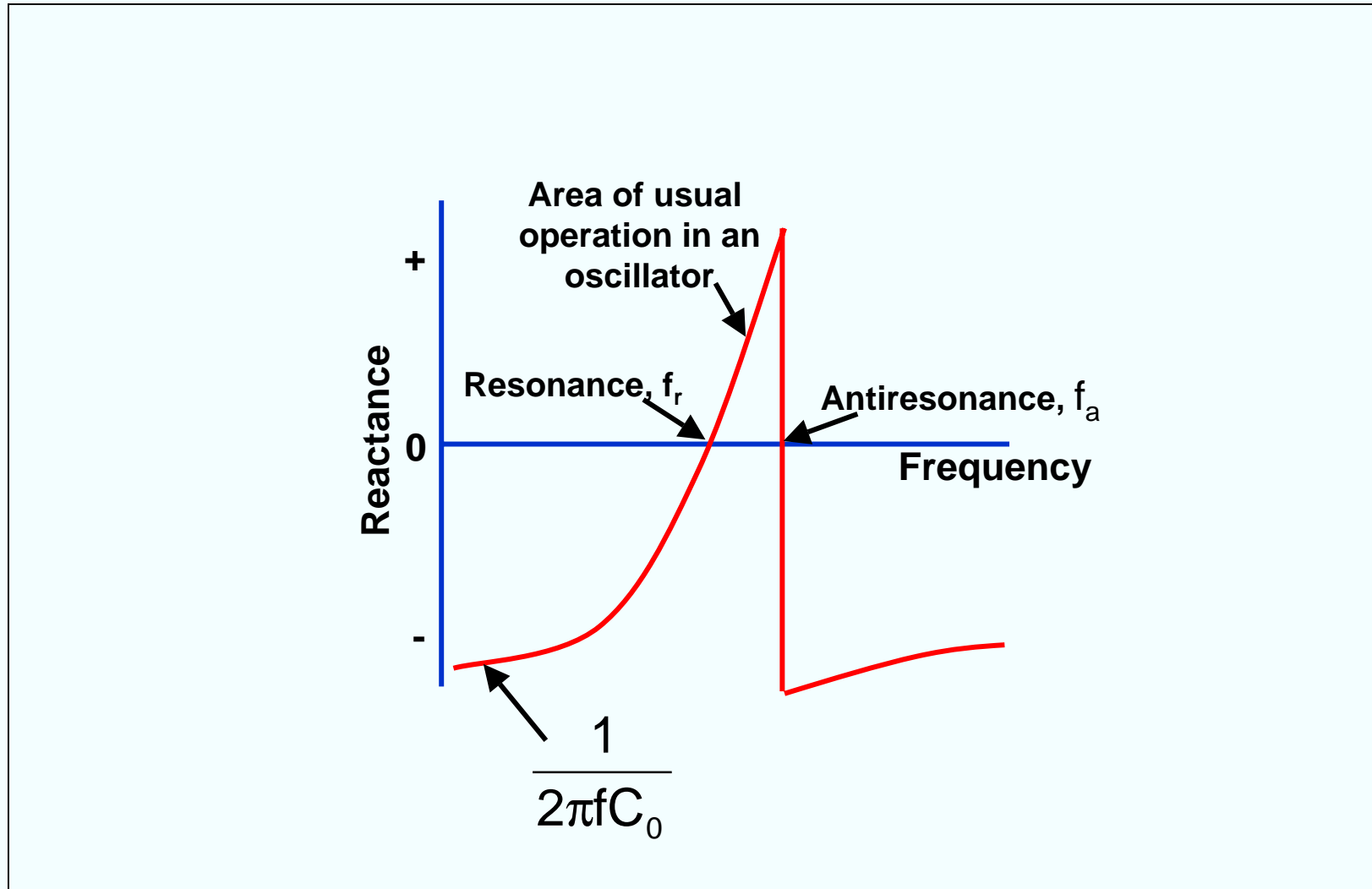

# Equivalent Circuit Parameter Relationships

$$C_0 \cong \epsilon \frac{A}{t}$$

$$r \equiv \frac{C_0}{C_1}$$

$$f_s = \frac{1}{2\pi} \sqrt{\frac{1}{L_1 C_1}}$$

$$f_a - f_s \cong \frac{f_s}{2r}$$

$$Q = \frac{1}{2\pi f_s R_1 C_1}$$

$$\phi = \frac{\omega L_1 - \frac{1}{\omega C_1}}{R_1}$$

$$\tau_1 = R_1 C_1 \cong 10^{-14} \text{ s}$$

$$\frac{d\phi}{df} \cong \frac{360 Q}{\pi f_s}$$

$$C_{1n} \approx \frac{r' C_{11}}{n^3}$$

$$L_{1n} \approx \frac{n^3 L_{11}}{r'^3}$$

$$R_{1n} \approx \frac{n^3 R_{11}}{r'}$$

$$2r = \left( \frac{\pi n}{2k} \right)^2$$

n:	Overtone number
$C_0$ :	Static capacitance
$C_1$ :	Motional capacitance
$C_{1n}$ :	$C_1$ of n-th overtone
$L_1$ :	Motional inductance
$L_{1n}$ :	$L_1$ of n-th overtone
$R_1$ :	Motional resistance
$R_{1n}$ :	$R_1$ of n-th overtone
$\epsilon$ :	Dielectric permittivity of quartz $\approx 40 \times 10^{-13}$ pF/mm (average)
A:	Electrode area
t:	Plate thickness
r:	Capacitance ratio
$r'$ :	$f_1/f_n$
$f_s$ :	Series resonance frequency $\approx f_R$
$f_a$ :	Antiresonance frequency
Q:	Quality factor
$\tau_1$ :	Motional time constant
$\omega$ :	Angular frequency = $2\pi f$
$\phi$ :	Phase angle of the impedance
k:	Piezoelectric coupling factor =8.8% for AT-cut, 4.99% for SC

# What is Q and Why is it Important?

$$Q \equiv 2 \pi \frac{\text{Energy stored during a cycle}}{\text{Energy dissipated per cycle}}$$

Q is proportional to the decay-time, and is inversely proportional to the linewidth of resonance (see next page).

- The higher the Q, the higher the frequency stability and accuracy **capability** of a resonator (i.e., high Q is a necessary but not a sufficient condition). If, e.g.,  $Q = 10^6$ , then  $10^{-10}$  accuracy requires ability to determine center of resonance curve to 0.01% of the linewidth, and stability (for some averaging time) of  $10^{-12}$  requires ability to stay near peak of resonance curve to  $10^{-6}$  of linewidth.
- Phase noise close to the carrier has an especially strong dependence on Q ( $L(f) \propto 1/Q^4$ ).

# Decay Time, Linewidth, and Q

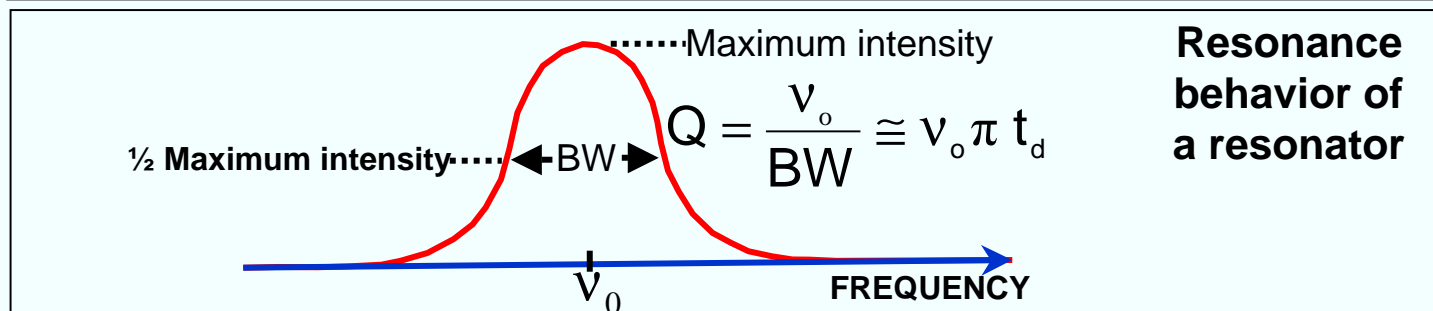
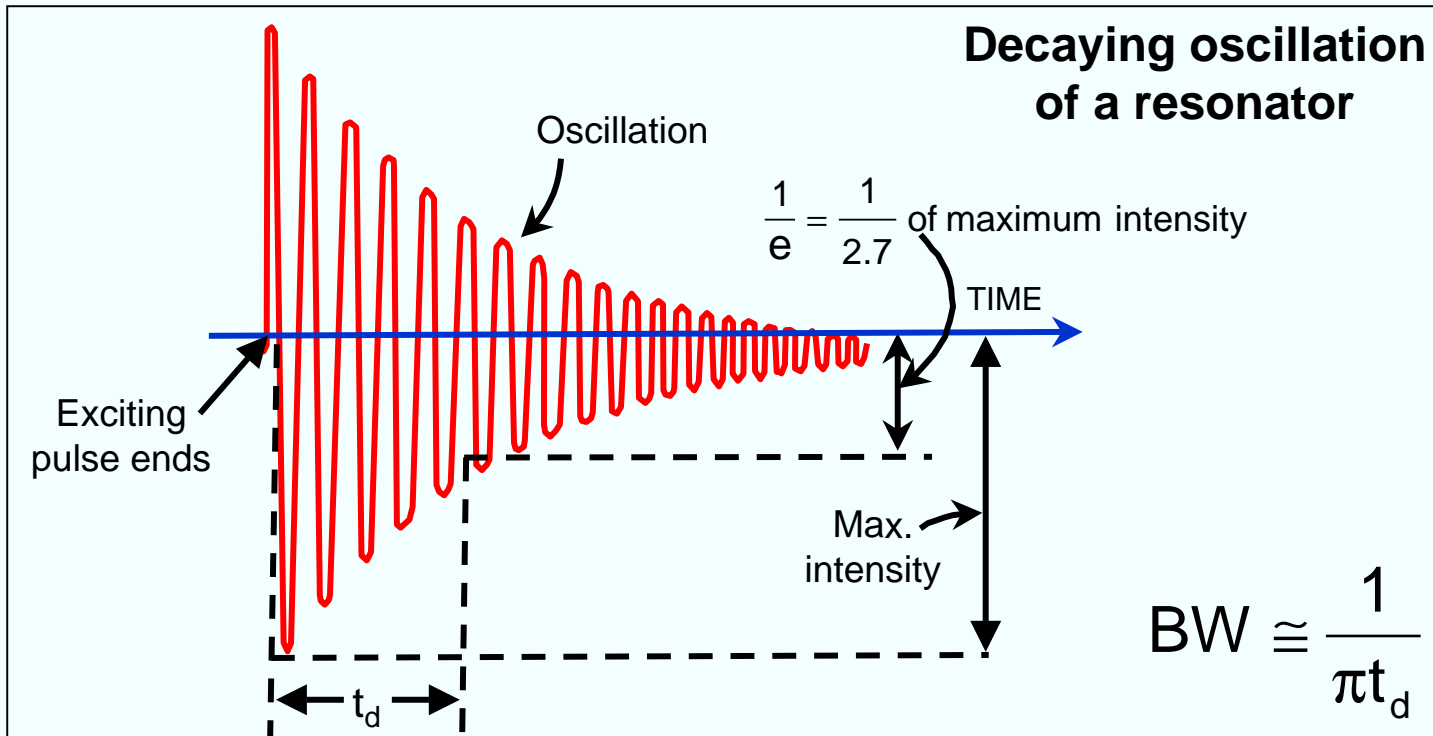

# Factors that Determine Resonator Q

The **maximum Q** of a resonator can be expressed as:

$$Q_{\max} = \frac{1}{2\pi f\tau} ,$$

where  $f$  is the frequency in Hz, and  $\tau$  is an empirically determined “motional time constant” in seconds, which varies with the angles of cut and the mode of vibration. For example,  $\tau = 1 \times 10^{-14}\text{s}$  for the AT-cut's c-mode ( $Q_{\max} = 3.2$  million at 5 MHz),  $\tau = 9.9 \times 10^{-15}\text{s}$  for the SC-cut's c-mode, and  $\tau = 4.9 \times 10^{-15}\text{s}$  for the BT-cut's b-mode.

**Other factors** which affect the Q of a resonator include:

- Overtone
- Surface finish
- Material impurities and defects
- Mounting stresses
- Bonding stresses
- Temperature
- Electrode geometry and type
- Blank geometry (contour, dimensional ratios)
- Drive level
- Gases inside the enclosure (pressure, type of gas)
- Interfering modes
- Ionizing radiation

# Resonator Fabrication Steps

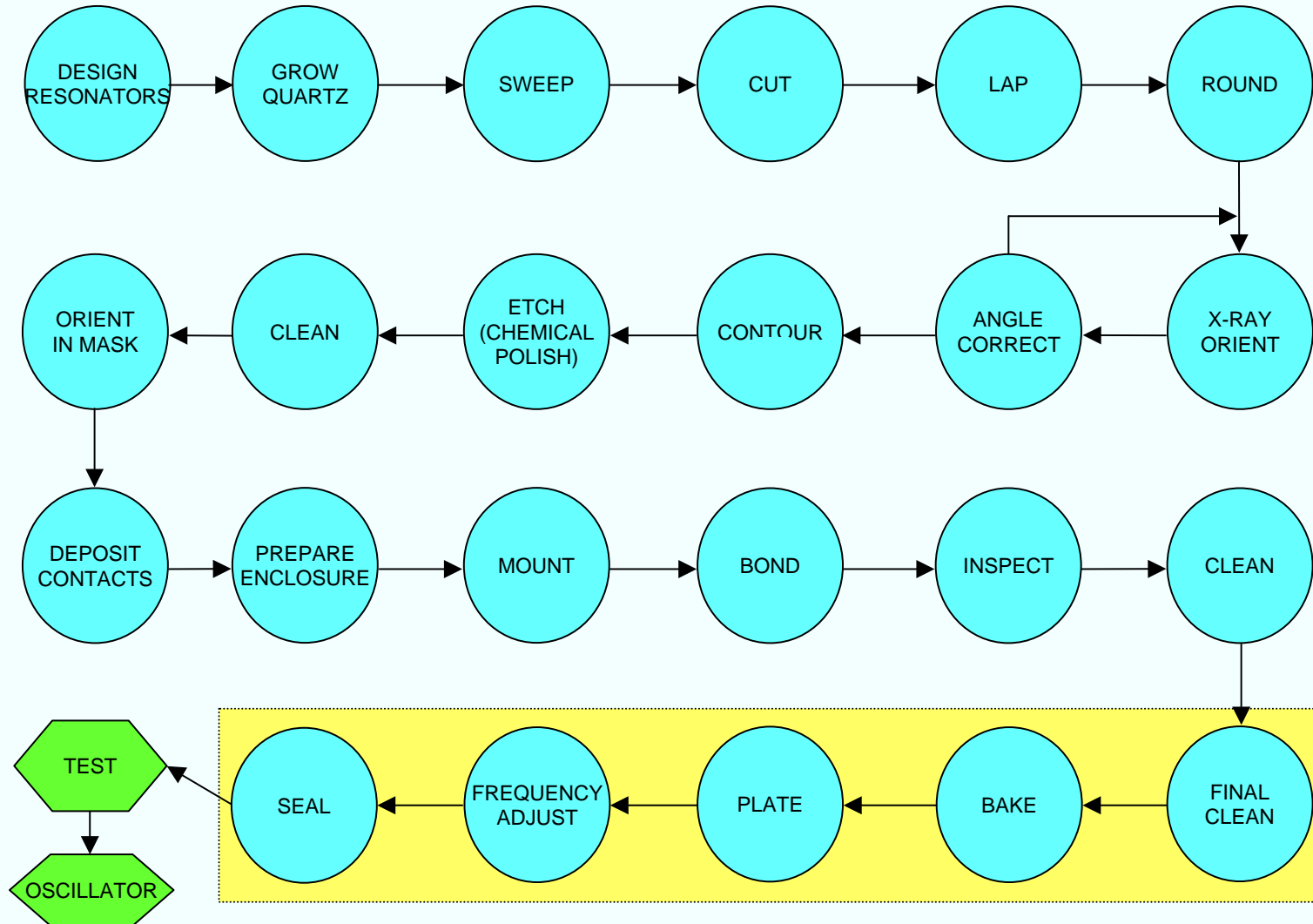

# X-ray Orientation of Crystal Plates

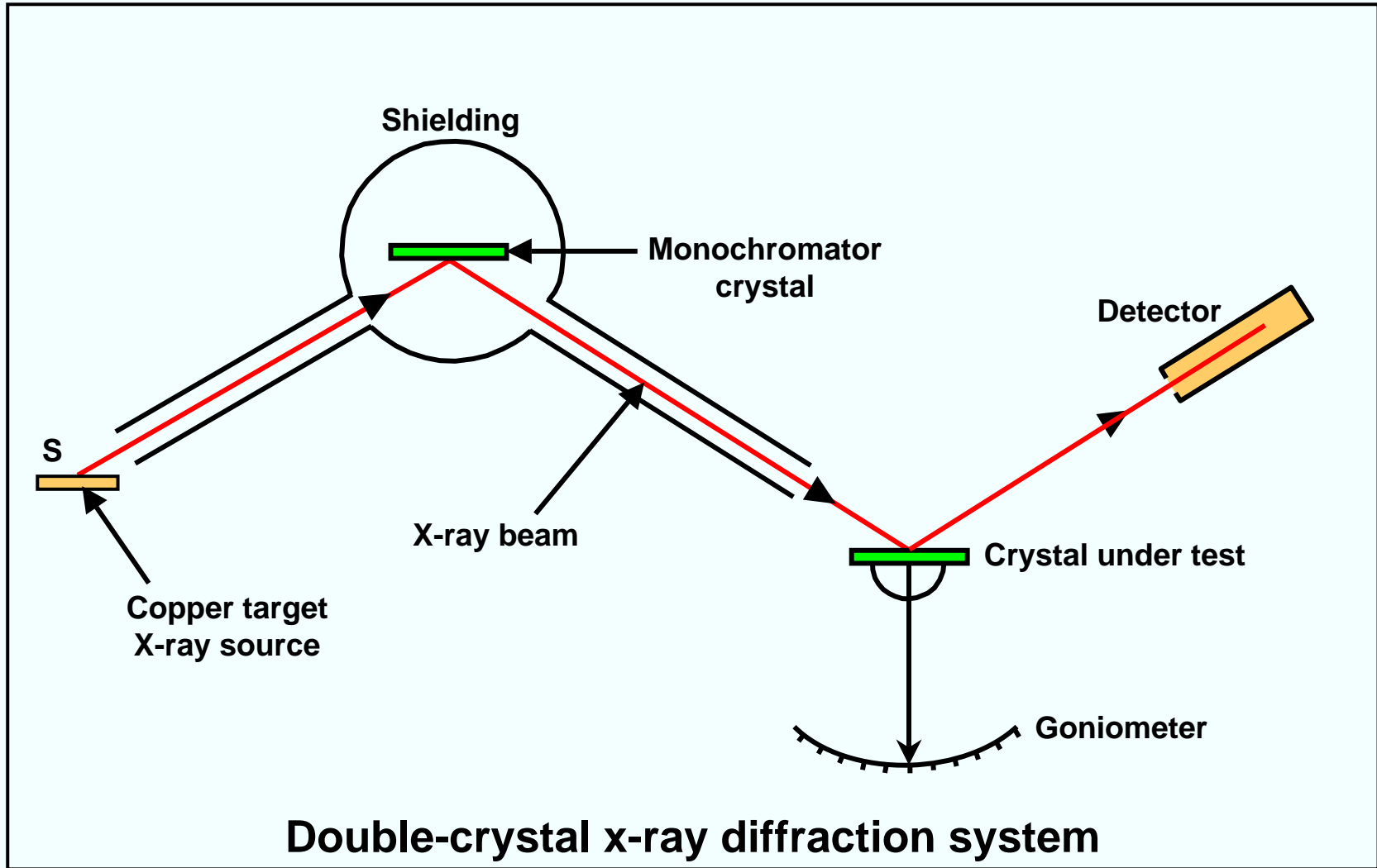



# Contamination Control

Contamination control is essential during the fabrication of resonators because contamination can adversely affect:

- Stability (see [chapter 4](#))
  - [aging](#)
  - [hysteresis](#)
  - [retrace](#)
  - [noise](#)
  - nonlinearities and resistance anomalies ([high starting resistance](#), [second-level of drive](#), intermodulation in filters)
  - [frequency jumps?](#)
- Manufacturing yields
- [Reliability](#)

# Crystal Enclosure Contamination

The enclosure and sealing process can have important influences on resonator stability.

- A monolayer of adsorbed contamination contains  $\sim 10^{15}$  molecules/cm<sup>2</sup> (on a smooth surface)
- An enclosure at  $10^{-7}$  torr contains  $\sim 10^9$  gaseous molecules/cm<sup>3</sup>

## **Therefore:**

In a 1 cm<sup>3</sup> enclosure that has a monolayer of contamination on its inside surfaces, there are  $\sim 10^6$  times more adsorbed molecules than gaseous molecules when the enclosure is sealed at  $10^{-7}$  torr. The desorption and adsorption of such adsorbed molecules leads to aging, hysteresis, noise, etc.

# What is an “f-squared”?

It is standard practice to express the thickness removed by lapping, etching and polishing, and the mass added by the electrodes, in terms of frequency change,  $\Delta f$ , in units of “f<sup>2</sup>”, where the  $\Delta f$  is in kHz and f is in MHz. For example, etching a 10MHz AT-cut plate 1f<sup>2</sup> means that a thickness is removed that produces  $\Delta f= 100$  kHz; and etching a 30 MHz plate 1f<sup>2</sup> means that the  $\Delta f= 900$  kHz. In both cases,  $\Delta f=1f^2$  produces the same thickness change.

To understand this, consider that for a thickness-shear resonator (AT-cut, SC-cut, etc.)

$$f = \frac{N}{t}$$

where f is the fundamental mode frequency, t is the thickness of the resonator plate and N is the frequency constant (1661 MHz• $\mu\text{m}$  for an AT-cut, and 1797 MHz• $\mu\text{m}$  for a SC-cut’s c-mode). Therefore,

$$\frac{\Delta f}{f} = -\frac{\Delta t}{t}$$

and,

$$\Delta t = -N \frac{\Delta f}{f^2}$$

So, for example,  $\Delta f = 1f^2$  corresponds to the same thickness removal for all frequencies. For an AT-cut,  $\Delta t=1.661 \mu\text{m}$  of quartz (=0.83  $\mu\text{m}$  per side) per f<sup>2</sup>. An important advantage of using units of f<sup>2</sup> is that frequency changes can be measured much more accurately than thickness changes. The reason for expressing  $\Delta f$  in kHz and f in MHz is that by doing so, the numbers of f<sup>2</sup> are typically in the range of 0.1 to 10, rather than some very small numbers.

# Milestones in Quartz Technology

- |      |  |
|------|--|
| 1880 | Piezoelectric effect discovered by Jacques and Pierre Curie        |
| 1905 | First hydrothermal growth of quartz in a laboratory - by G. Spezia |
| 1917 | First application of piezoelectric effect, in sonar                |
| 1918 | First use of piezoelectric crystal in an oscillator                |
| 1926 | First quartz crystal controlled broadcast station                  |
| 1927 | First temperature compensated quartz cut discovered                |
| 1927 | First quartz crystal clock built                                   |
| 1934 | First practical temp. compensated cut, the AT-cut, developed       |
| 1949 | Contoured, high-Q, high stability AT-cuts developed                |
| 1956 | First commercially grown cultured quartz available                 |
| 1956 | First TCXO described   |
| 1972 | Miniature quartz tuning fork developed; quartz watches available   |
| 1974 | The SC-cut (and TS/TTC-cut) predicted; verified in 1976            |
| 1982 | First MCXO with dual c-mode self-temperature sensing               |

# Quartz Resonators for Wristwatches

## Requirements:

- Small size
- Low power dissipation (including the oscillator)
- Low cost
- High stability (temperature, aging, shock, attitude)

These requirements can be met with 32,768 Hz quartz tuning forks

# Why 32,768 Hz?

$$32,768 = 2^{15}$$

- In an analog watch, a stepping motor receives one impulse per second which advances the second hand by  $6^\circ$ , i.e.,  $1/60$ th of a circle, every second.
- Dividing 32,768 Hz by two 15 times results in 1 Hz.
- The 32,768 Hz is a compromise among size, power requirement (i.e., battery life) and stability.

32,768  
16,384  
8,192  
4,096  
2,048  
1,024  
512  
256  
128  
64  
32  
16  
8  
4  
2  
1

# Quartz Tuning Fork

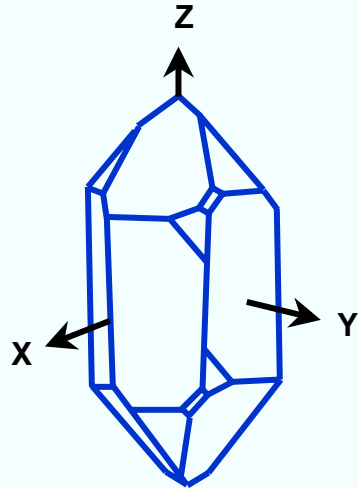

a) natural faces and crystallographic axes of quartz

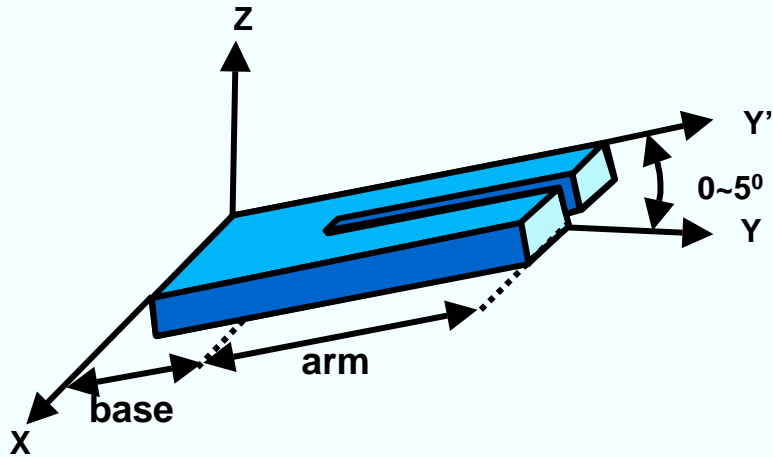

b) crystallographic orientation of tuning fork

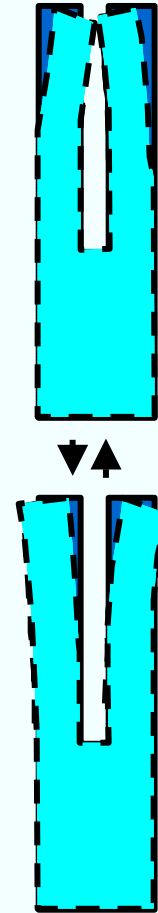

c) vibration mode of tuning fork

# Watch Crystal

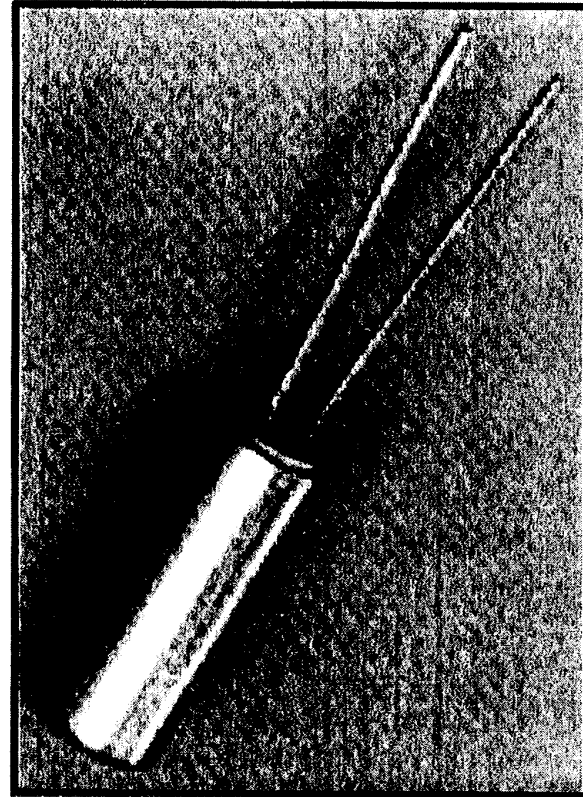
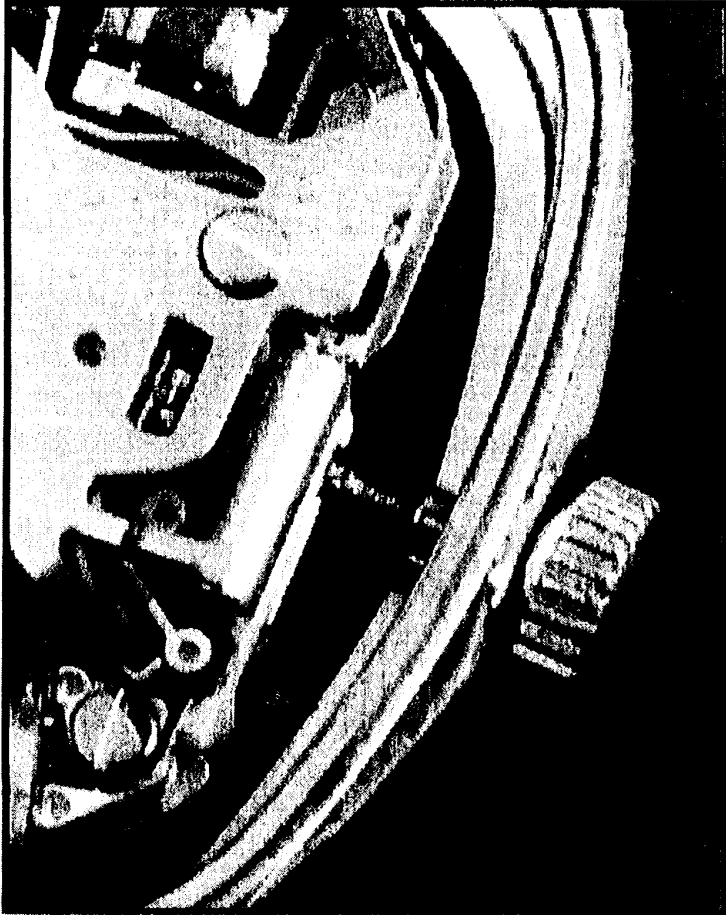

2 mm diameter x 6 mm tall cylinder  
(0.08" diameter x 0.24" tall)



# Lateral Field Resonator

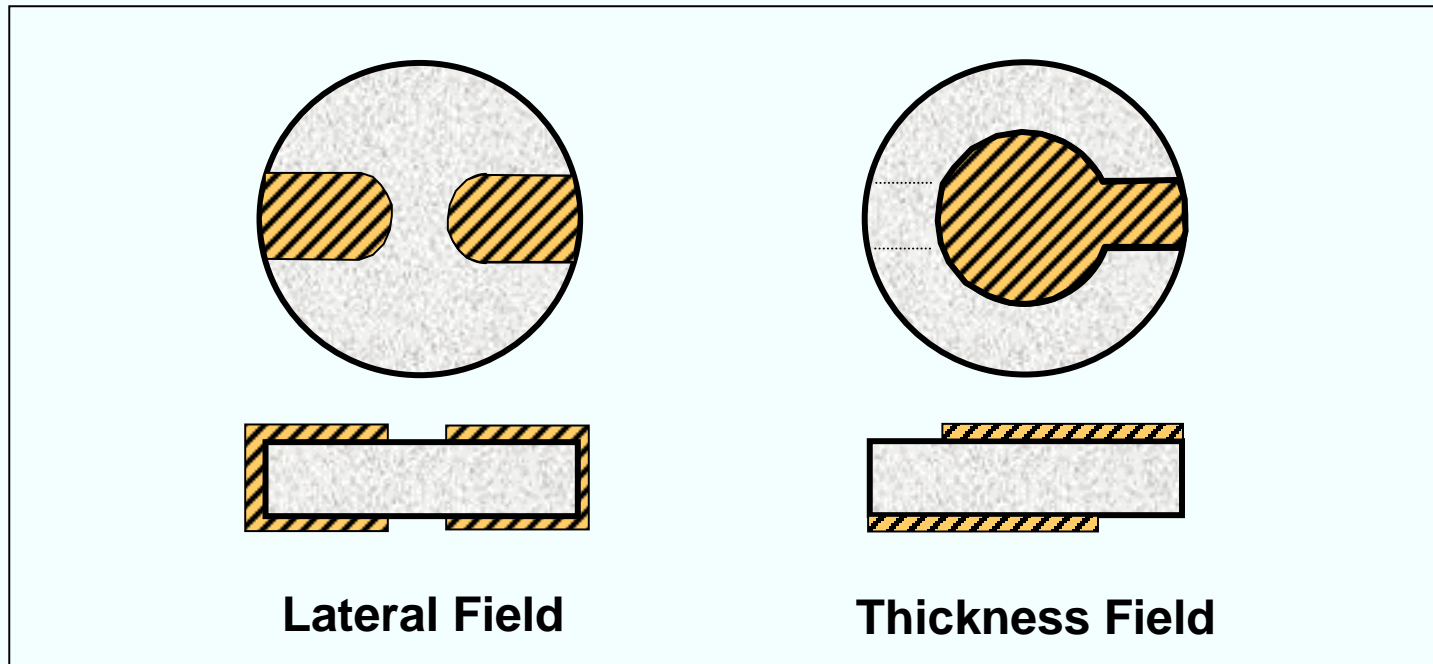

In lateral field resonators (LFR): 1. the electrodes are absent from the regions of greatest motion, and 2. varying the orientation of the gap between the electrodes varies certain important resonator properties. Advantages of LFR are:

- Ability to eliminate undesired modes, e.g., the b-mode in SC-cuts
- Potentially higher Q (less damping due to electrodes and mode traps)
- Potentially higher stability (less electrode and mode trap effects, smaller  $C_1$ )

# Electrodeless (BVA) Resonator

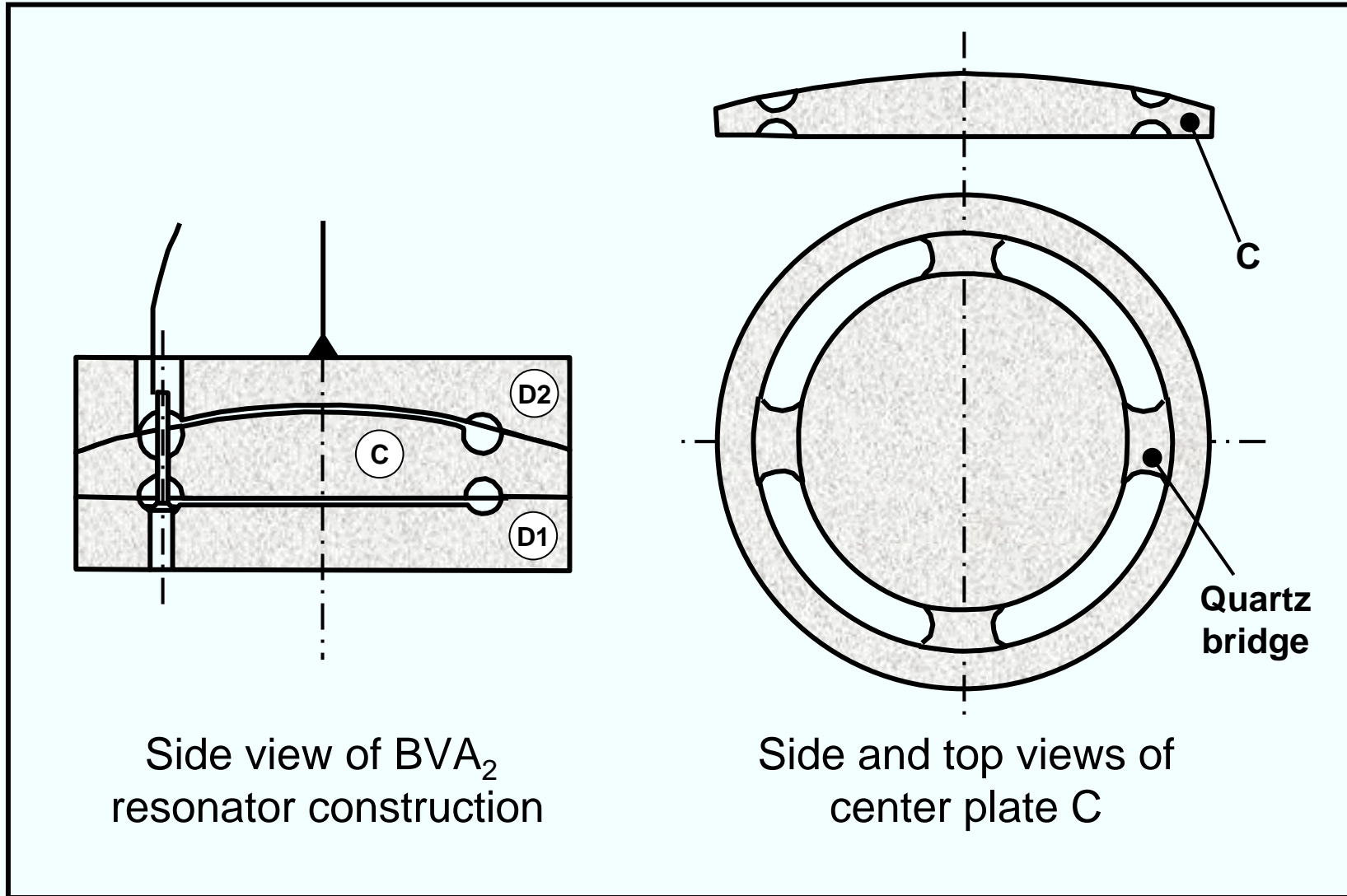

**CHAPTER 4**  
**Oscillator Stability**

# The Units of Stability in Perspective

- What is one part in  $10^{10}$  ? (As in  $1 \times 10^{-10}$ /day aging.)
  - $\sim 1/2$  cm out of the circumference of the earth.
  - $\sim 1/4$  second per human lifetime (of  $\sim 80$  years).
- What is -170 dB? (As in -170 dBc/Hz phase noise.)
  - -170 dB = 1 part in  $10^{17} \approx$  thickness of a sheet of paper out of total distance traveled by all the cars in the world in a day.

# Accuracy, Precision, and Stability

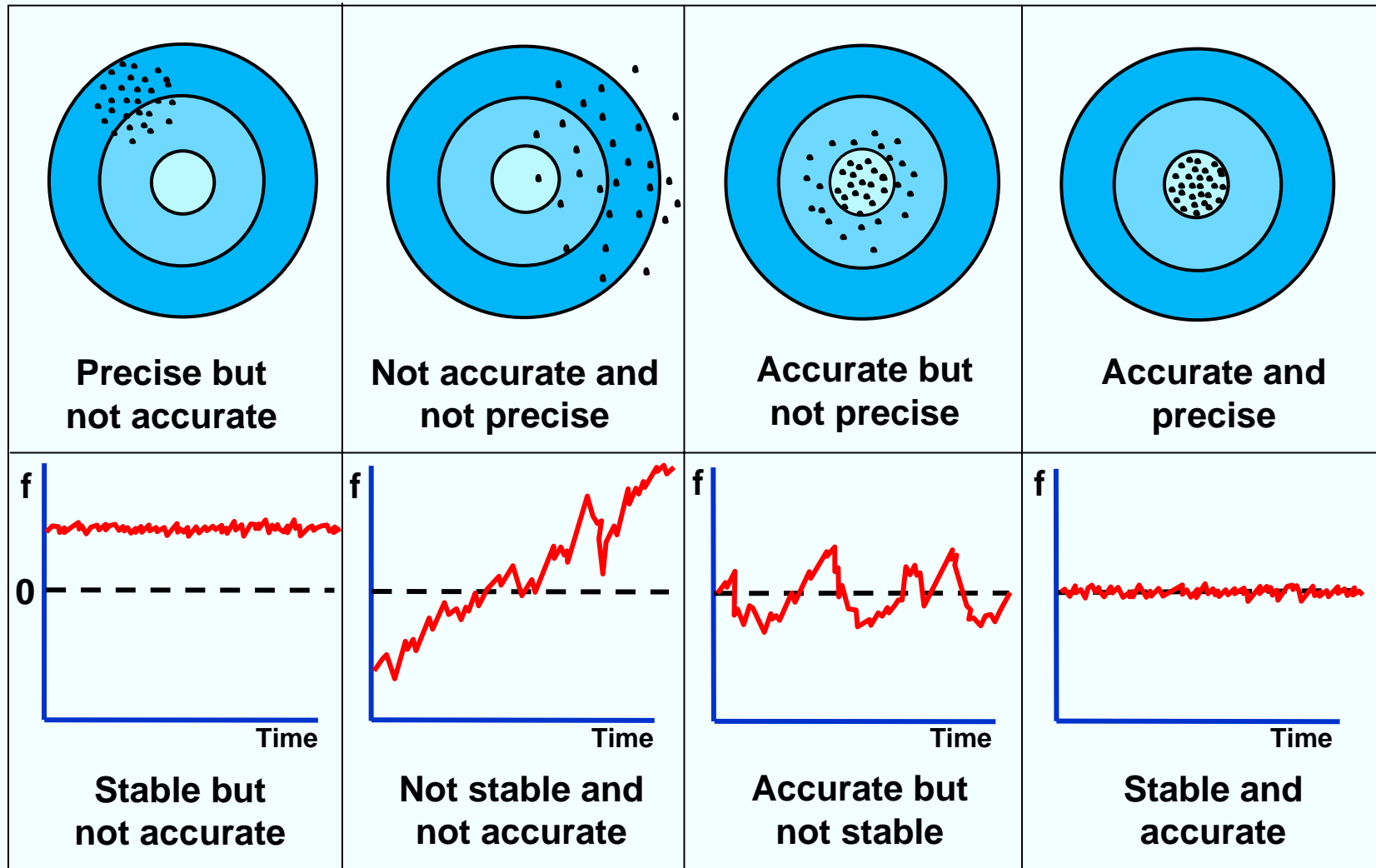

# Influences on Oscillator Frequency

- **Time**
  - Short term (noise)
  - Intermediate term (e.g., due to oven fluctuations)
  - Long term (aging)
- **Temperature**
  - Static frequency vs. temperature
  - Dynamic frequency vs. temperature (warmup, thermal shock)
  - Thermal history ("hysteresis," "retrace")
- **Acceleration**
  - Gravity (2g tipover)
  - Vibration
  - Acoustic noise
  - Shock
- **Ionizing radiation**
  - Steady state
  - Pulsed
  - Photons (X-rays,  $\gamma$ -rays)
  - Particles (neutrons, protons, electrons)
- **Other**
  - Power supply voltage
  - Atmospheric pressure (altitude)
  - Humidity
  - Load impedance
  - Magnetic field

# Idealized Frequency-Time-Influence Behavior

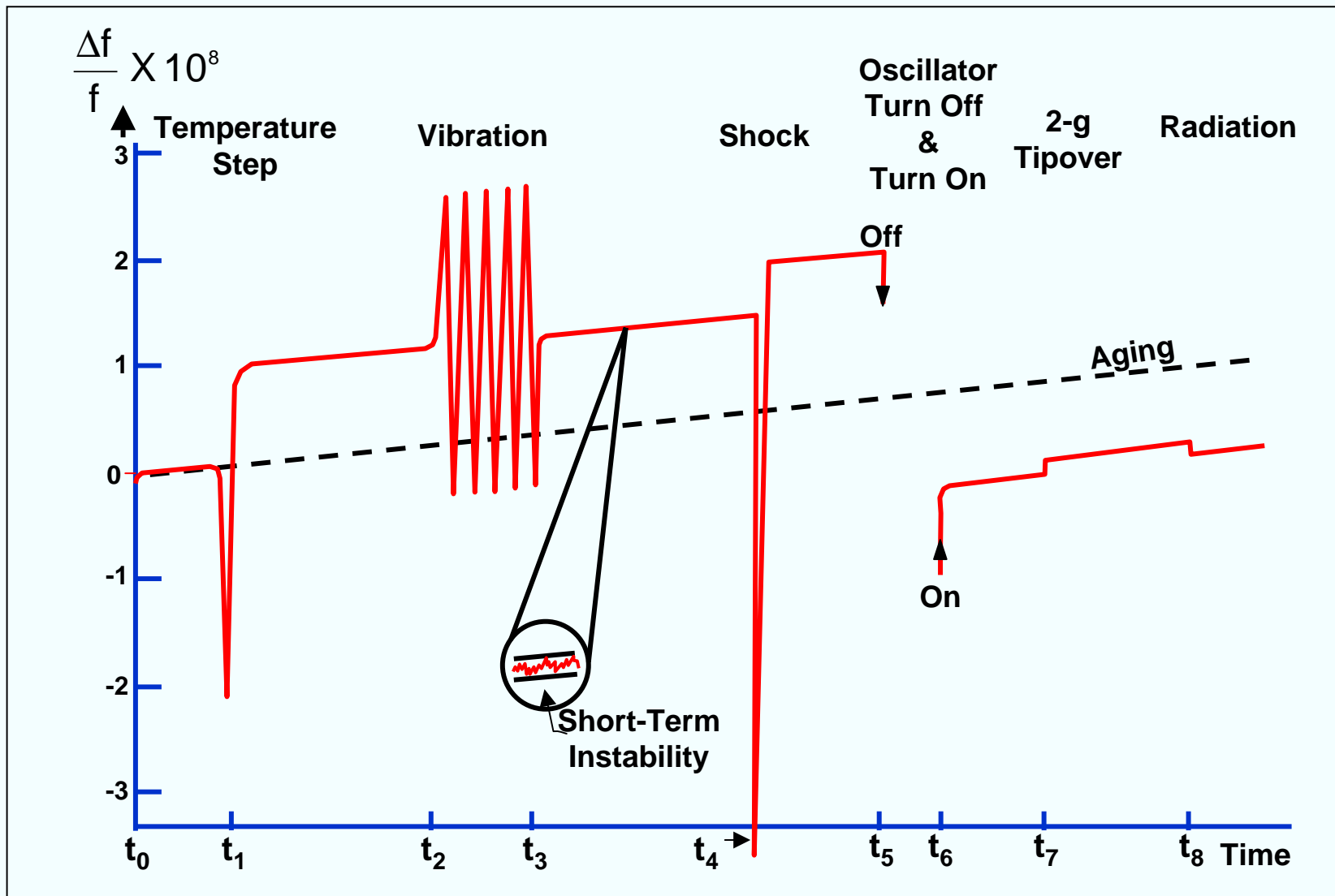

# Aging and Short-Term Stability

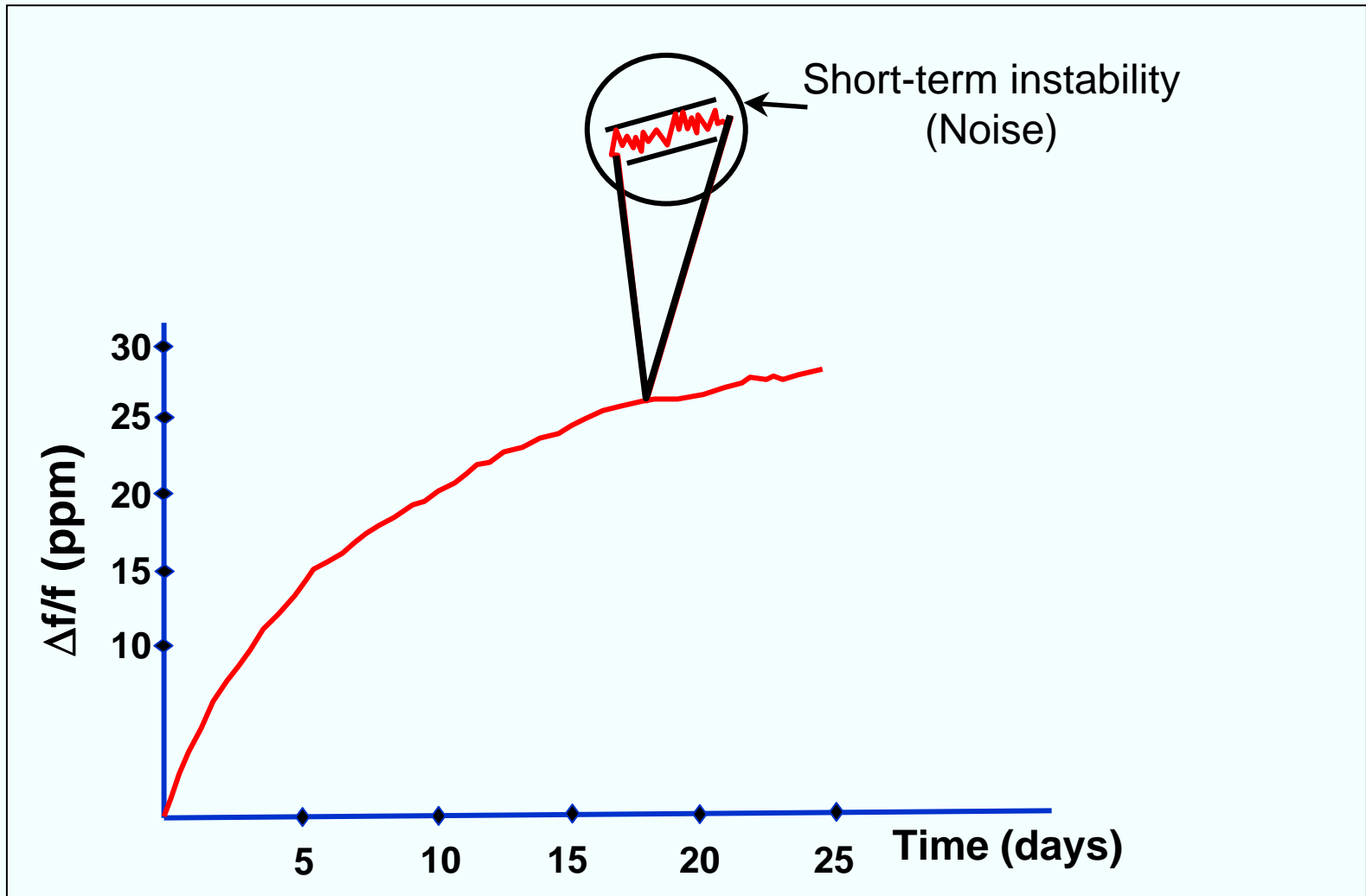



# Aging Mechanisms

- **Mass transfer due to contamination**

Since  $f \propto 1/t$ ,  $\Delta f/f = -\Delta t/t$ ; e.g.,  $f_{5\text{MHz}} \approx 10^6$  molecular layers, therefore, 1 quartz-equivalent monolayer  $\Rightarrow \Delta f/f \approx 1$  ppm

- **Stress relief** in the resonator's: mounting and bonding structure, electrodes, and in the quartz (?)

- **Other effects**

- Quartz outgassing
- Diffusion effects
- Chemical reaction effects
- Pressure changes in resonator enclosure (leaks and outgassing)
- Oscillator circuit aging (load reactance and drive level changes)
- Electric field changes (doubly rotated crystals only)
- Oven-control circuitry aging

# Typical Aging Behaviors

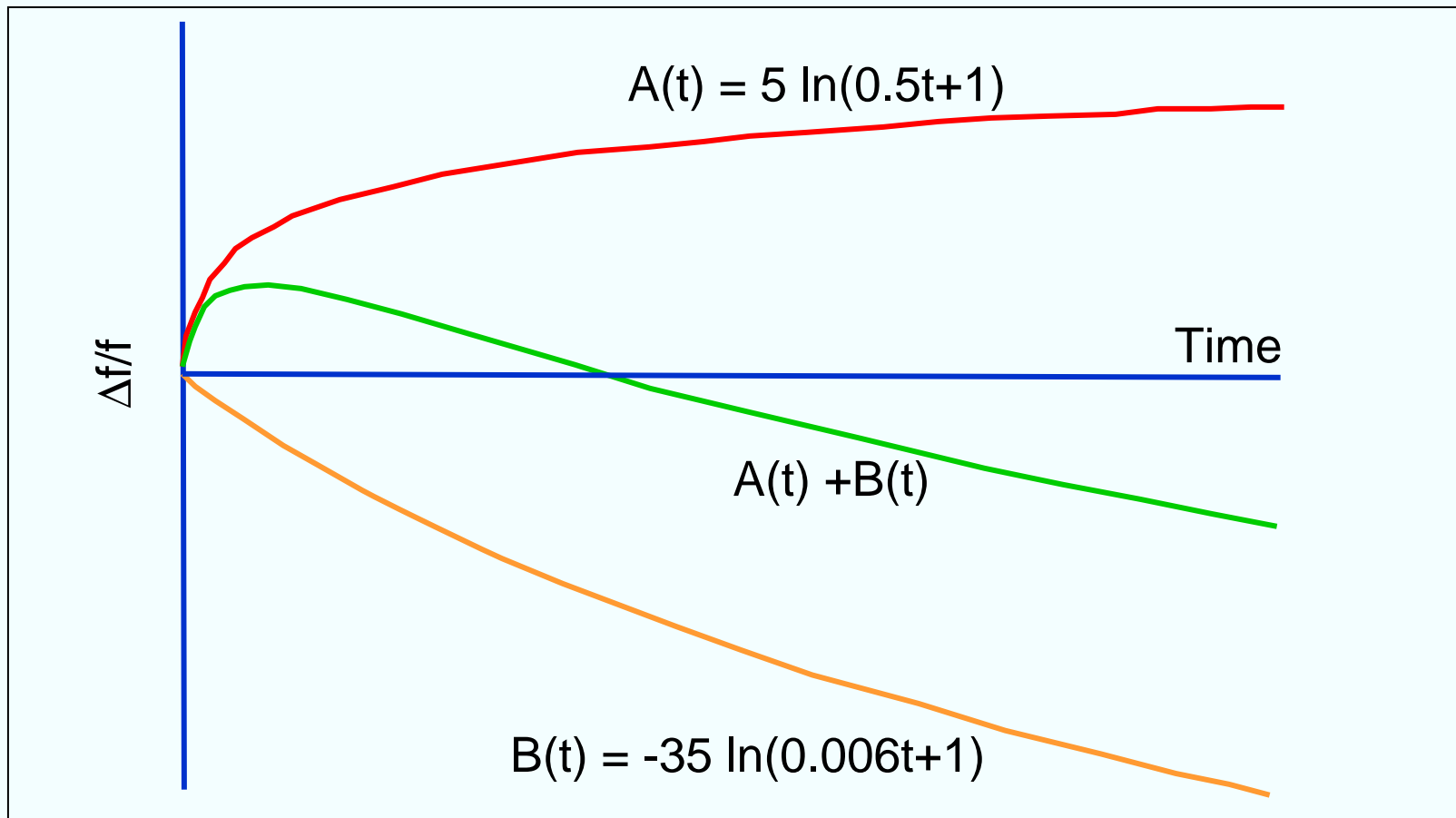

# Stresses on a Quartz Resonator Plate

## Causes:

- Thermal expansion coefficient differences
- Bonding materials changing dimensions upon solidifying/curing
- Residual stresses due to clip forming and welding operations, sealing
- Intrinsic stresses in electrodes
- Nonuniform growth, impurities & other defects during quartz growing
- Surface damage due to cutting, lapping and (mechanical) polishing

## Effects:

- In-plane diametric forces
- Tangential (torsional) forces, especially in 3 and 4-point mounts
- Bending (flexural) forces, e.g., due to clip misalignment and electrode stresses
- Localized stresses in the quartz lattice due to dislocations, inclusions, other impurities, and surface damage

# Thermal Expansion Coefficients of Quartz

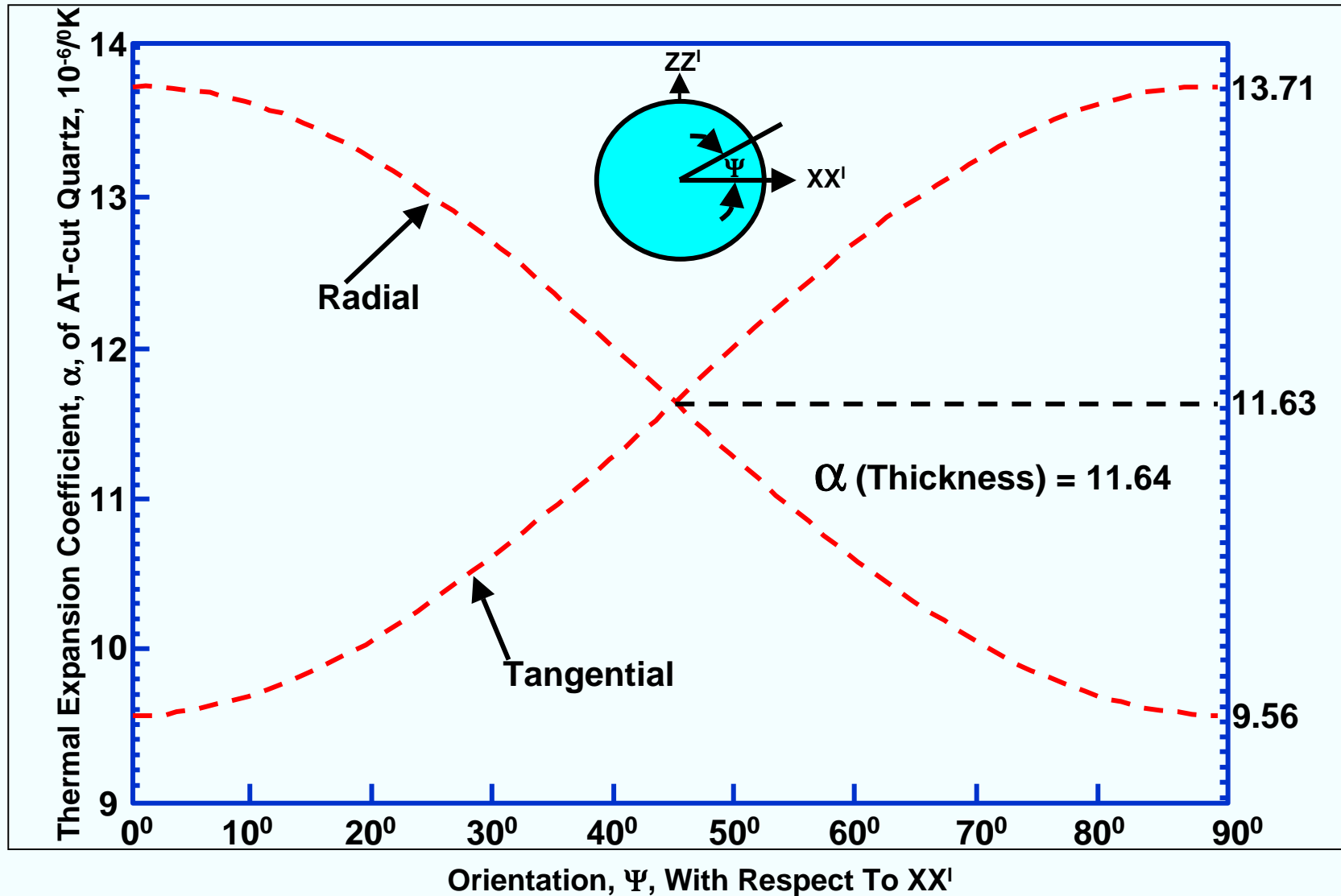

# Force-Frequency Coefficient

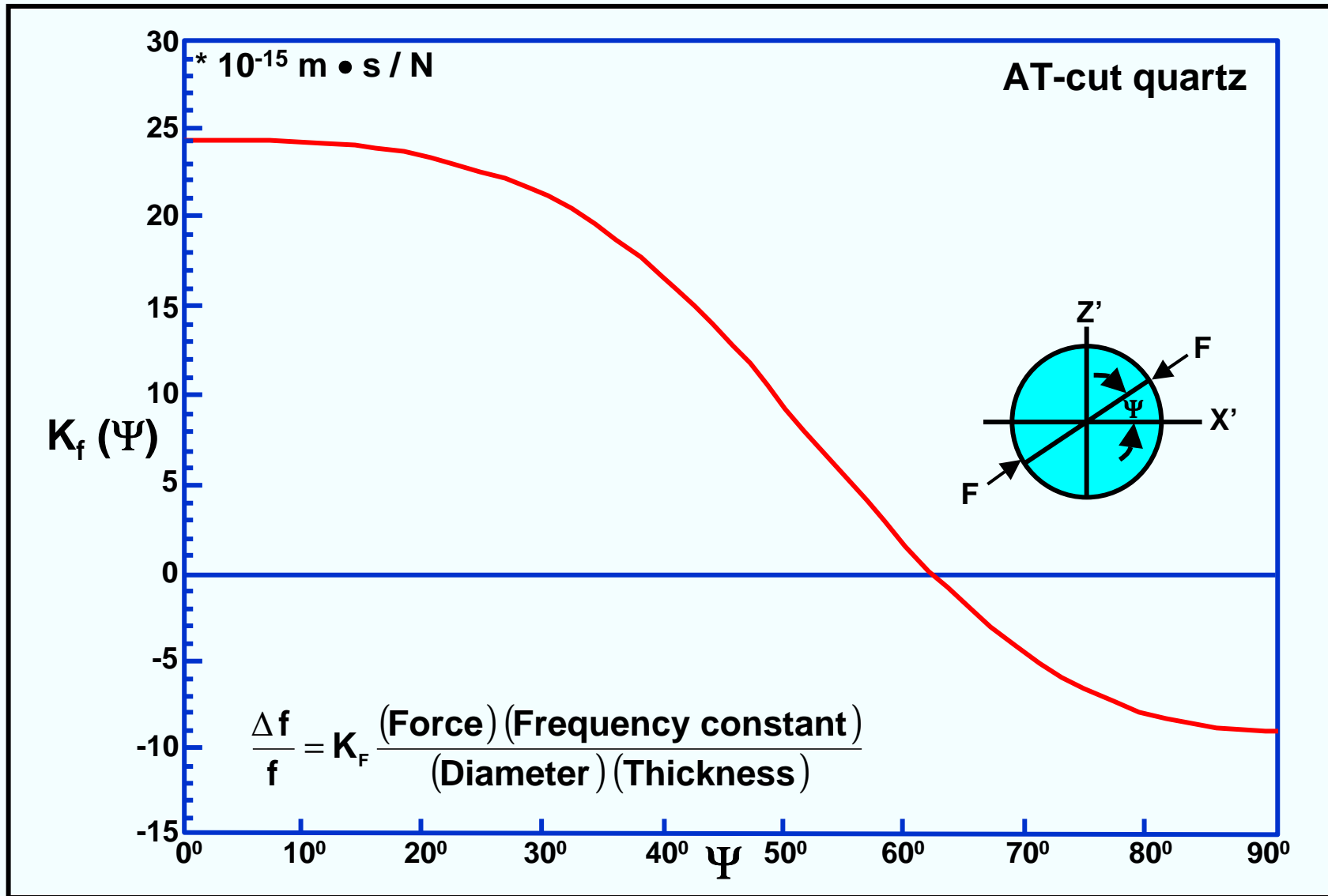

# Strains Due To Mounting Clips

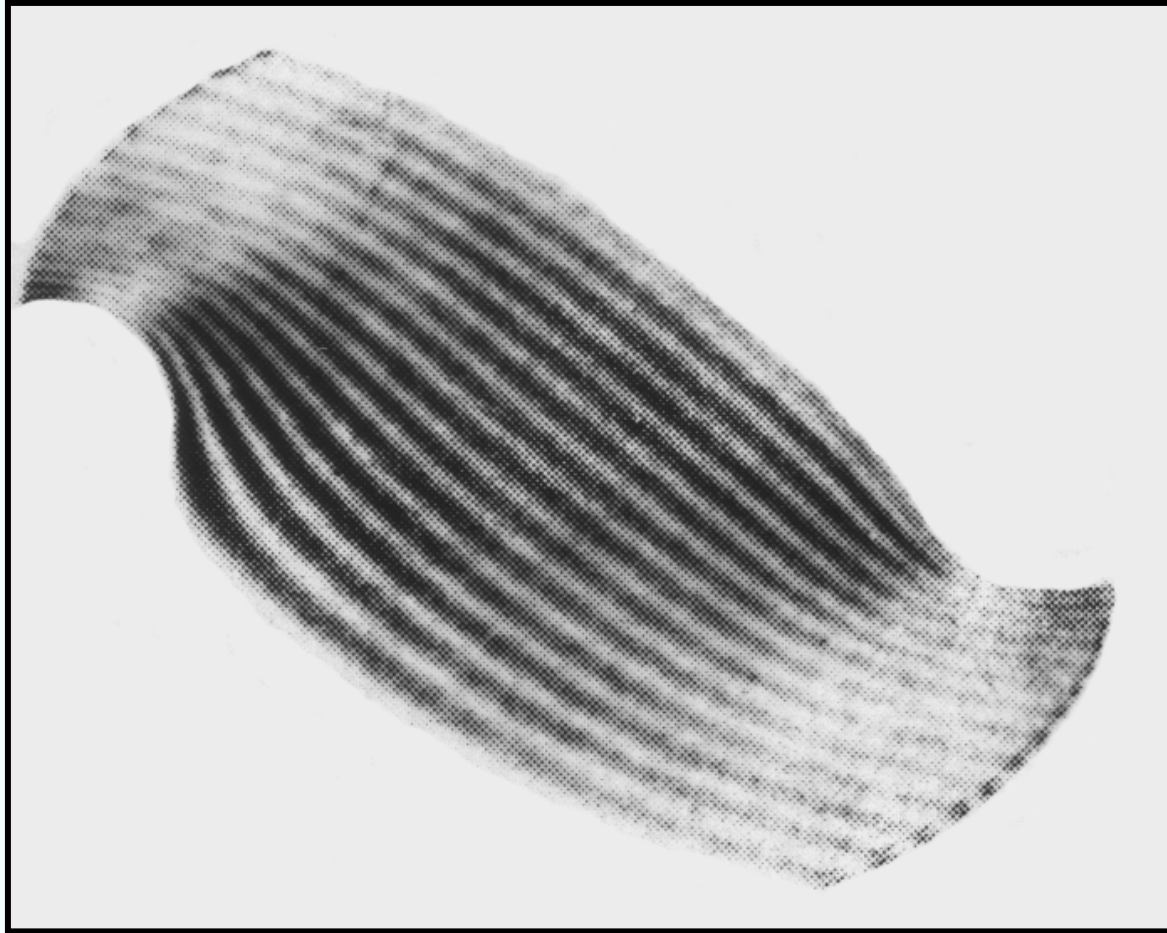

X-ray topograph of an AT-cut, two-point mounted resonator. The topograph shows the lattice deformation due to the stresses caused by the mounting clips.

# Strains Due To Bonding Cements

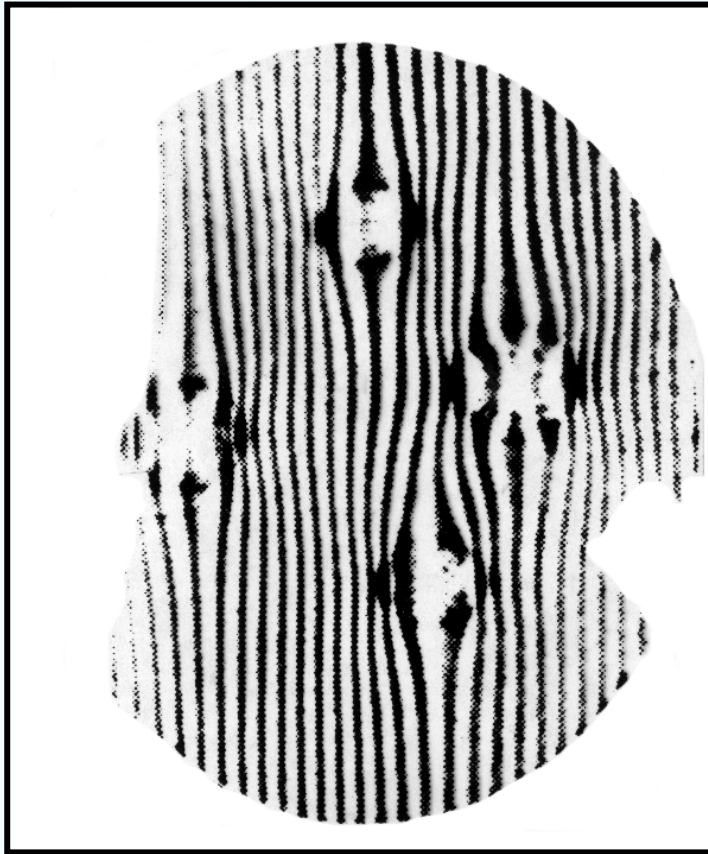

(a)

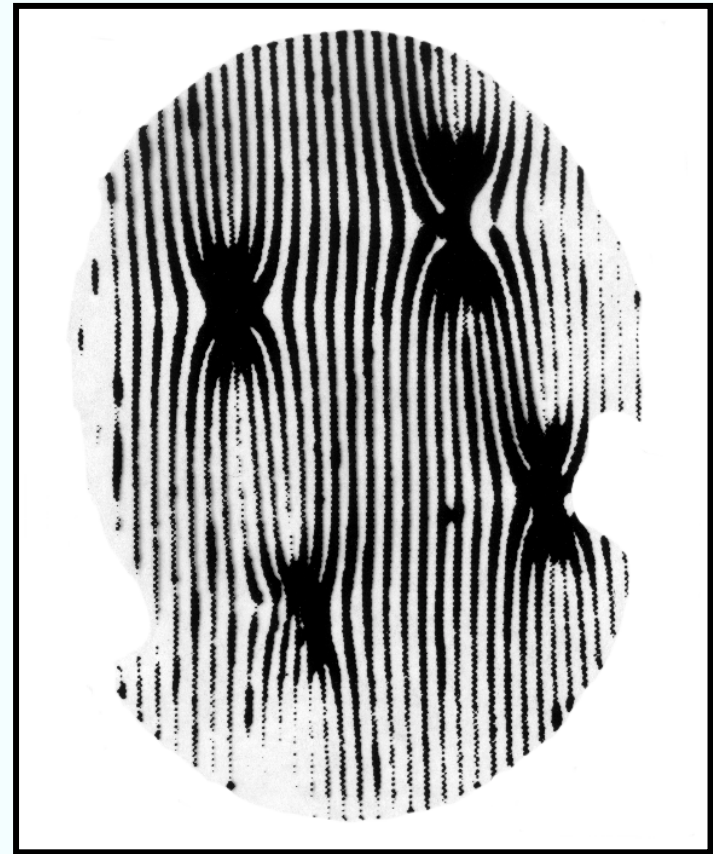

(b)

X-ray topographs showing lattice distortions caused by bonding cements; (a) Bakelite cement - expanded upon curing, (b) DuPont 5504 cement - shrank upon curing

# Mounting Force Induced Frequency Change

The force-frequency coefficient,  $K_F(\psi)$ , is defined by

$$\frac{\Delta f}{f} = K_F \frac{(\text{Force}) (\text{Frequency} - \text{constant})}{(\text{Diameter}) (\text{Thickness})}$$

Maximum  $K_F$  (AT-cut) =  $24.5 \times 10^{-15}$  m-s/N at  $\psi = 0^\circ$

Maximum  $K_F$  (SC-cut) =  $14.7 \times 10^{-15}$  m-s/N at  $\psi = 44^\circ$

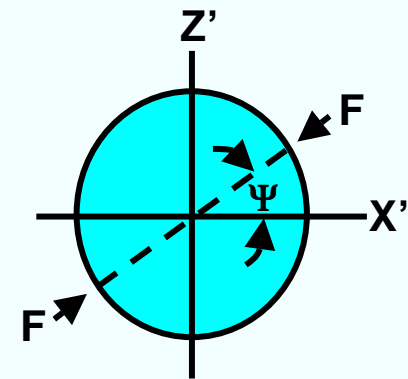

As an example, consider a 5 MHz 3rd overtone, 14 mm diameter resonator. Assuming the presence of diametrical forces only, ( $1 \text{ gram} = 9.81 \times 10^{-3}$  newtons),

$$\left( \frac{\Delta f}{f} \right)_{\text{Max}} = \begin{cases} 2.9 \times 10^{-8} \text{ per gram for an AT-cut resonator} \\ 1.7 \times 10^{-8} \text{ per gram for an SC-cut resonator} \end{cases}$$

$$\left( \frac{\Delta f}{f} \right)_{\text{Min}} = 0 \text{ at } \psi = 61^\circ \text{ for an AT-cut resonator, and at } \psi = 82^\circ \text{ for an SC-cut.}$$



# Bonding Strains Induced Frequency Changes

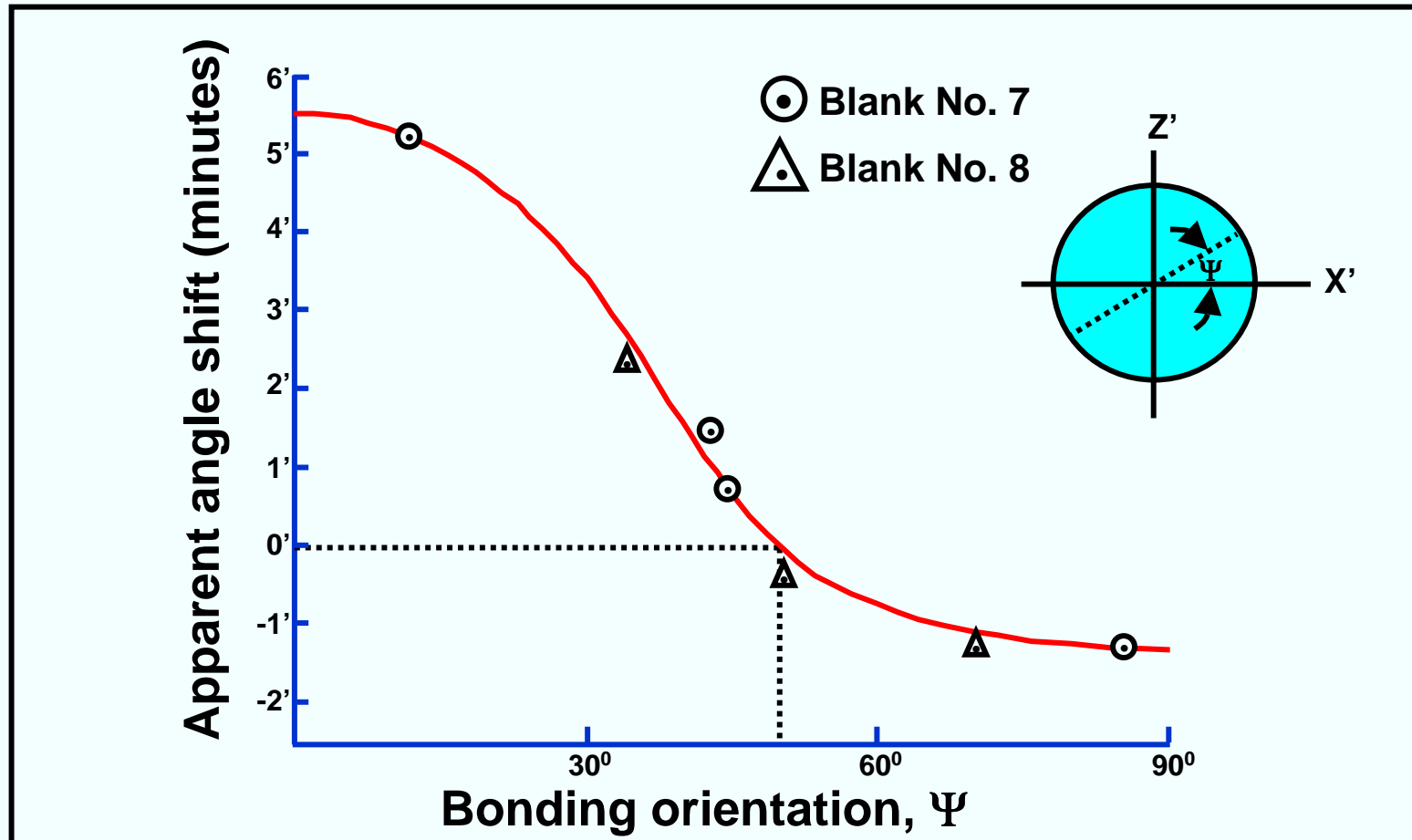

When 22 MHz fundamental mode AT-cut resonators were reprocessed so as to vary the bonding orientations, the frequency vs. temperature characteristics of the resonators changed as if the angles of cut had been changed. The resonator blanks were 6.4 mm in diameter plano-plano, and were bonded to low-stress mounting clips by nickel electrobonding.

# Bending Force vs. Frequency Change

AT-cut resonator

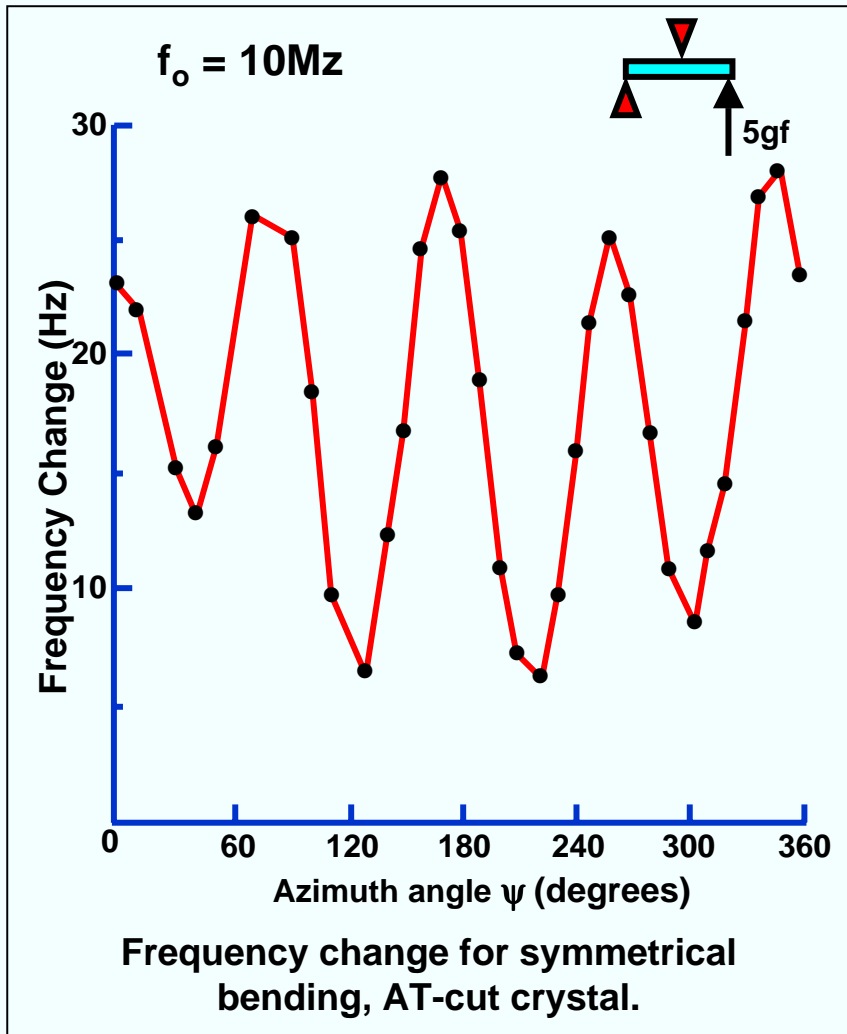

SC-cut resonator

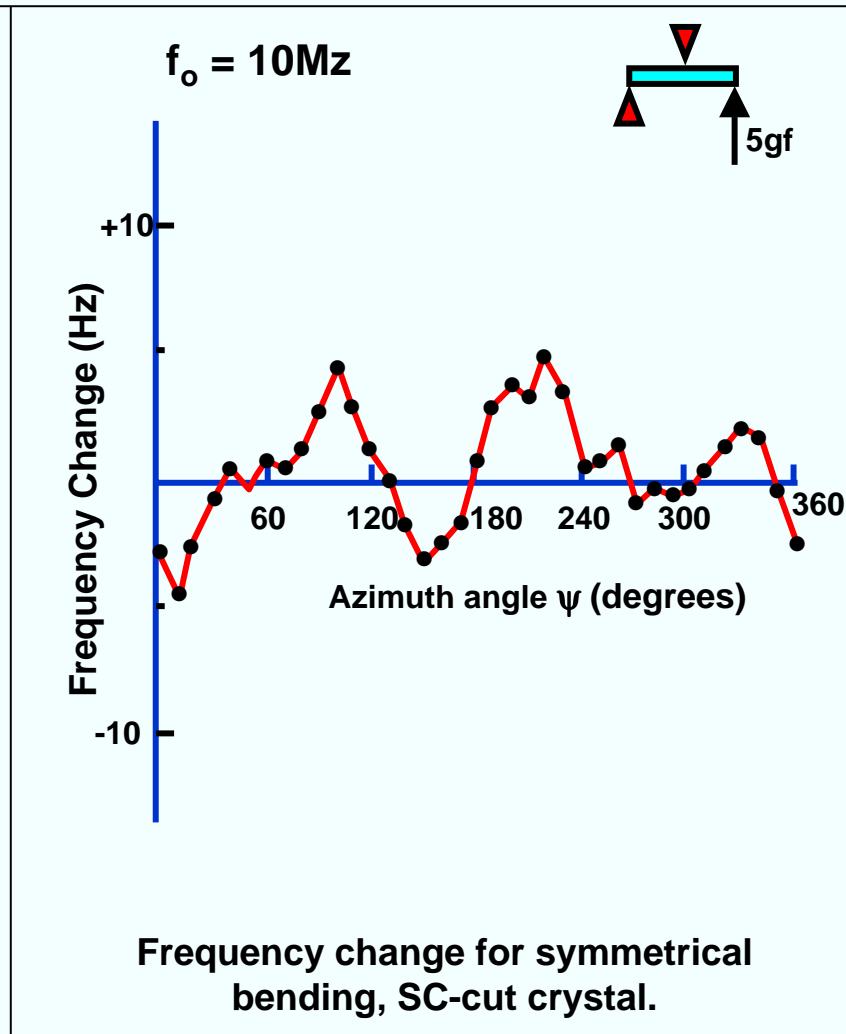

# Short Term Instability (Noise)

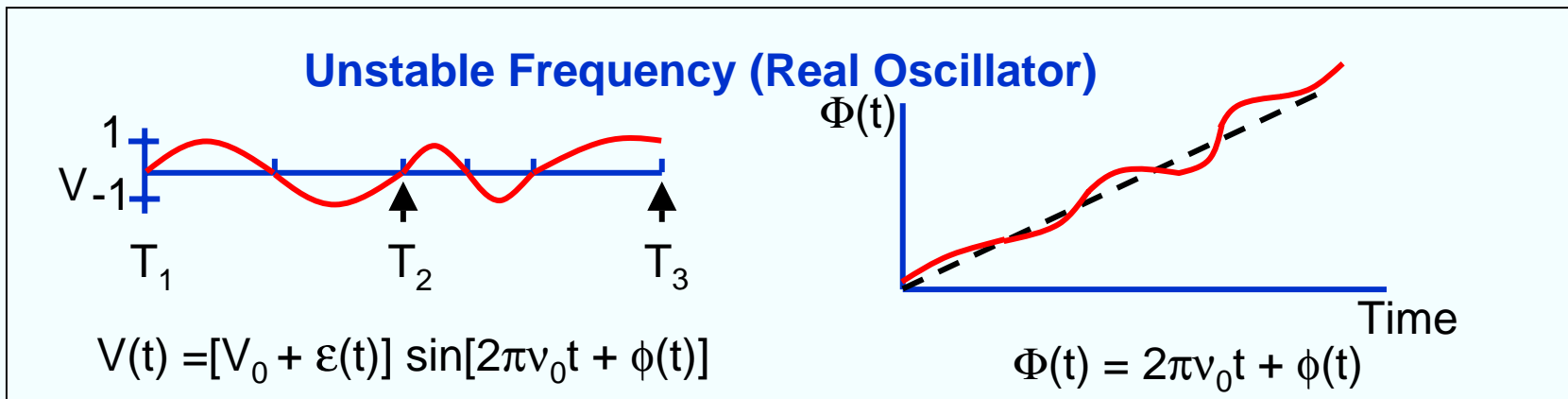
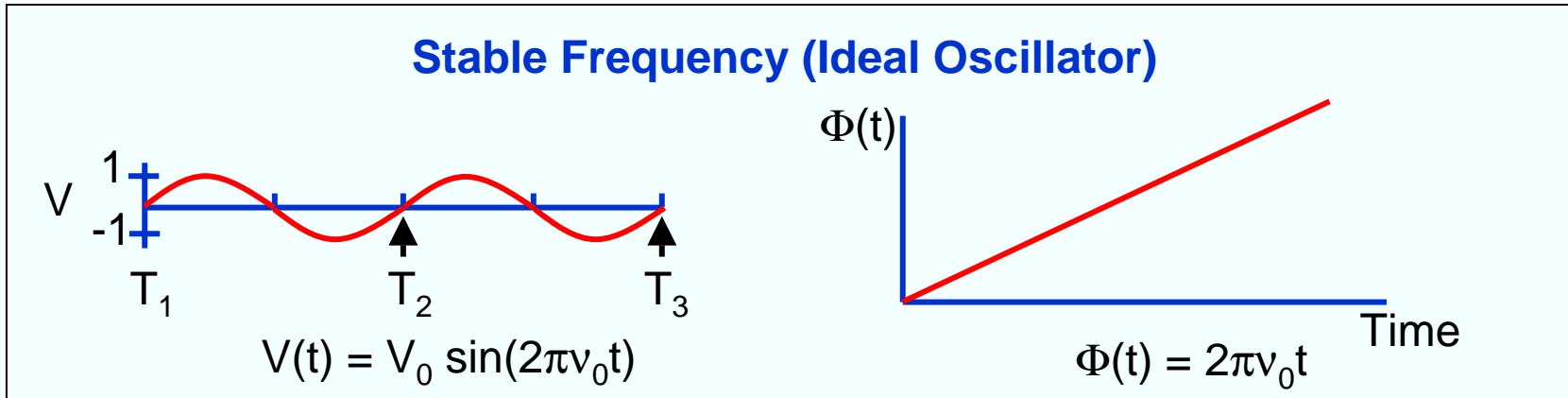

**Instantaneous frequency,  $\nu(t) = \frac{1}{2\pi} \frac{d\Phi(t)}{dt} = \nu_0 + \frac{1}{2\pi} \frac{d\phi(t)}{dt}$**

$V(t)$  = Oscillator output voltage,

$V_0$  = Nominal peak voltage amplitude

$\varepsilon(t)$  = Amplitude noise,

$\nu_0$  = Nominal (or "carrier") frequency

$\Phi(t)$  = Instantaneous phase, and  $\phi(t)$  = Deviation of phase from nominal (i.e., the ideal)

# Instantaneous Output Voltage of an Oscillator

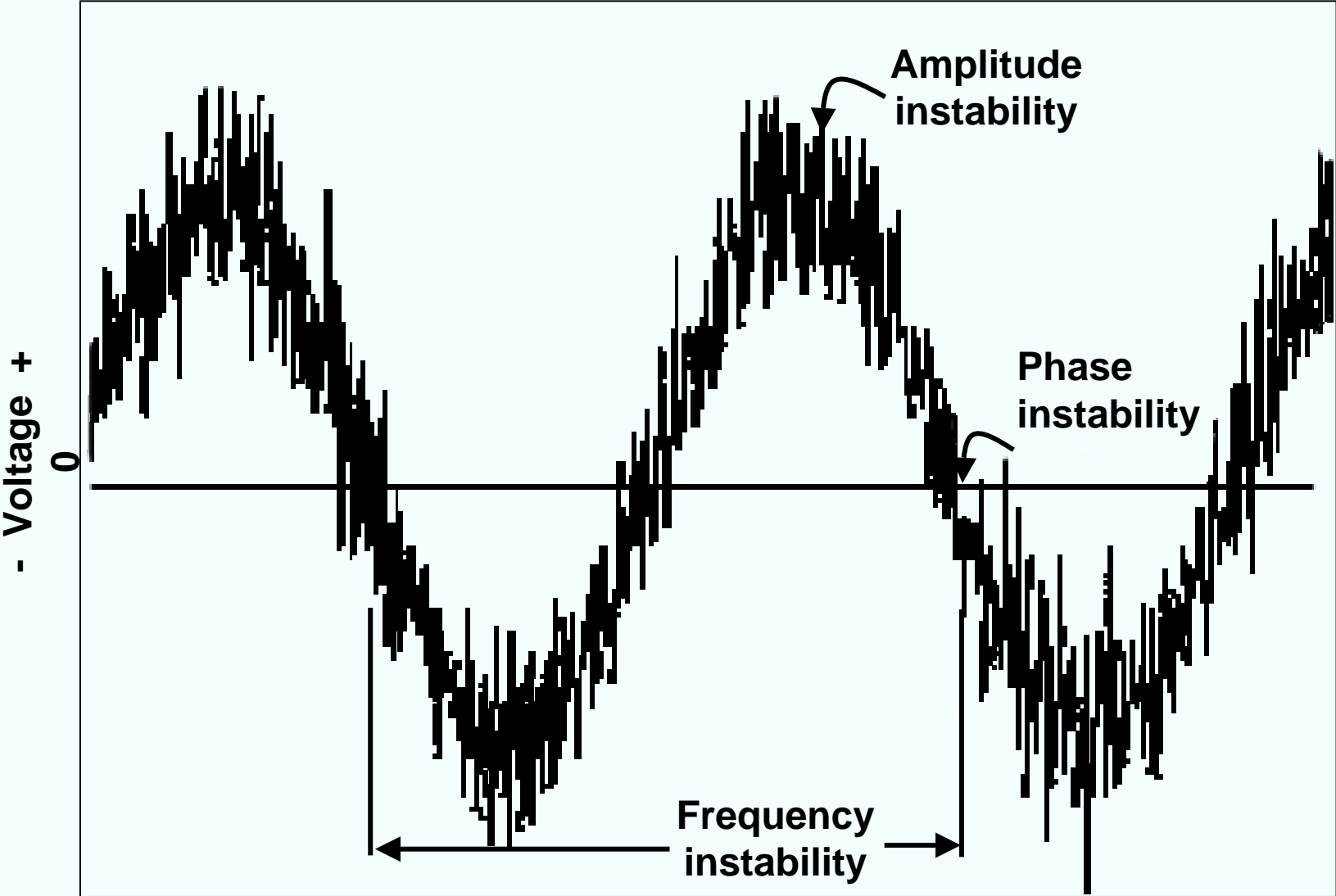

Time

# Impacts of Oscillator Noise

- Limits the ability to determine the current state and the predictability of oscillators
- Limits syntonization and synchronization accuracy
- Limits receivers' useful dynamic range, channel spacing, and selectivity; can limit jamming resistance
- Limits radar performance (especially Doppler radar's)
- Causes timing errors [ $\sim \tau \sigma_y(\tau)$ ]
- Causes bit errors in digital communication systems
- Limits number of communication system users, as noise from transmitters interfere with receivers in nearby channels
- Limits navigation accuracy
- Limits ability to lock to narrow-linewidth resonances
- Can cause loss of lock; can limit acquisition/reacquisition capability in phase-locked-loop systems

# Time Domain - Frequency Domain

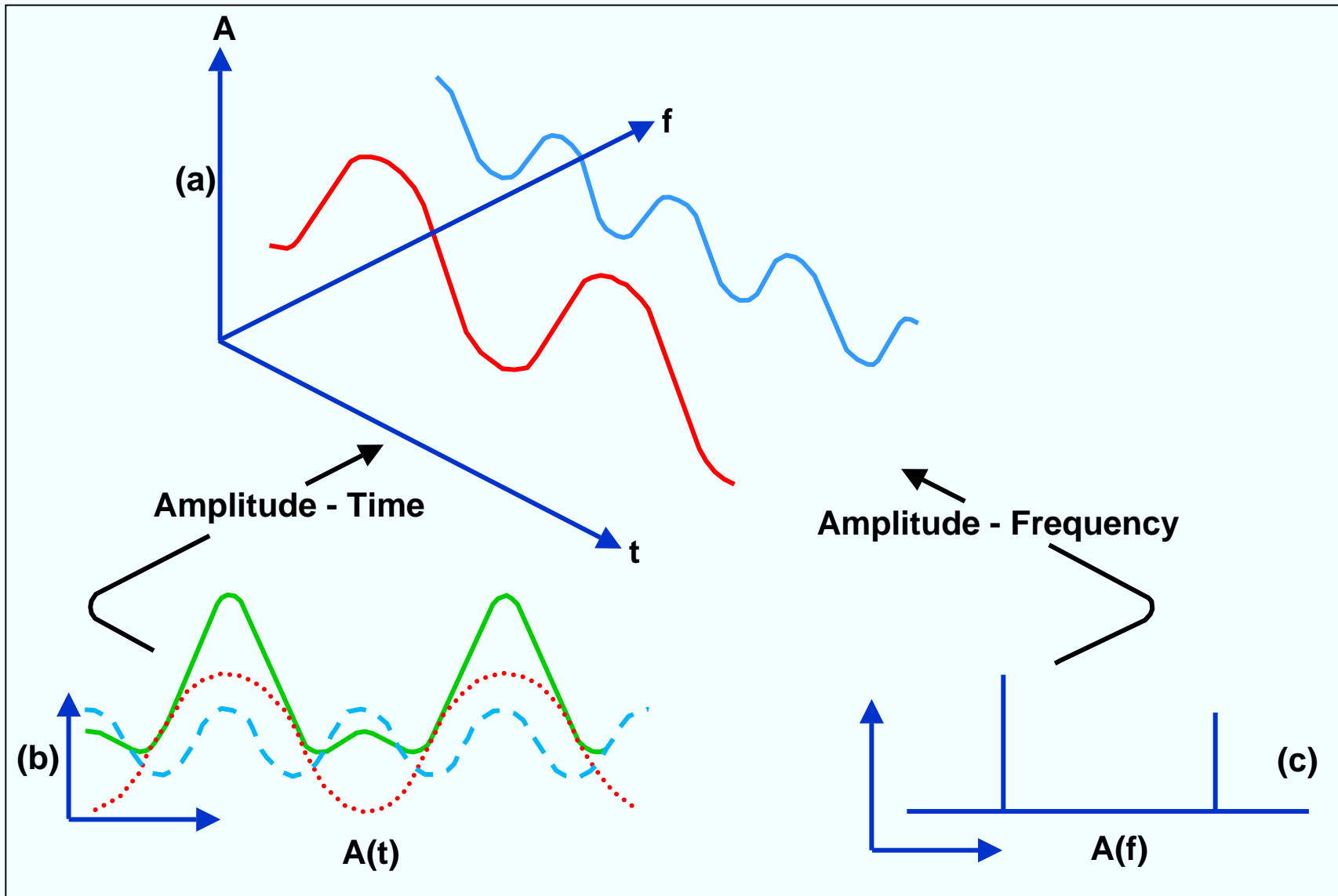

# Causes of Short Term Instabilities

- Johnson noise (thermally induced charge fluctuations, i.e., "thermal emf" in resistive elements)
- Phonon scattering by defects & quantum fluctuations (related to Q)
- Noise due to oscillator circuitry (active and passive components)
- Temperature fluctuations- thermal transient effects
  - activity dips at oven set-point
- Random vibration
- Fluctuations in the number of adsorbed molecules
- Stress relief, fluctuations at interfaces (quartz, electrode, mount, bond)
- Shot noise in atomic frequency standards
- ? ? ?

# Short-Term Stability Measures

Measure	Symbol
Two-sample deviation, also called “Allan deviation” Spectral density of phase deviations Spectral density of fractional frequency deviations Phase noise  * Most frequently found on oscillator specification sheets	$\sigma_y(\tau)^*$ $S_\phi(f)$ $S_y(f)$ $L(f)^*$

$$f^2 S_\phi(f) = v^2 S_y(f); \quad L(f) \equiv \frac{1}{2} [S_\phi(f)] \quad (\text{per IEEE Std. 1139}),$$

and

$$\sigma_y^2(\tau) = \frac{2}{(\pi v \tau)^2} \int_0^\infty S_\phi(f) \sin^4(\pi f \tau) df$$

Where  $\tau$  = averaging time,  $v$  = carrier frequency, and  $f$  = offset or Fourier frequency, or “frequency from the carrier”.



# Allan Deviation

Also called **two-sample deviation**, or square-root of the "**Allan variance**," it is the standard method of describing the short term stability of oscillators in the time domain. It is denoted by  $\sigma_y(\tau)$ ,

where 
$$\sigma_y^2(\tau) = \frac{1}{2} \langle (y_{k+1} - y_k)^2 \rangle .$$

The fractional frequencies,  $y = \frac{\Delta f}{f}$  are measured over a time interval,  $\tau$ ;  $(y_{k+1} - y_k)$  are the differences between pairs of successive measurements of  $y$ , and, ideally,  $\langle \rangle$  denotes a time average of an infinite number of  $(y_{k+1} - y_k)^2$ . A good estimate can be obtained by a limited number,  $m$ , of measurements ( $m \geq 100$ ).  $\sigma_y(\tau)$  generally denotes  $\sqrt{\sigma_y^2(\tau, m)}$ , i.e.,

$$\sigma_y^2(\tau) = \sigma_y^2(\tau, m) = \frac{1}{m} \sum_{j=1}^m \frac{1}{2} (y_{k+1} - y_k)_j^2$$

# Why $\sigma_y(\tau)$ ?

- **Classical variance:**  $\sigma_{y_i}^2 = \frac{1}{m-1} \sum (y_i - \bar{y})^2,$

diverges for some commonly observed noise processes, such as random walk, i.e., the variance increases with increasing number of data points.

- **Allan variance:**
  - Converges for all noise processes observed in precision oscillators.
  - Has straightforward relationship to power law spectral density types.
  - Is easy to compute.
  - Is faster and more accurate in estimating noise processes than the Fast Fourier Transform.

# Frequency Noise and $\sigma_y(\tau)$

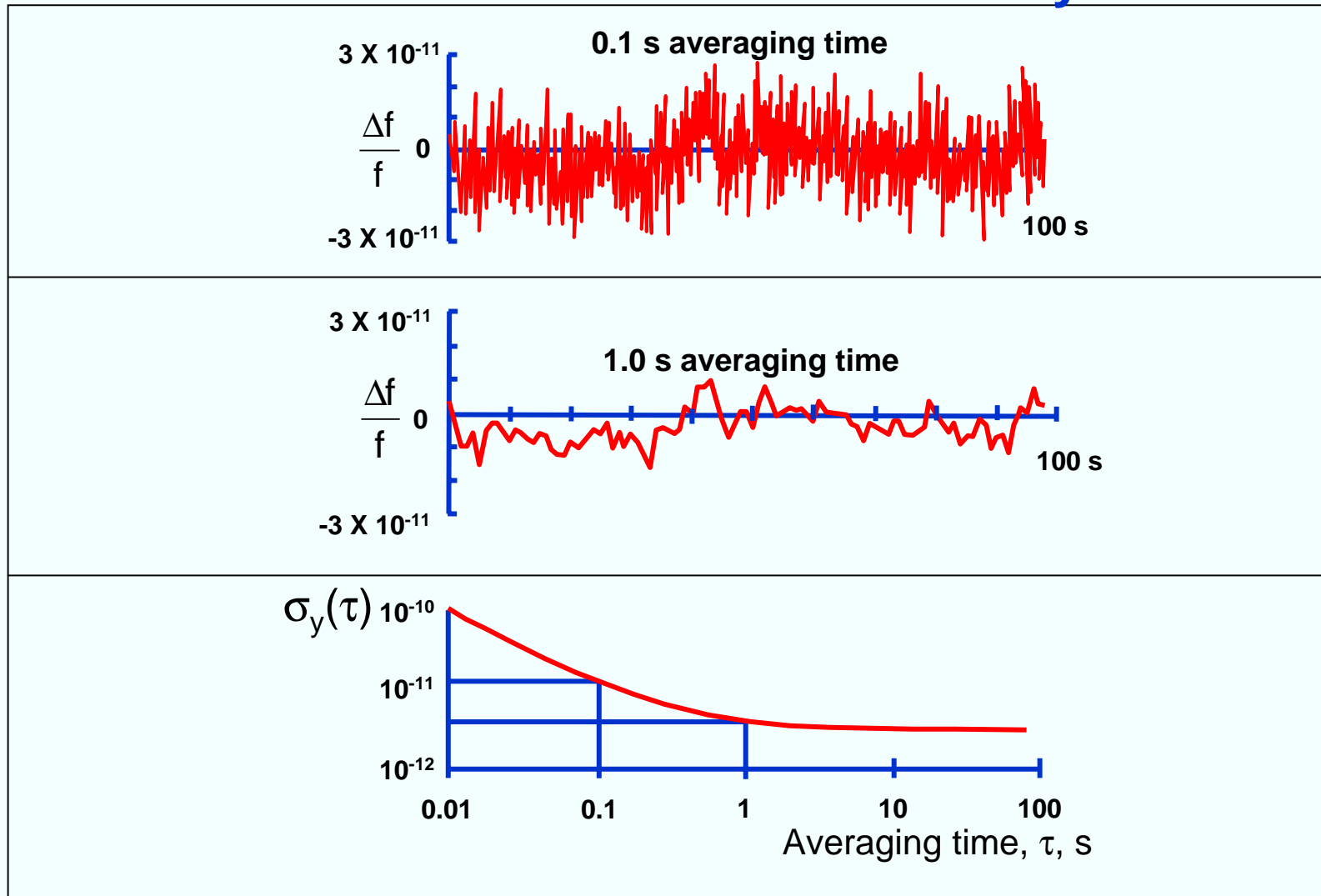

# Time Domain Stability

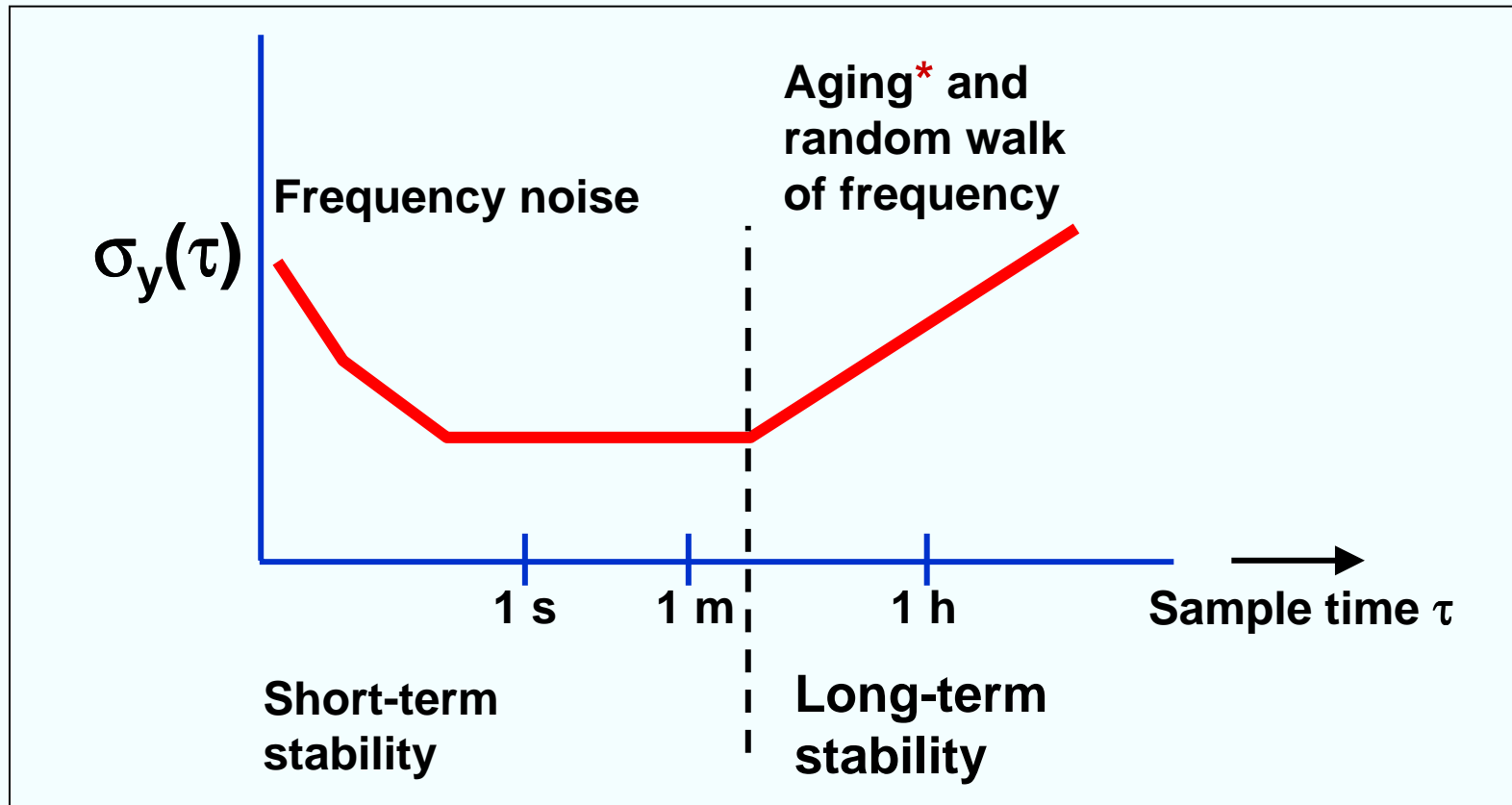

\*For  $\sigma_y(\tau)$  to be a proper measure of random frequency fluctuations, aging must be properly subtracted from the data at long  $\tau$ 's.

# Power Law Dependence of $\sigma_y(\tau)$

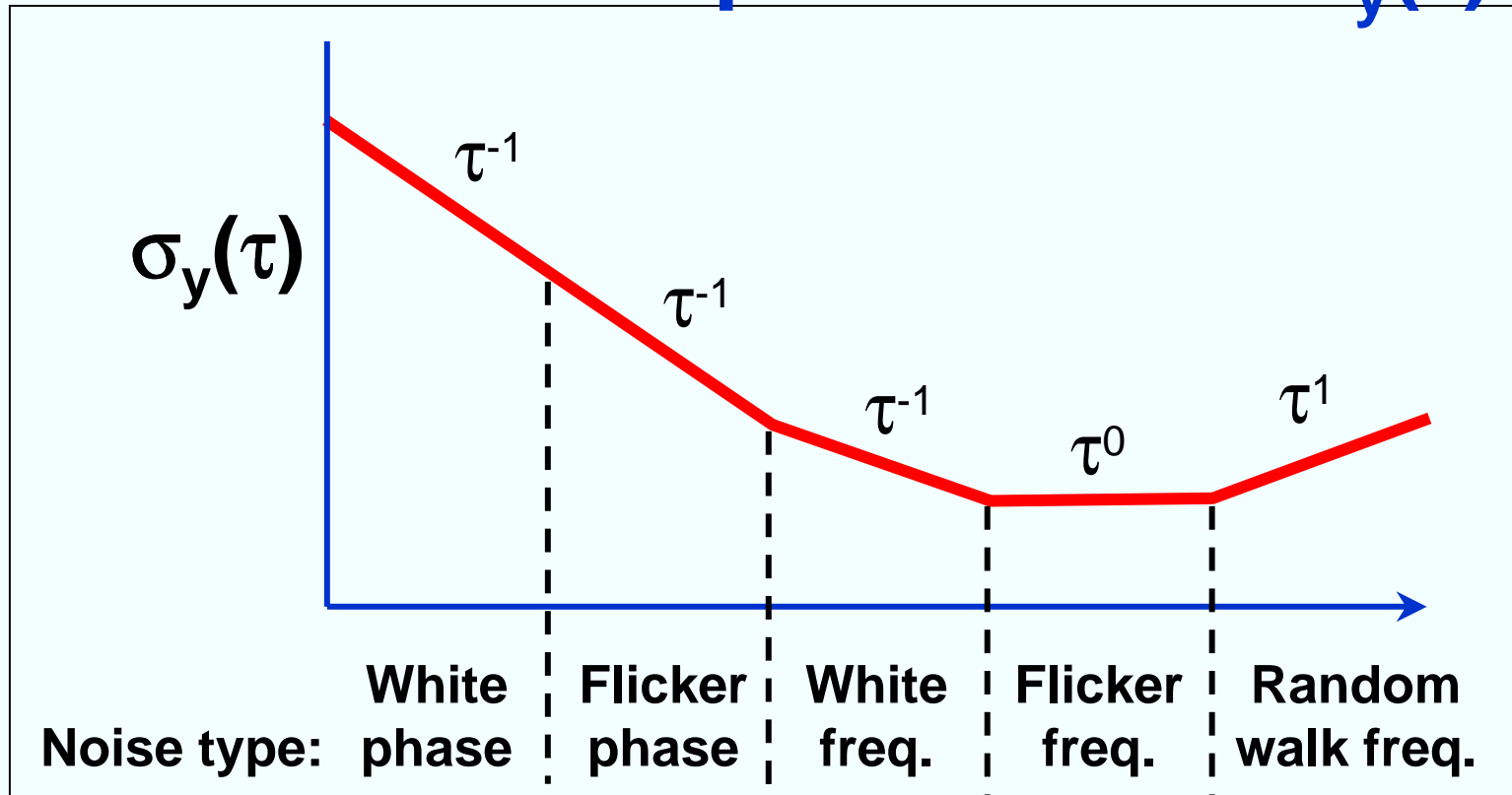

Below the flicker of frequency noise (i.e., the “flicker floor”) region, crystal oscillators typically show  $\tau^{-1}$  (white phase noise) dependence. Atomic standards show  $\tau^{-1/2}$  (white frequency noise) dependence down to about the servo-loop time constant, and  $\tau^{-1}$  dependence at less than that time constant. Typical  $\tau$ 's at the start of flicker floors are: 1 second for a crystal oscillator,  $10^3$ s for a Rb standard and  $10^5$ s for a Cs standard.

# Pictures of Noise

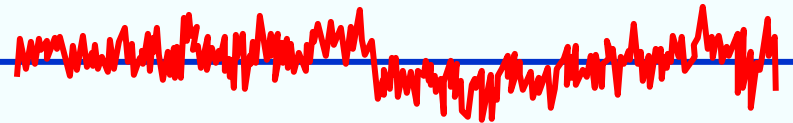
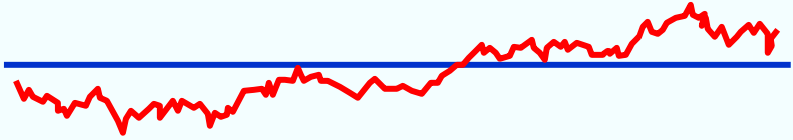
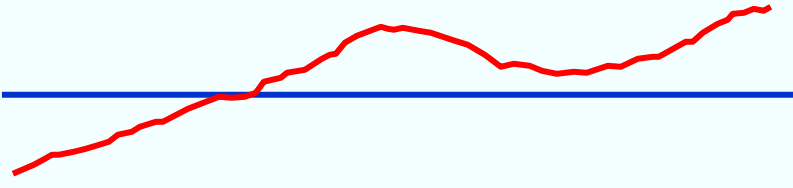
Plot of $z(t)$ vs. $t$	$S_z(f) = h_\alpha f^\alpha$	Noise name
	$\alpha = 0$	White
	$\alpha = -1$	Flicker
	$\alpha = -2$	Random walk
	$\alpha = -3$	

Plots show fluctuations of a quantity  $z(t)$ , which can be, e.g., the output of a counter ( $\Delta f$  vs.  $t$ ) or of a phase detector ( $\phi[t]$  vs.  $t$ ). The plots show simulated time-domain behaviors corresponding to the most common (power-law) spectral densities;  $h_\alpha$  is an amplitude coefficient. Note: since  $S_{\Delta f} = f^2 S_\phi$ , e.g. white frequency noise and random walk of phase are equivalent.

# Spectral Densities

$$V(t) = [V_0 + \varepsilon(t)] \sin [2\pi\nu_0 t + \phi(t)]$$

In the frequency domain, due to the phase deviation,  $\phi(t)$ , some of the power is at frequencies other than  $\nu_0$ . The stabilities are characterized by "spectral densities." The spectral density,  $S_V(f)$ , the mean-square voltage  $\langle V^2(t) \rangle$  in a unit bandwidth centered at  $f$ , is not a good measure of frequency stability because both  $\varepsilon(t)$  and  $\phi(t)$  contribute to it, and because it is not uniquely related to frequency fluctuations (although  $\varepsilon(t)$  is often negligible in precision frequency sources.)

The spectral densities of phase and fractional-frequency fluctuations,  $S_\phi(f)$  and  $S_y(f)$ , respectively, are used to measure the stabilities in the frequency domain. The spectral density  $S_g(f)$  of a quantity  $g(t)$  is the mean square value of  $g(t)$  in a unit bandwidth centered at  $f$ . Moreover, the RMS value of  $g^2$  in bandwidth BW is given by  $g_{\text{RMS}}^2(t) = \int_{\text{BW}} S_g(f) df$ .

# Mixer Functions

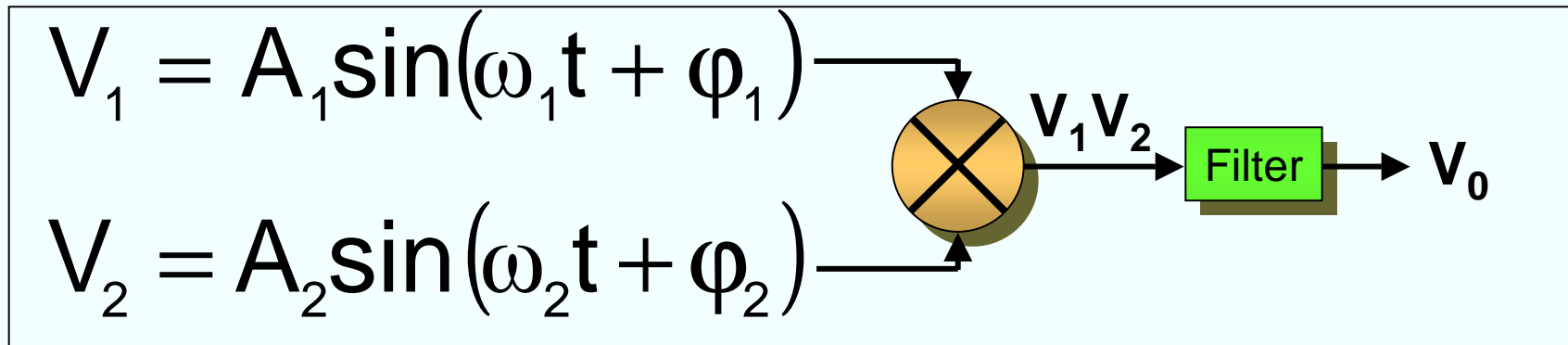

Trigonometric identities:  $\sin(x)\sin(y) = \frac{1}{2}\cos(x-y) - \frac{1}{2}\cos(x+y)$   
 $\cos(x \pm \pi/2) = \sin(x)$

Let  $\omega_1 = \omega_2$ ;  $\Phi_1 \equiv \omega_1 t + \phi_1$ , and  $\Phi_2 \equiv \omega_2 t + \phi_2$ . Then the mixer can become :

- **Phase detector:** When  $\Phi_1 = \Phi_2 + \pi/2$  and  $A_1 = A_2 = 1$ , then

$$V_0 = \frac{1}{2} \sin(\phi_1 - \phi_2) = \frac{1}{2} (\phi_1 - \phi_2) \text{ for small } \phi \text{'s}$$

- **AM detector:** When  $A_2 = 1$  and the filter is a low – pass filter, then

$$V_0 = \frac{1}{2} A_1 \cos(\phi_1 - \phi_2); \text{ if } \phi_1 \approx \phi_2, \text{ then } V_0 \approx \frac{1}{2} A_1$$

- **Frequency multiplier:** When  $V_1 = V_2$  and the filter is bandpass at  $2\omega_1$  then,  $V_0 = \frac{1}{2} A_1^2 \cos(2\omega_1 t + 2\phi_1) \Rightarrow$  doubles the frequency and phase error.



# Phase Detector

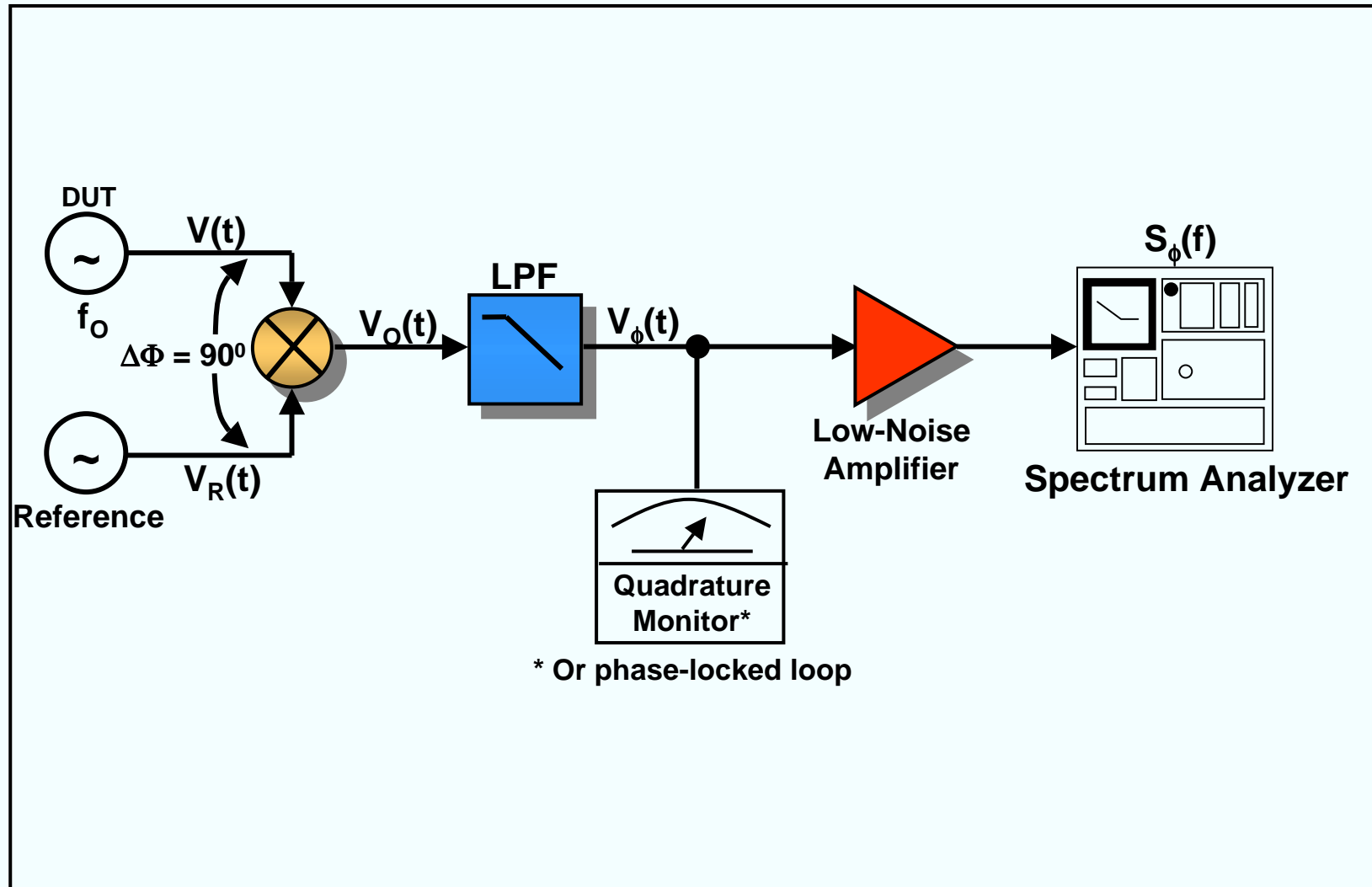

# Phase Noise Measurement

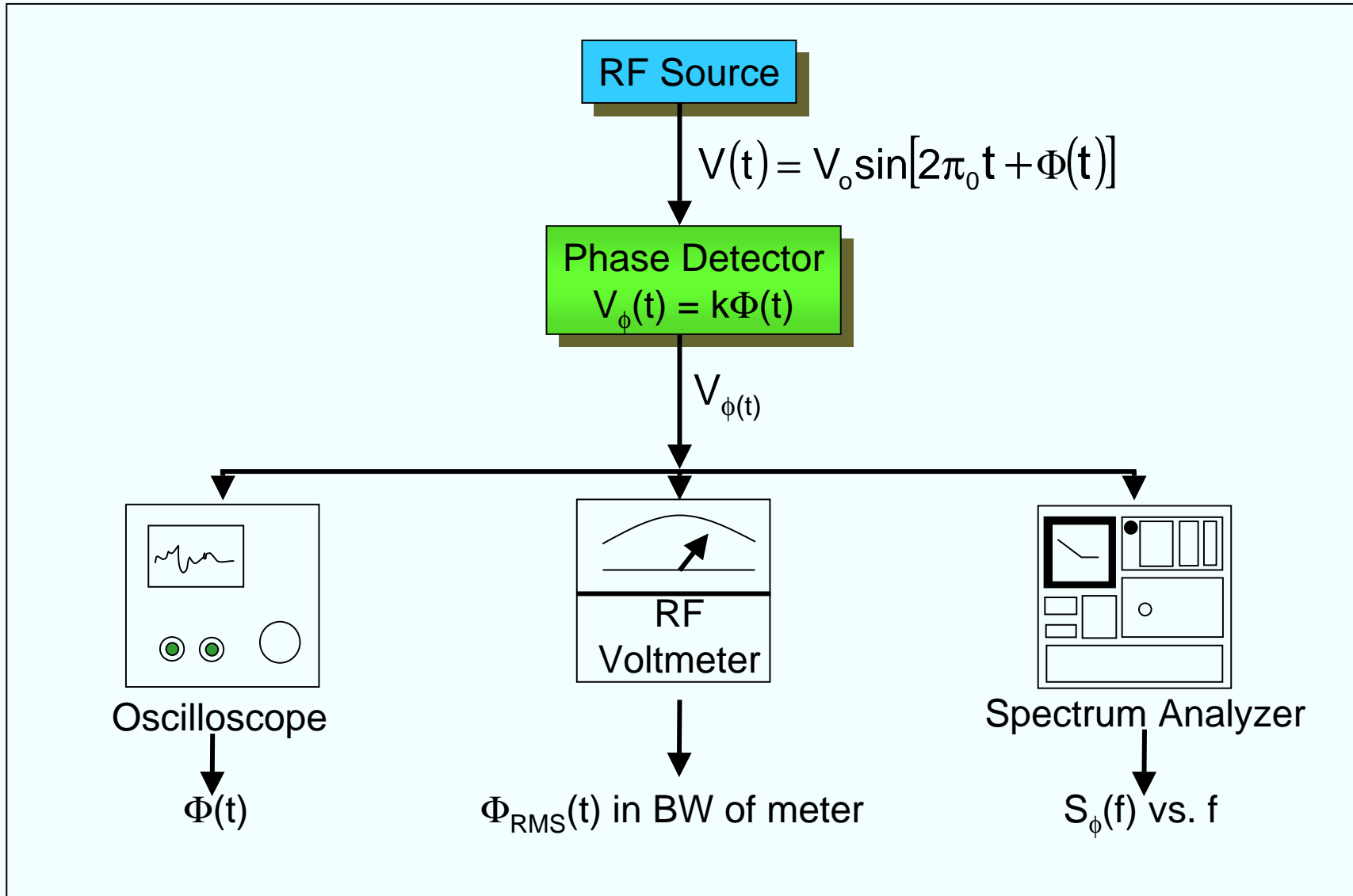

# Frequency - Phase - Time Relationships

$$v(t) = v_0 + \frac{1}{2\pi} \frac{d\phi(t)}{dt} = \text{"instantaneous" frequency}; \quad \phi(t) = \phi_0 + \int_0^t 2\pi[v(t') - v_0] dt'$$

$$y(t) \equiv \frac{v(t) - v_0}{v_0} = \frac{\dot{\phi}(t)}{2\pi v_0} = \text{normalized frequency}; \quad \phi_{\text{RMS}}^2 = \int S_\phi(f) dt$$

$$S_\phi(f) = \frac{\phi_{\text{RMS}}^2}{\text{BW}} = \left(\frac{v_0}{f}\right)^2 S_y(f); \quad L(f) \equiv 1/2 S_\phi(f), \text{ per IEEE Standard 1139 - 1988}$$

$$\sigma_y^2(\tau) = 1/2 \langle (\bar{y}_{k+1} - \bar{y}_k)^2 \rangle = \frac{2}{(\pi v_0 \tau)^2} \int_0^\infty S_\phi(f) \sin^4(\pi f \tau) df$$

The five common power-law noise processes in precision oscillators are:

$$S_y(f) = h_2 f^2 + h_1 f + h_0 + h_{-1} f^{-1} + h_{-2} f^{-2}$$

(White PM)    (Flicker PM)    (White FM)    (Flicker FM)    (Random-walk FM)

$$\text{Time deviation} = x(t) = \int_0^t y(t') dt' = \frac{\phi(t)}{2\pi v}$$

# $S_{\phi}(f)$ to SSB Power Ratio Relationship

Consider the “simple” case of sinusoidal phase modulation at frequency  $f_m$ . Then,  $\phi(t) = \phi_o(t)\sin(2\pi f_m t)$ , and  $V(t) = V_o \cos[2\pi f_c t + \phi(t)] = V_o \cos[2\pi f_c t + \phi_o(t)\sin(\pi f_m t)]$ , where  $\phi_o(t)$  = peak phase excursion, and  $f_c$  = carrier frequency. Cosine of a sine function suggests a Bessel function expansion of  $V(t)$  into its components at various frequencies via the identities:

$$\cos(X + Y) = \cos X \cos Y - \sin X \sin Y$$

$$\cos X \cos Y = 1/2[\cos(X + Y) + \cos(X - Y)]$$

$$-\sin X \sin Y = [\cos(X + Y) - \cos(X - Y)]$$

$$\cos(B \sin X) = J_0(B) + 2 \sum_{n=1}^{\infty} J_{2n}(B) \cos(2nX)$$

$$\sin(B \sin X) = 2 \sum_{n=0}^{\infty} J_{2n+1}(B) \sin[(2n+1)X]$$

After some messy algebra,  $S_V(f)$  and  $S_{\phi}(f)$  are as shown on the next page. Then,

$$\text{SSB Power Ratio at } f_m = \frac{V_o^2 J_1^2[\Phi(f_m)]}{V_o^2 J_0^2[\Phi(f_m)] + 2 \sum_{i=1}^{\infty} J_i^2[\Phi(f_m)]}$$

if  $\Phi(f_m) \ll 1$ , then  $J_0 = 1$ ,  $J_1 = 1/2\Phi(f_m)$ ,  $J_n = 0$  for  $n > 1$ , and

$$\text{SSB Power Ratio} = L(f_m) = \frac{\Phi^2(f_m)}{4} = \frac{S_{\phi}(f_m)}{2}$$

# $S_\phi(f)$ , $S_v(f)$ and $L(f)$

$$\Phi(t) = \Phi(f_m) \cos(2\pi f_m t)$$

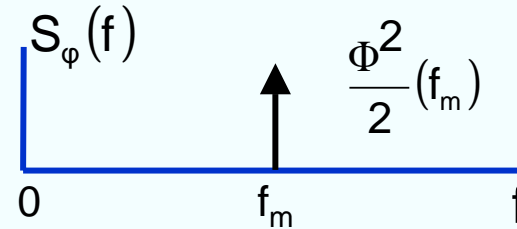

$$V(t) = V_0 \cos[2\pi f_c t + \Phi(f_m)]$$

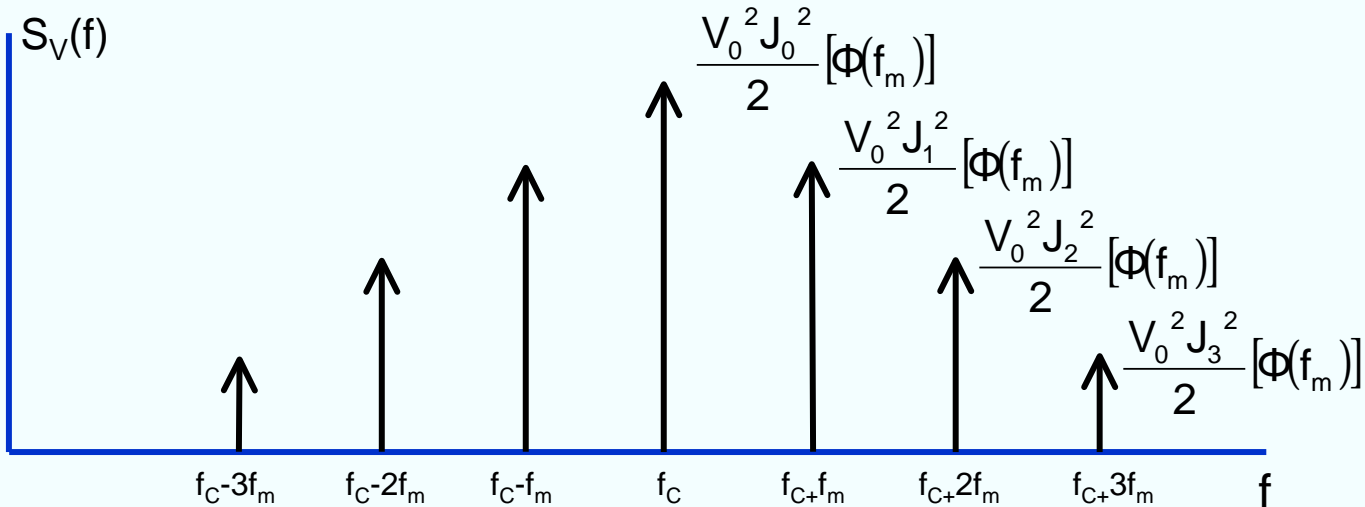

$$\text{SSB Power Ratio} = \frac{V_0^2 J_1^2 [\Phi(f_m)]}{V_0^2 J_0^2 [\Phi(f_m)] + 2 \sum_{i=1}^{\infty} J_i^2 [\Phi(f_m)]} \cong L(f_m) \cong \frac{S_\phi(f_m)}{2}$$

# Types of Phase Noise

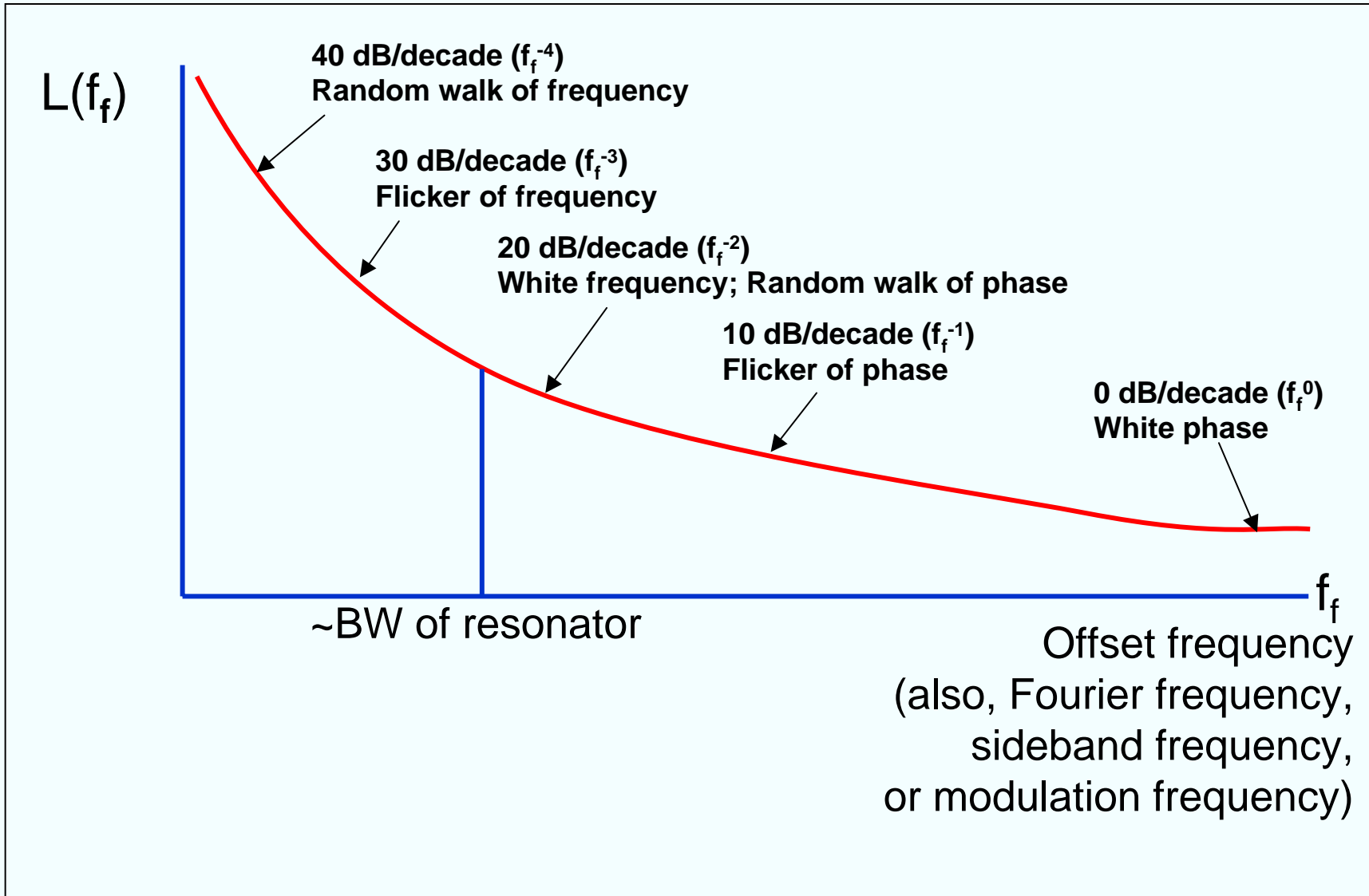

# Noise in Crystal Oscillators

- The resonator is the primary noise source close to the carrier; the oscillator sustaining circuitry is the primary source far from the carrier.
- Frequency multiplication by  $N$  increases the phase noise by  $N^2$  (i.e., by  $20\log N$ , in dB's).
- Vibration-induced "noise" dominates all other sources of noise in many applications (see acceleration effects section, later).
- Close to the carrier (within BW of resonator),  $S_y(f)$  varies as  $1/f$ ,  $S_\phi(f)$  as  $1/f^3$ , where  $f =$  offset from carrier frequency,  $\nu$ .  $S_\phi(f)$  also varies as  $1/Q^4$ , where  $Q =$  unloaded  $Q$ . Since  $Q_{\max}\nu = \text{const.}$ ,  $S_\phi(f) \propto \nu^4$ .  $(Q_{\max}\nu)_{\text{BAW}} = 1.6 \times 10^{13} \text{ Hz}$ ;  $(Q_{\max}\nu)_{\text{SAW}} = 1.05 \times 10^{13} \text{ Hz}$ .
- In the time domain, noise floor is  $\sigma_y(\tau) \geq (2.0 \times 10^{-7})Q^{-1} \approx 1.2 \times 10^{-20}\nu$ ,  $\nu$  in Hz. In the regions where  $\sigma_y(\tau)$  varies as  $\tau^{-1}$  and  $\tau^{-1/2}$  ( $\tau^{-1/2}$  occurs in atomic frequency standards),  $\sigma_y(\tau) \propto (QS_R)^{-1}$ , where  $S_R$  is the signal-to-noise ratio; i.e., the higher the  $Q$  and the signal-to-noise ratio, the better the short term stability (and the phase noise far from the carrier, in the frequency domain).
- It is the loaded  $Q$  of the resonator that affects the noise when the oscillator sustaining circuitry is a significant noise source.
- Noise floor is limited by Johnson noise; noise power,  $kT = -174 \text{ dBm/Hz}$  at  $290^\circ\text{K}$ .
- Higher signal level improves the noise floor but not the close-in noise. (In fact, high drive levels generally degrade the close-in noise, for reasons that are not fully understood.)
- Low noise SAW vs. low noise BAW multiplied up: BAW is lower noise at  $f < \sim 1 \text{ kHz}$ , SAW is lower noise at  $f > \sim 1 \text{ kHz}$ ; can phase lock the two to get the best of both.

# Low-Noise SAW and BAW Multiplied to 10 GHz (in a nonvibrating environment)

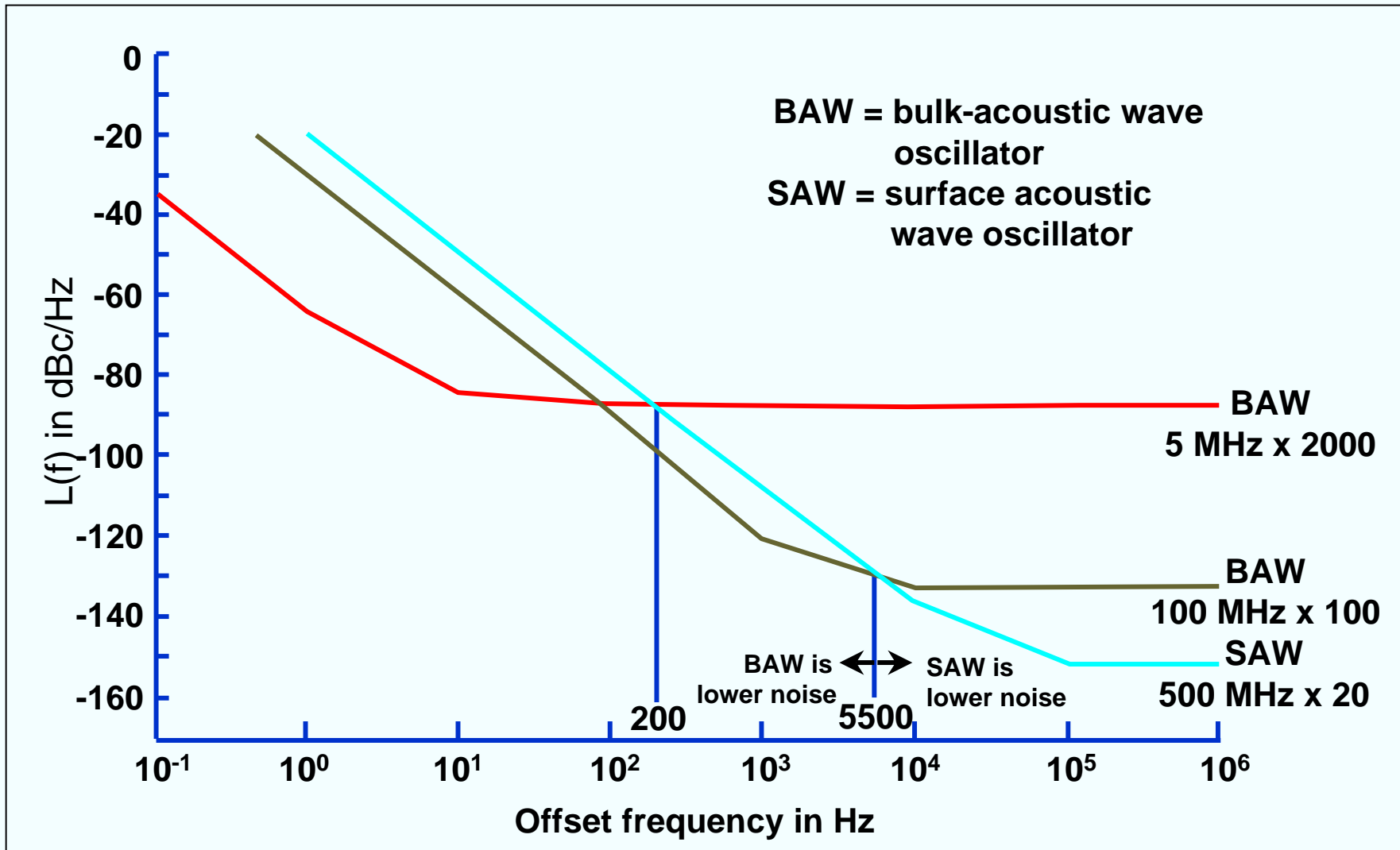



# Low-Noise SAW and BAW Multiplied to 10 GHz (in a vibrating environment)

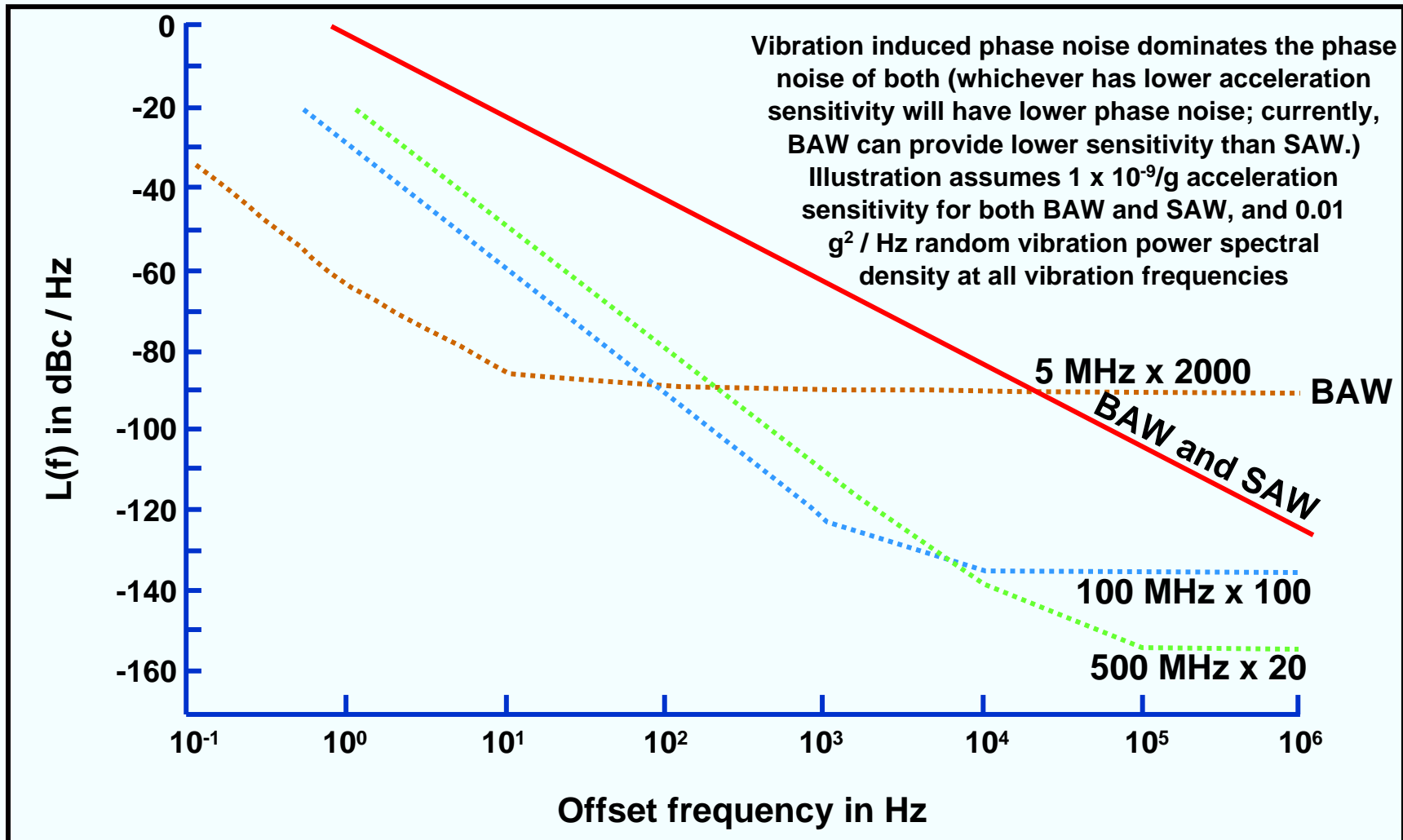

# Effects of Frequency Multiplication

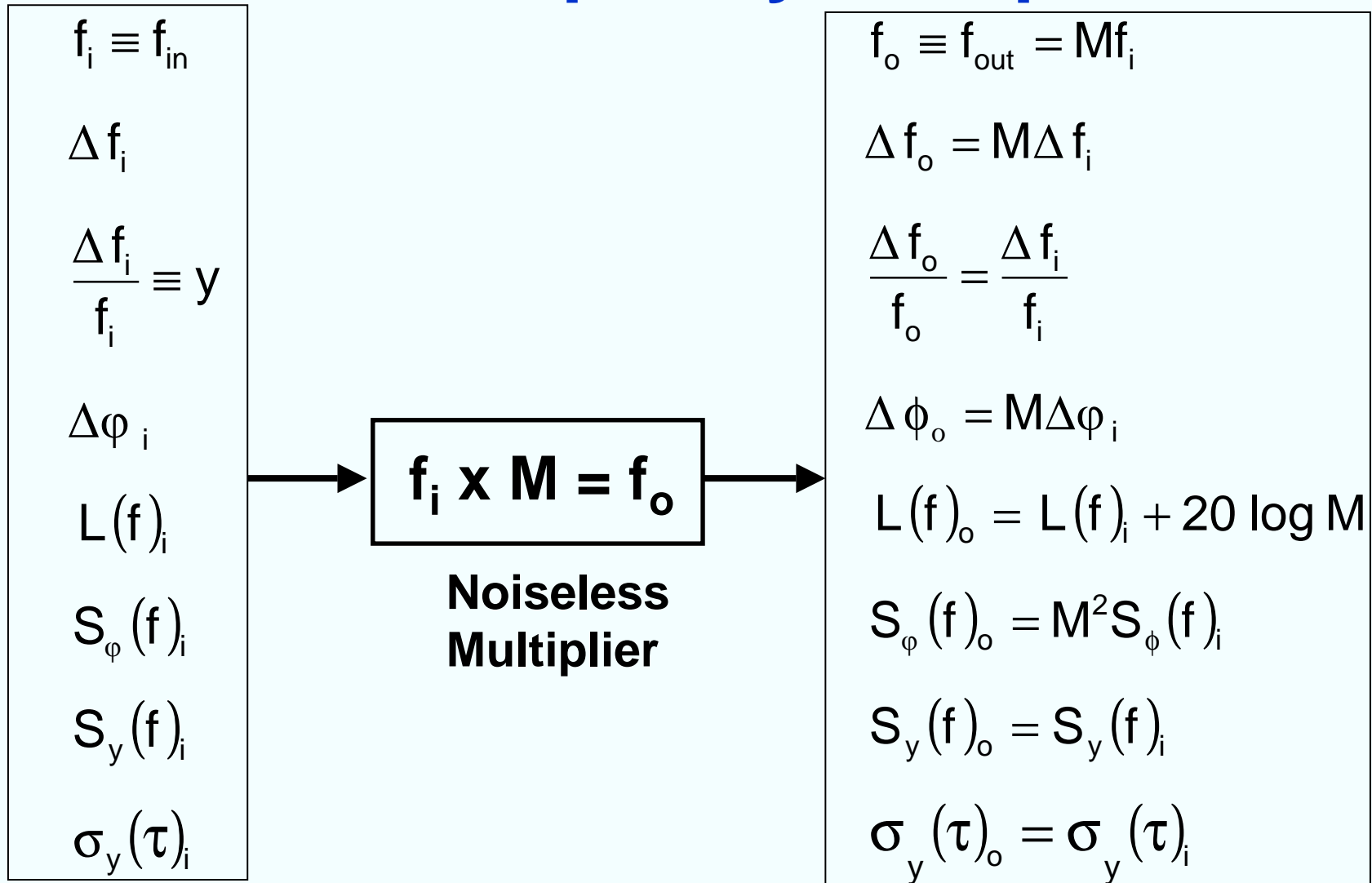

Note that  $y = \frac{\Delta f}{f}$ ,  $S_y(f)$ , and  $\sigma_y(\tau)$  are unaffected by frequency multiplication.

# TCXO Noise

The short term stabilities of TCXOs are temperature (T) dependent, and are generally worse than those of OCXOs, for the following reasons:

- The slope of the TCXO crystal's frequency (f) vs. T varies with T. For example, the f vs. T slope may be near zero at  $\sim 20^{\circ}\text{C}$ , but it will be  $\sim 1\text{ppm}/^{\circ}\text{C}$  at the T extremes. T fluctuations will cause small f fluctuations at laboratory ambient T's, so the stability can be good there, but millidegree fluctuations will cause  $\sim 10^{-9}$  f fluctuations at the T extremes. The TCXO's f vs. T slopes also vary with T; the zeros and maxima can be at any T, and the maximum slopes can be on the order of 1 ppm/ $^{\circ}\text{C}$ .
- AT-cut crystals' thermal transient sensitivity makes the effects of T fluctuations depend not only on the T but also on the rate of change of T (whereas the SC-cut crystals typically used in precision OCXOs are insensitive to thermal transients). Under changing T conditions, the T gradient between the T sensor (thermistor) and the crystal will aggravate the problems.
- TCXOs typically use fundamental mode AT-cut crystals which have lower Q and larger  $C_1$  than the crystals typically used in OCXOs. The lower Q makes the crystals inherently noisier, and the larger  $C_1$  makes the oscillators more susceptible to circuitry noise.
- AT-cut crystals' f vs. T often exhibit activity dips (see "Activity Dips" later in this chapter). At the T's where the dips occur, the f vs. T slope can be very high, so the noise due to T fluctuations will also be very high, e.g., 100x degradation of  $\sigma_y(\tau)$  and 30 dB degradation of phase noise are possible. Activity dips can occur at any T.

# Quartz Wristwatch Accuracy vs. Temperature

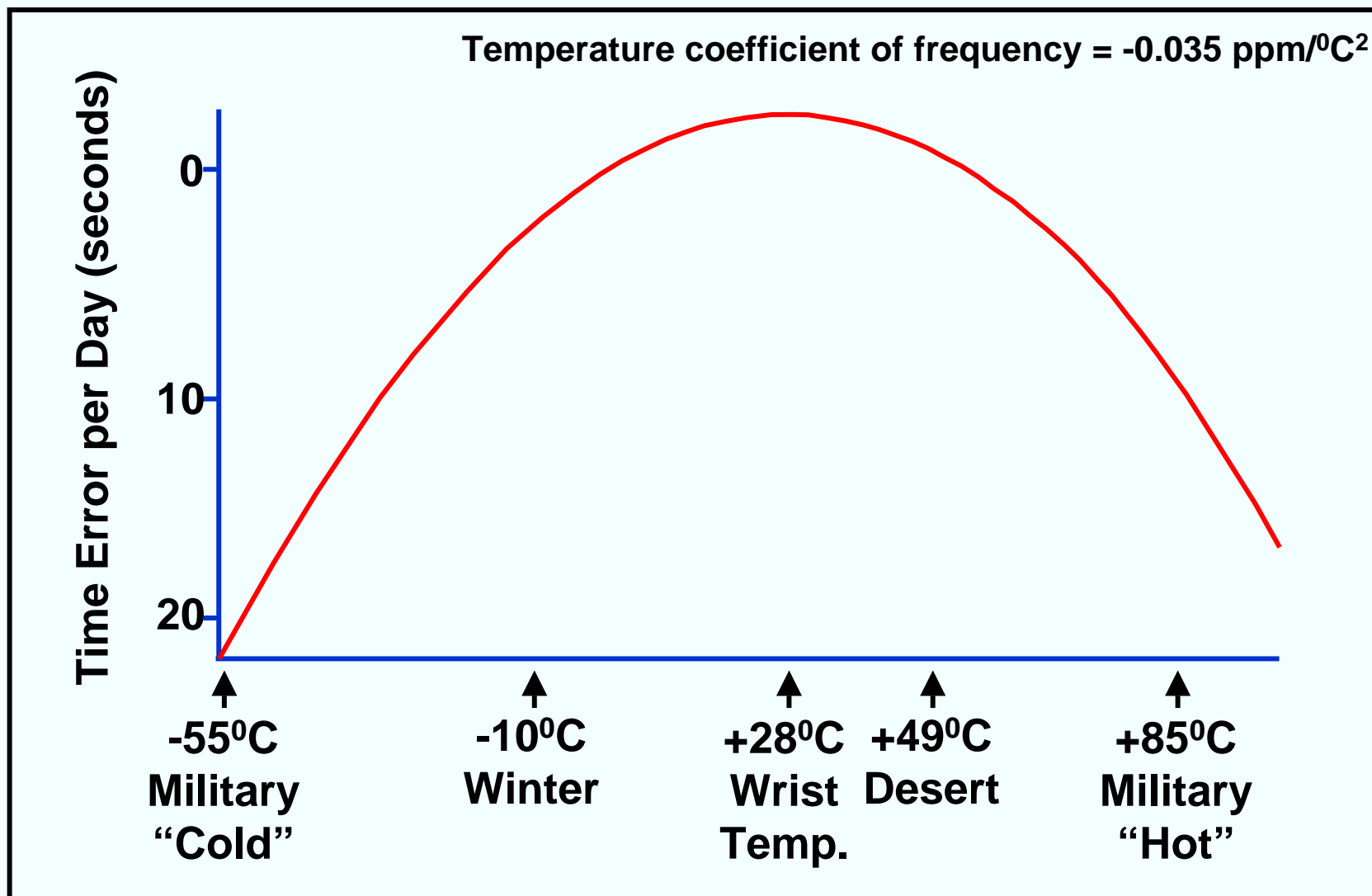

# Frequency vs. Temperature Characteristics

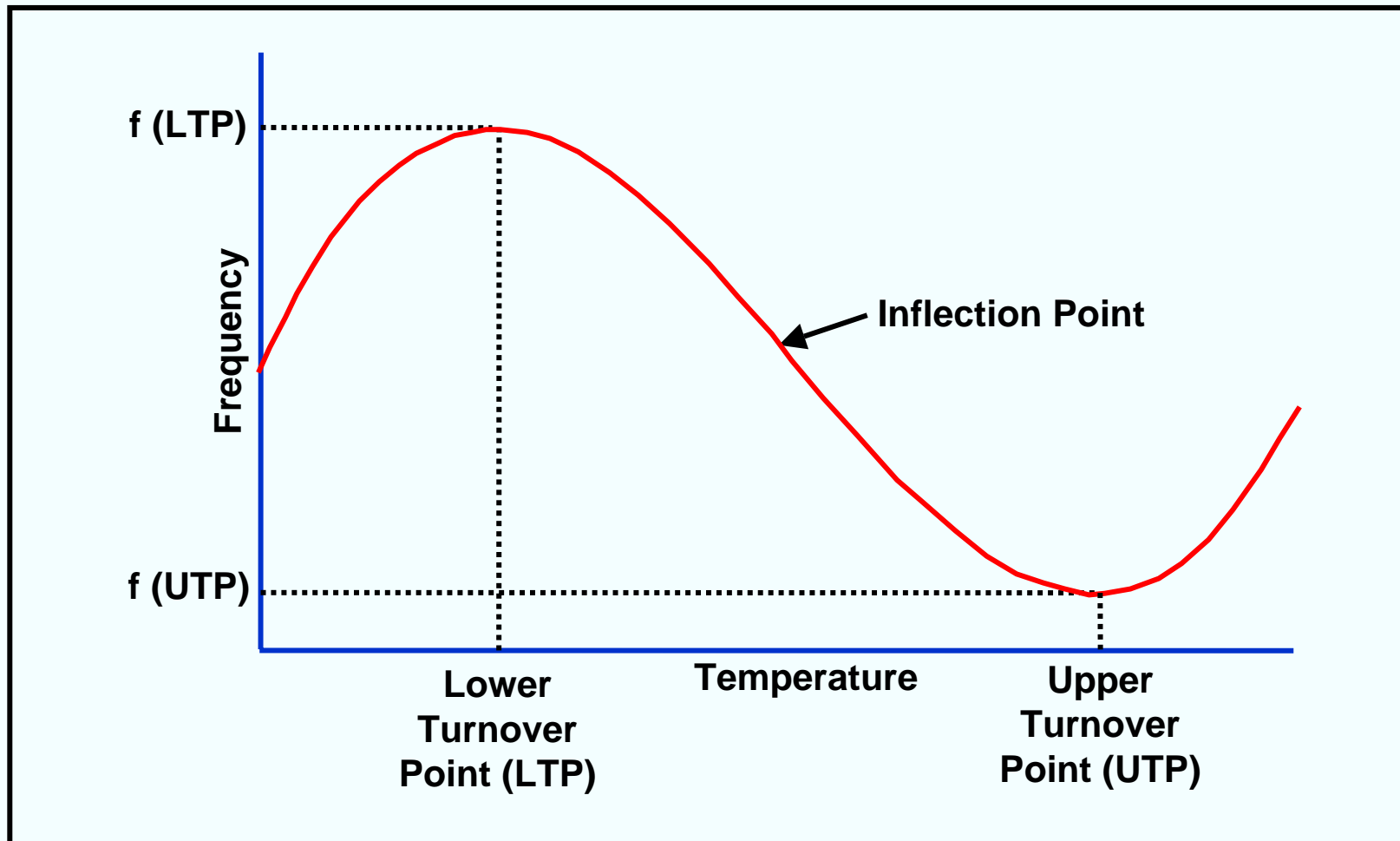

# Resonator $f$ vs. $T$ Determining Factors

- **Primary:** Angles of cut
- **Secondary:**
  - Overtone
  - Blank geometry (contour, dimensional ratios)
  - Material impurities and strains
  - Mounting & bonding stresses (magnitude and direction)
  - Electrodes (size, shape, thickness, density, stress)
  - Drive level
  - Interfering modes
  - Load reactance (value & temperature coefficient)
  - Temperature rate of change
  - Thermal history
  - Ionizing radiation

# Frequency-Temperature vs. Angle-of-Cut, AT-cut

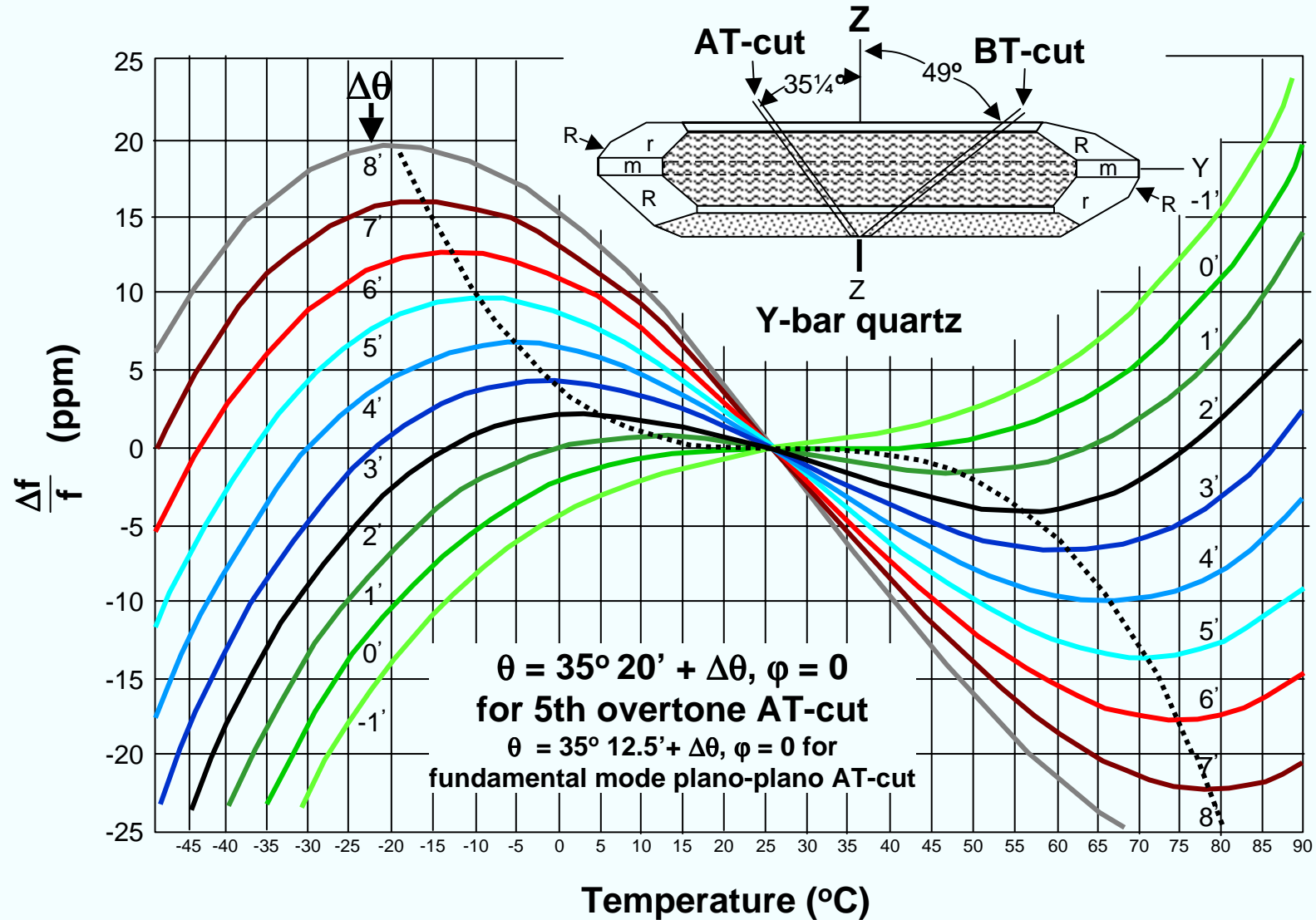

# Desired f vs. T of SC-cut Resonator for OCXO Applications

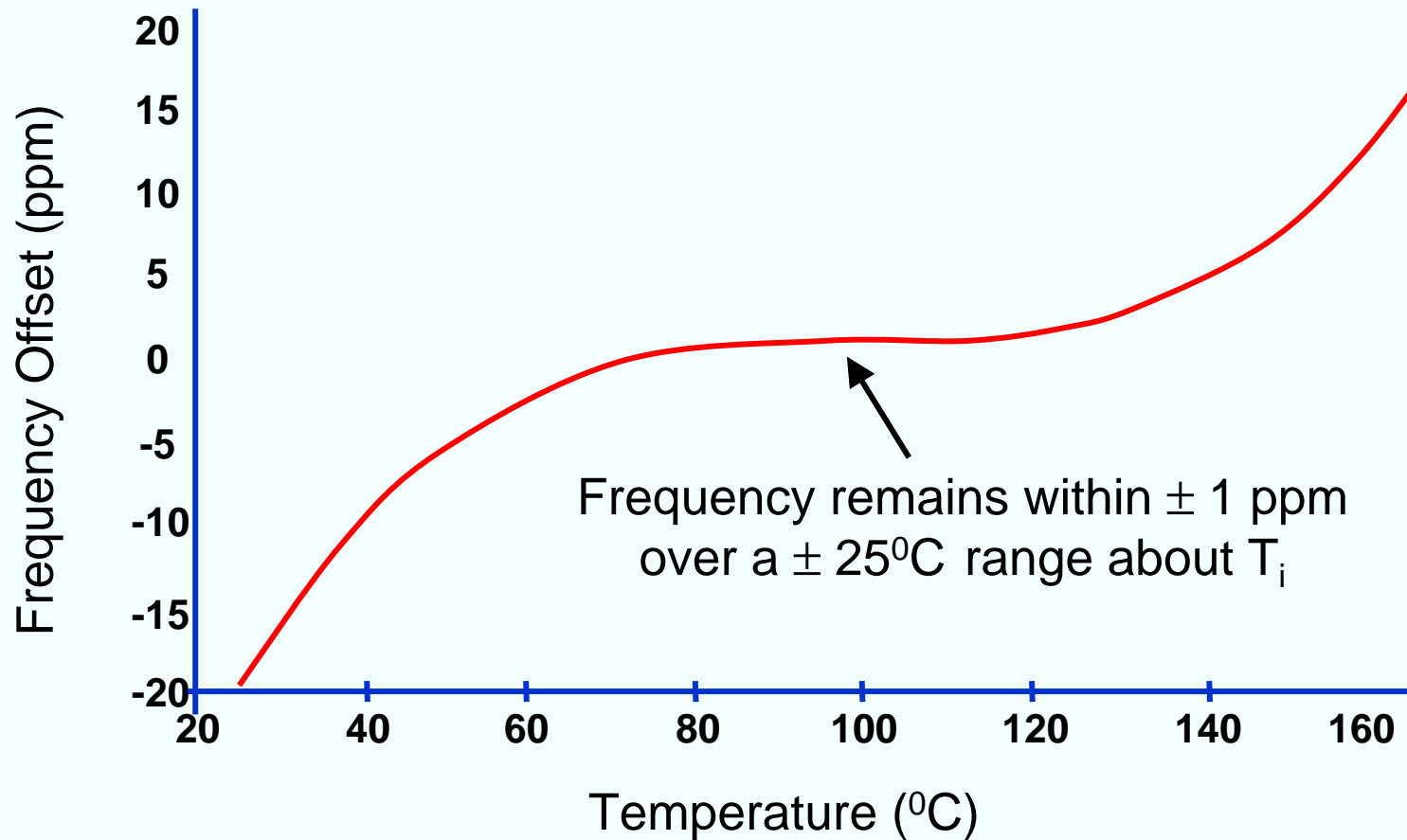



# OCXO Oven's Effect on Stability

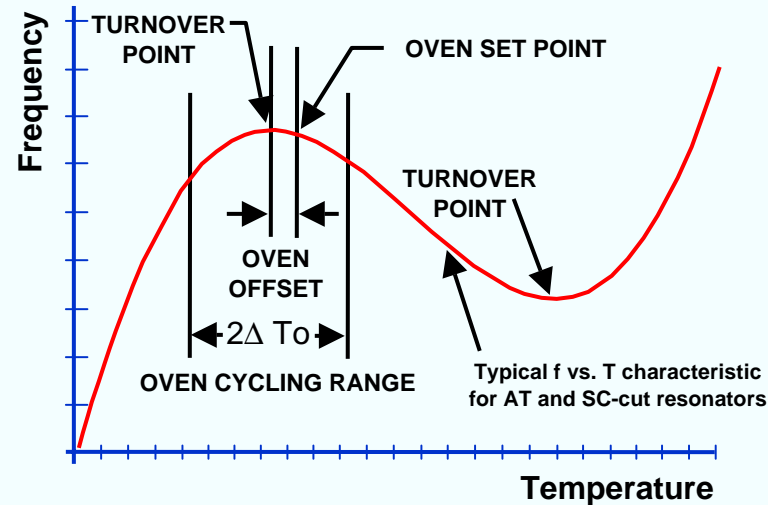

Oven Parameters vs. Stability for SC-cut Oscillator  
Assuming  $T_i - T_{LTP} = 10^{\circ}\text{C}$

$T_i - T_{LTP} = 10^{\circ}\text{C}$		Oven Cycling Range (millidegrees)			
		10	1	0.1	0.01
Oven Offset (millidegrees)	100	$4 \times 10^{-12}$	$4 \times 10^{-13}$	$4 \times 10^{-14}$	$4 \times 10^{-15}$
	10	$6 \times 10^{-13}$	$4 \times 10^{-14}$	$4 \times 10^{-15}$	$4 \times 10^{-16}$
	1	$2 \times 10^{-13}$	$6 \times 10^{-15}$	$4 \times 10^{-16}$	$4 \times 10^{-17}$
	0.1	$2 \times 10^{-13}$	$2 \times 10^{-15}$	$6 \times 10^{-17}$	$4 \times 10^{-18}$
	0	$2 \times 10^{-13}$	$2 \times 10^{-15}$	$2 \times 10^{-17}$	$2 \times 10^{-19}$

A comparative table for AT and other non-thermal-transient compensated cuts of oscillators would not be meaningful because the dynamic f vs. T effects would generally dominate the static f vs. T effects.

# Oven Stability Limits

- Thermal gain of  $10^5$  has been achieved with a feed-forward compensation technique (i.e., measure outside T of case & adjust setpoint of the thermistor to anticipate and compensate). For example, with a  $10^5$  gain, if outside  $\Delta T = 100^\circ\text{C}$ , inside  $\Delta T = 1 \text{ mK}$ .
- Stability of a good amplifier  $\sim 1\mu\text{K/K}$
- Stability of thermistors  $\sim 1\text{mK/year}$  to  $100\text{mK/year}$
- Noise  $< 1\mu\text{K}$  (Johnson noise in thermistor + amplifier noise + shot noise in the bridge current)
- Quantum limit of temperature fluctuations  $\sim 1\text{nK}$
- Optimum oven design can provide very high f vs. T stability

# Warmup of AT- and SC-cut Resonators

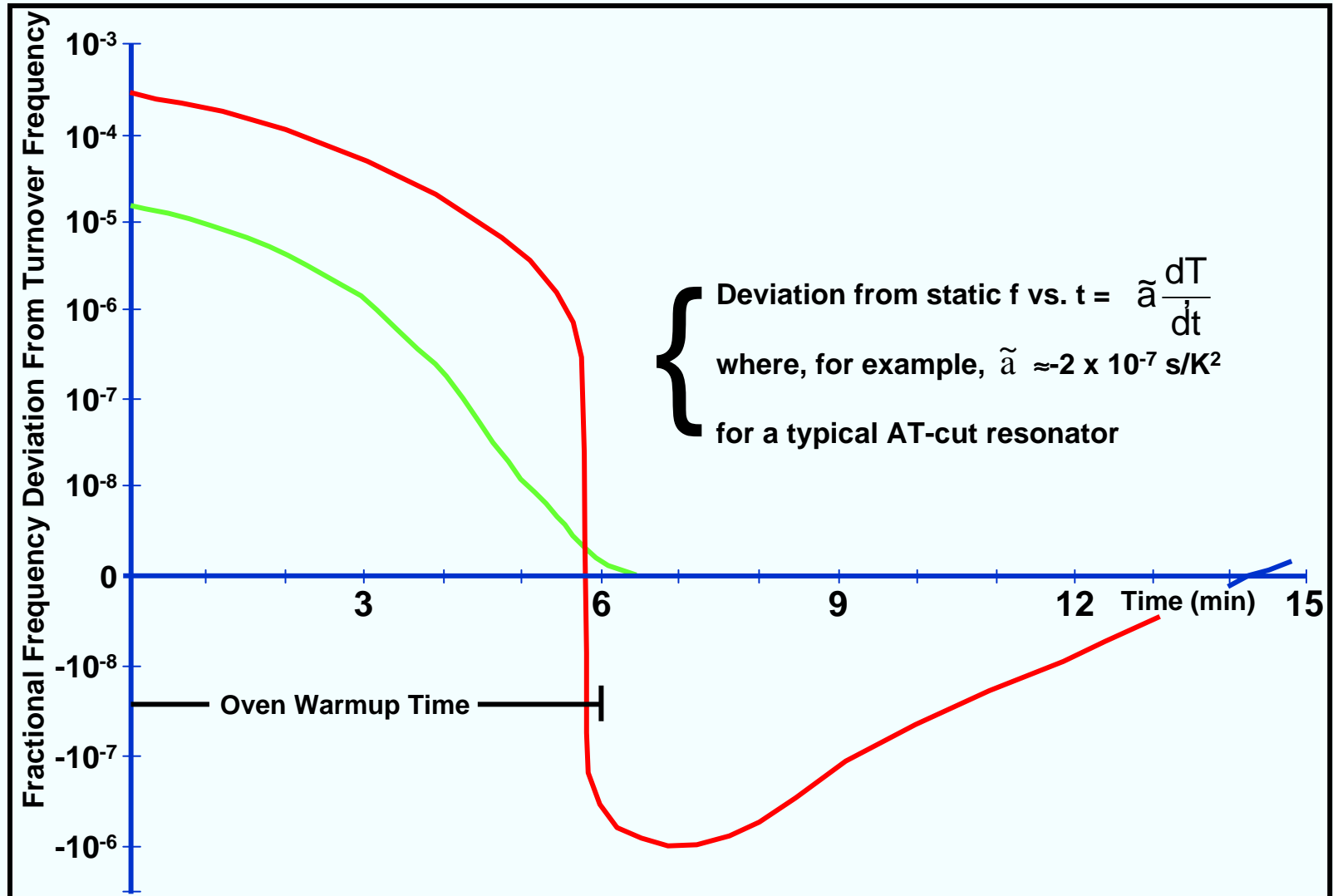

# TCXO Thermal Hysteresis

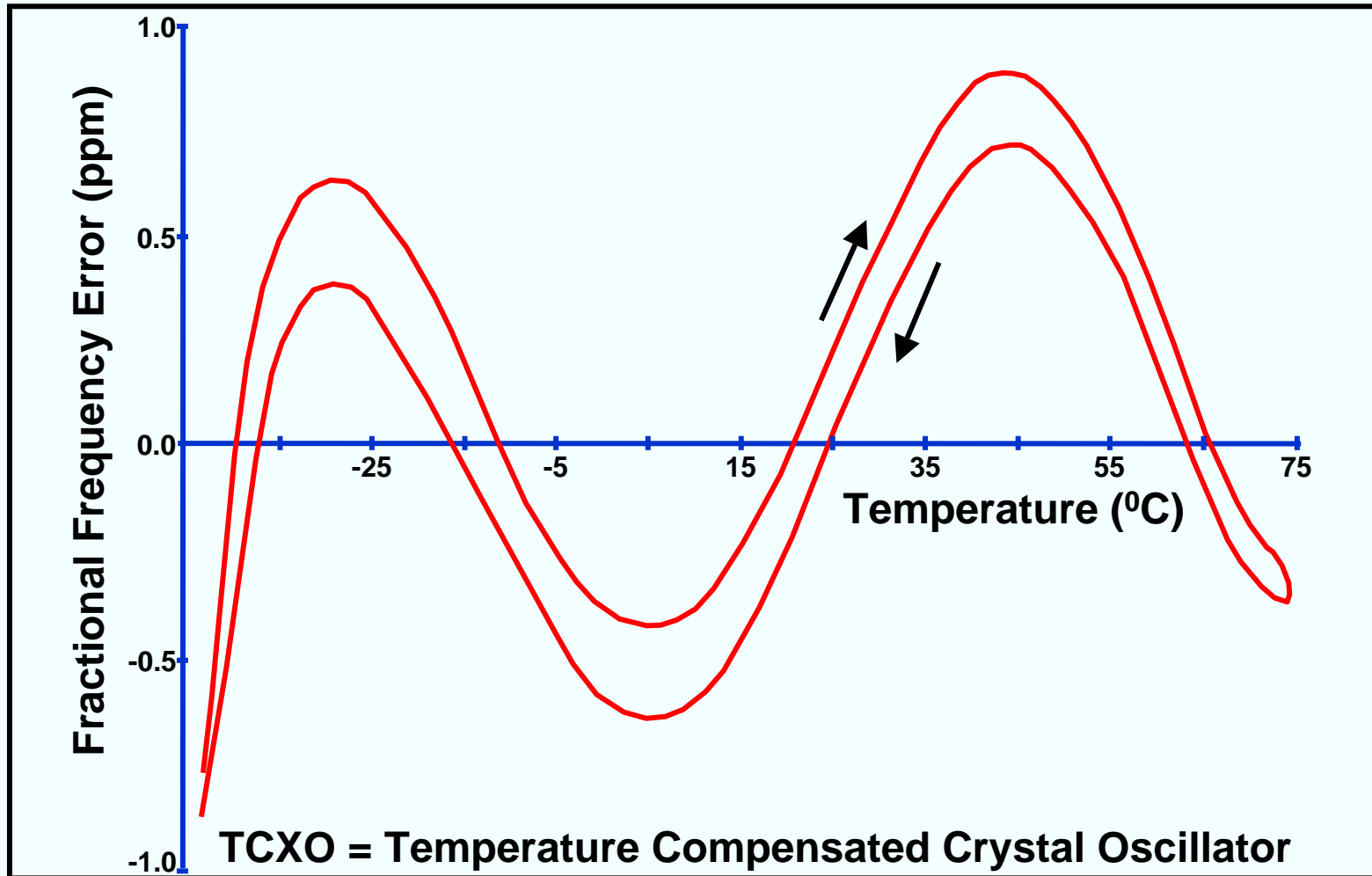

# Apparent Hysteresis

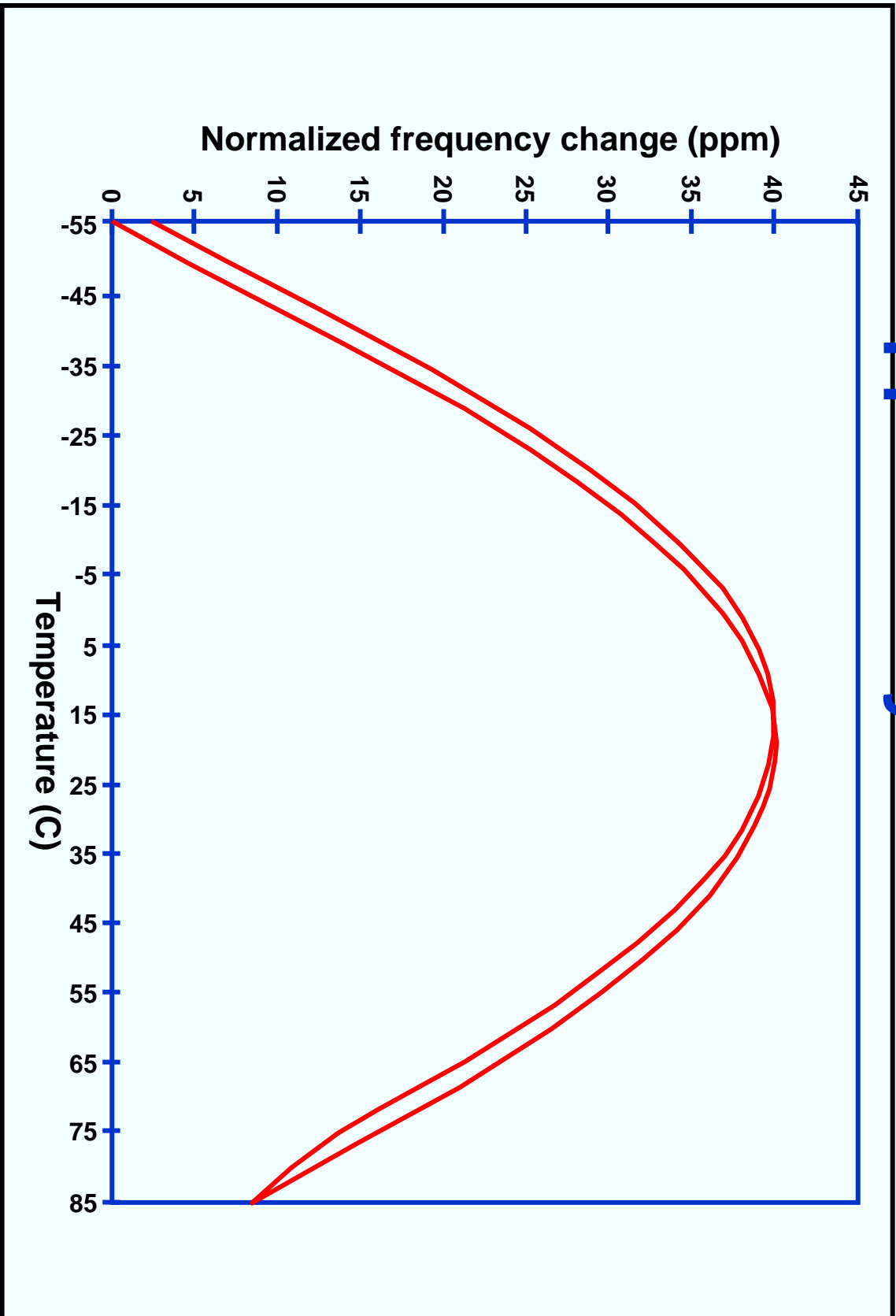

# OCXO Retrace

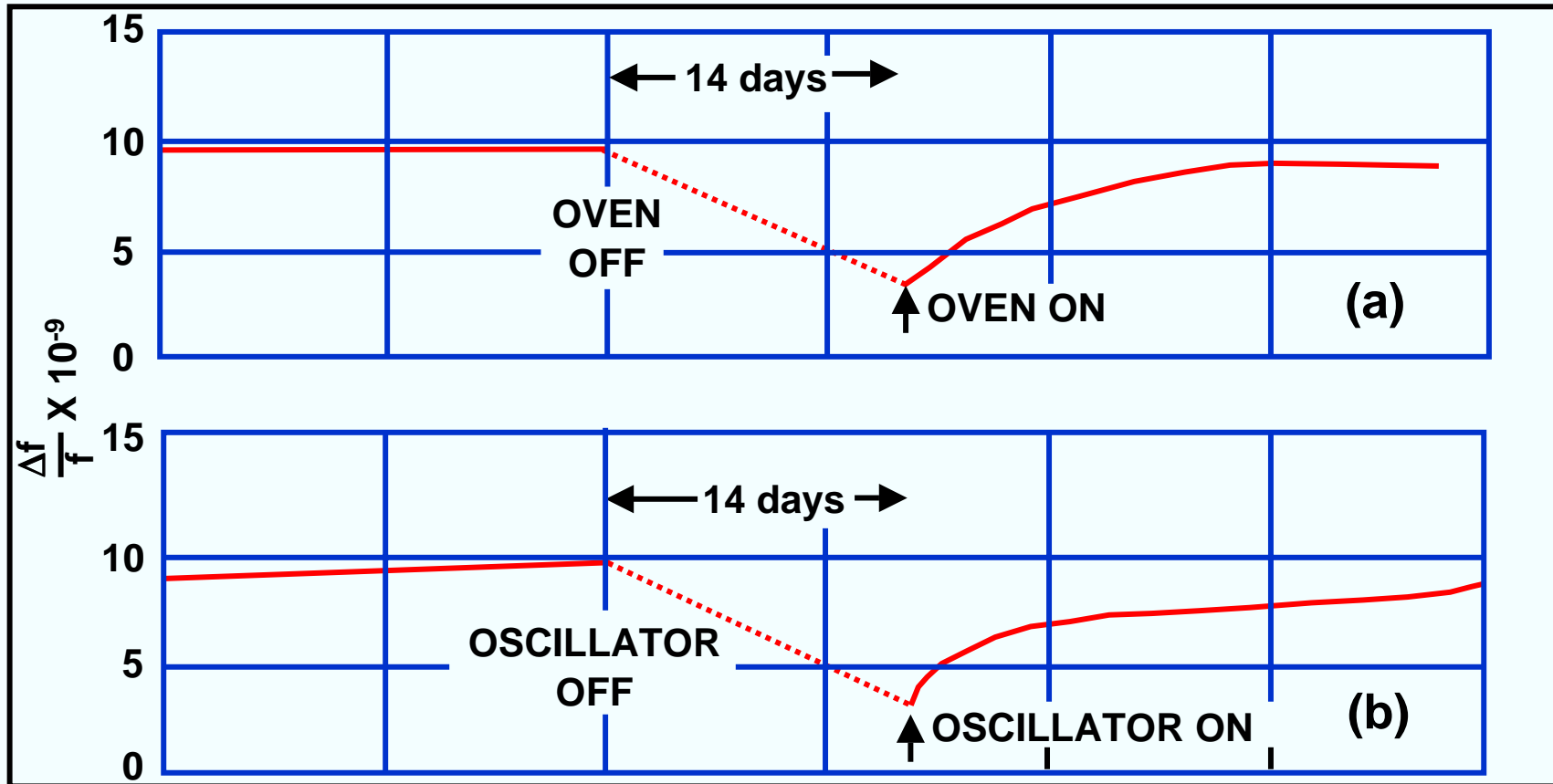

In (a), the oscillator was kept on continuously while the oven was cycled off and on. In (b), the oven was kept on continuously while the oscillator was cycled off and on.

# TCXO Trim Effect

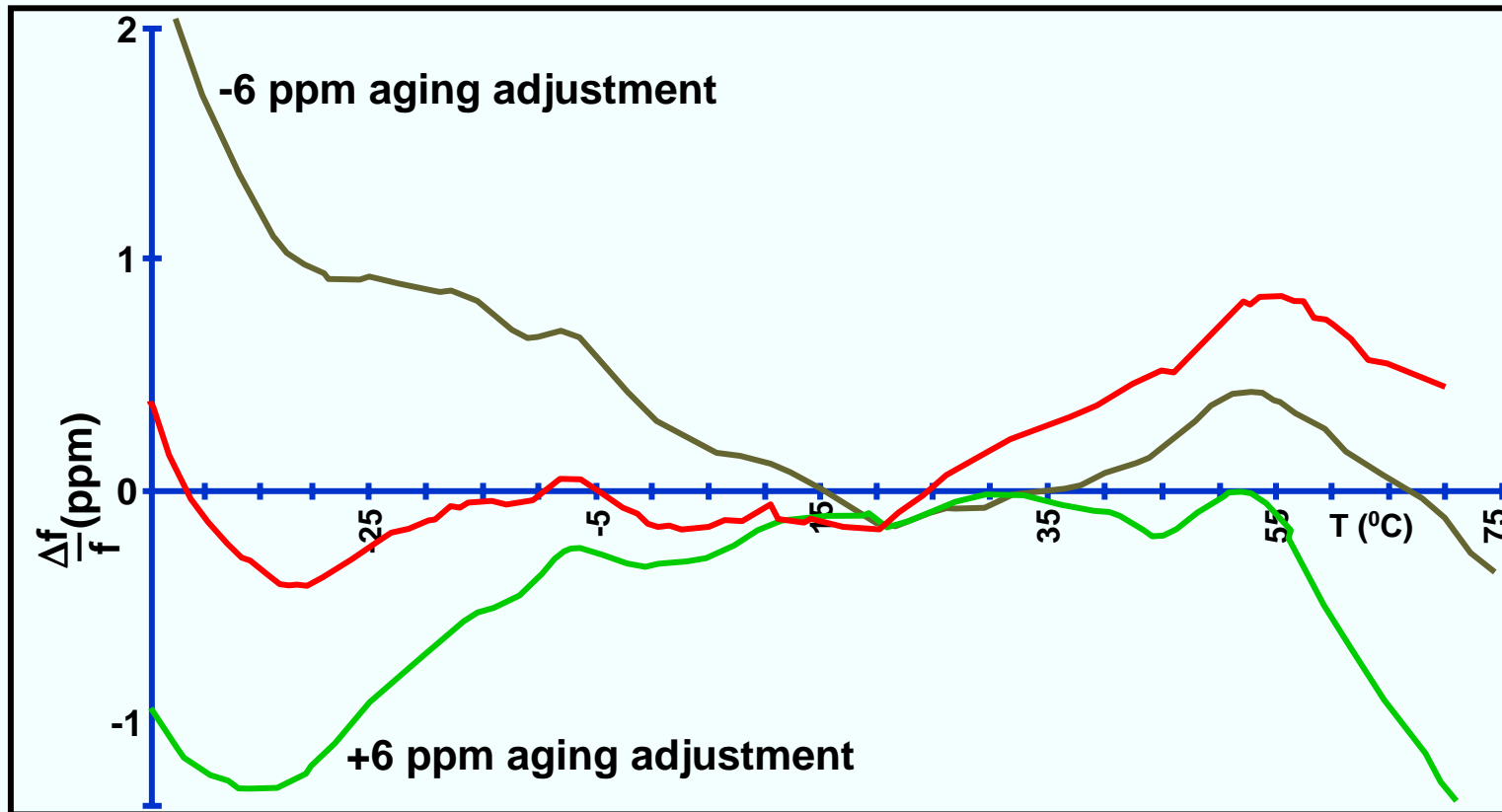

In TCXO's, temperature sensitive reactances are used to compensate for  $f$  vs.  $T$  variations. A variable reactance is also used to compensate for TCXO aging. The effect of the adjustment for aging on  $f$  vs.  $T$  stability is the "trim effect". Curves show  $f$  vs.  $T$  stability of a "0.5 ppm TCXO," at zero trim and at  $\pm 6$  ppm trim. (Curves have been vertically displaced for clarity.)

# Why the Trim Effect?

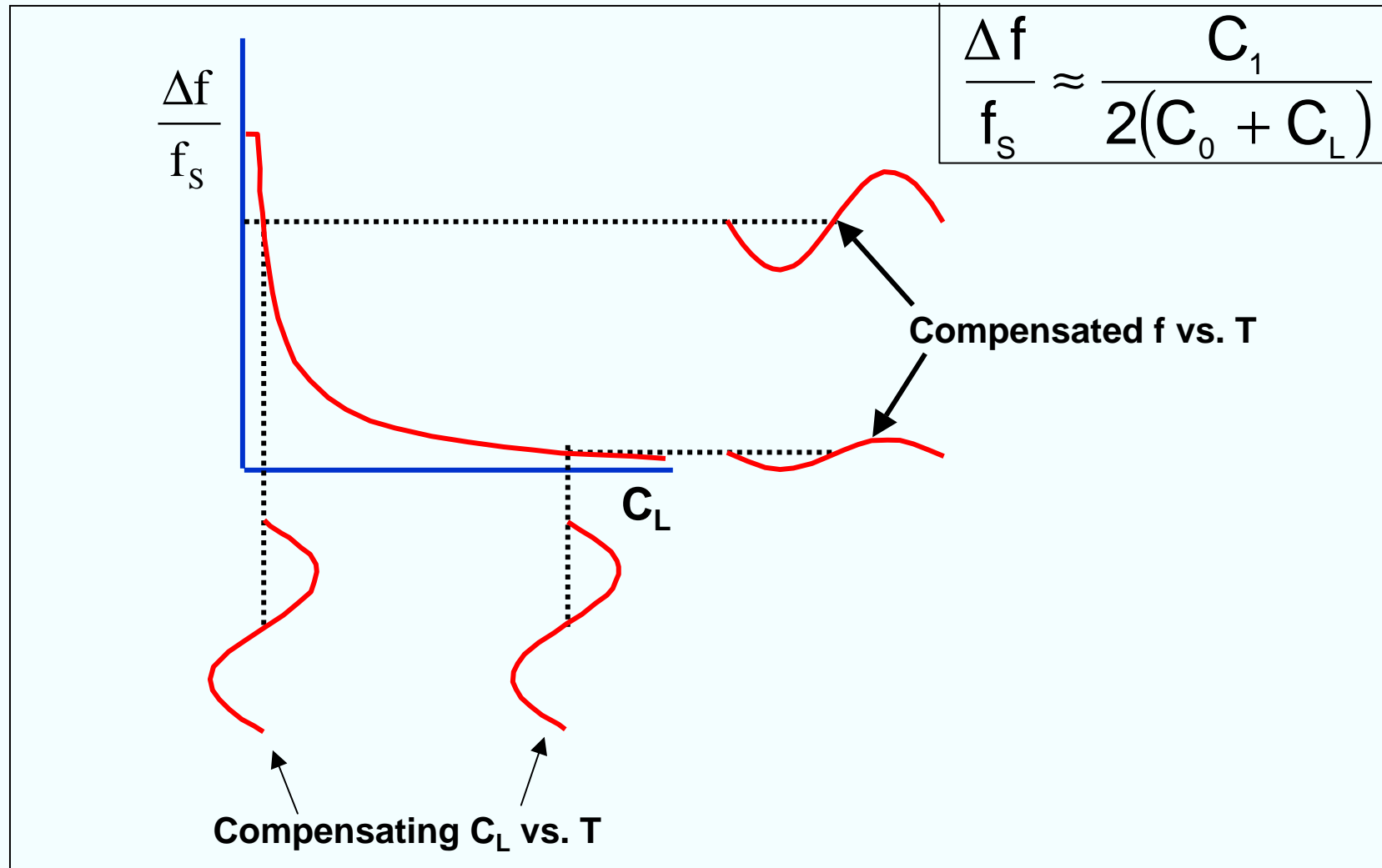



# Effects of Load Capacitance on f vs. T

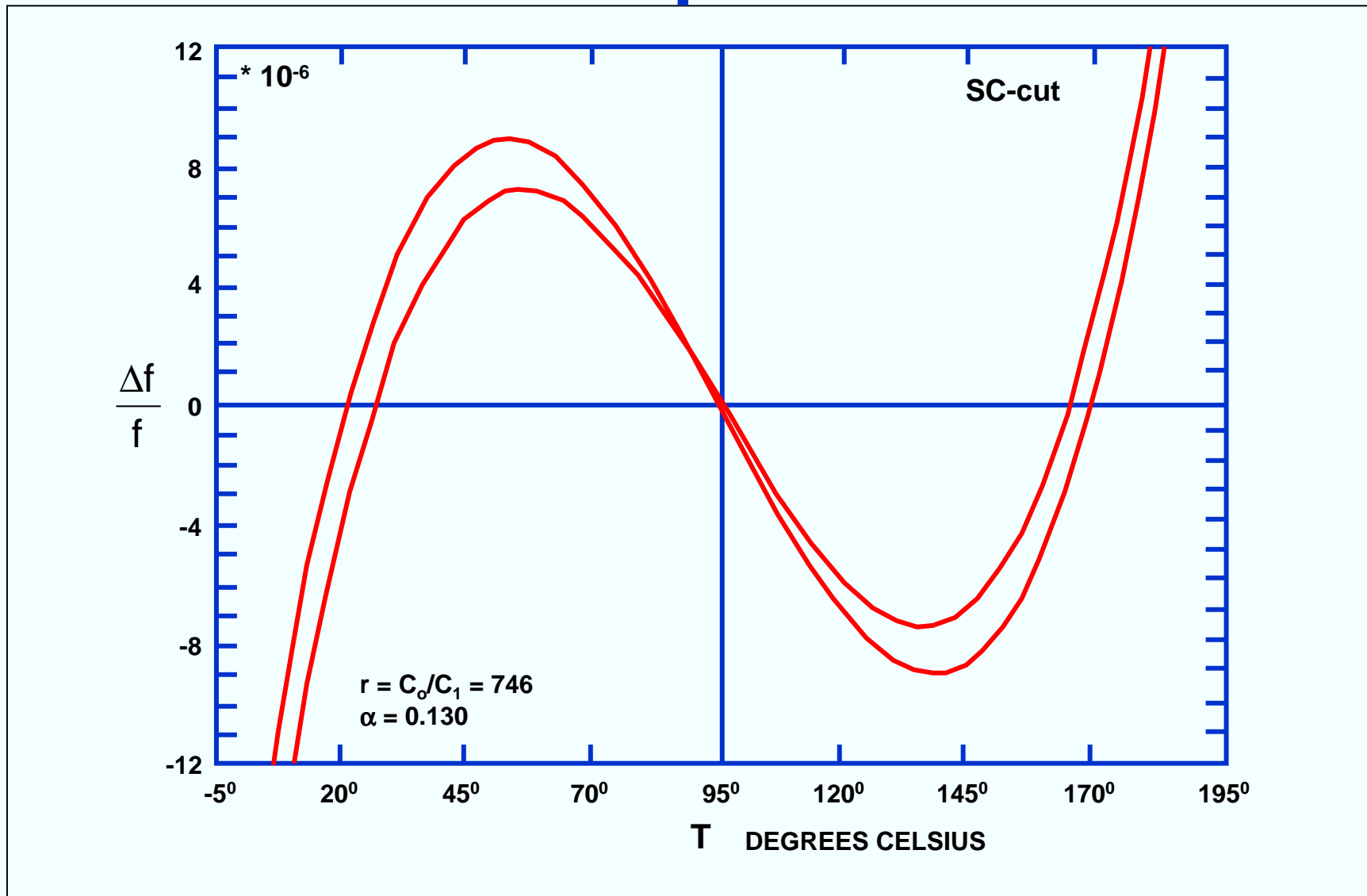

# Effects of Harmonics on $f$ vs. $T$

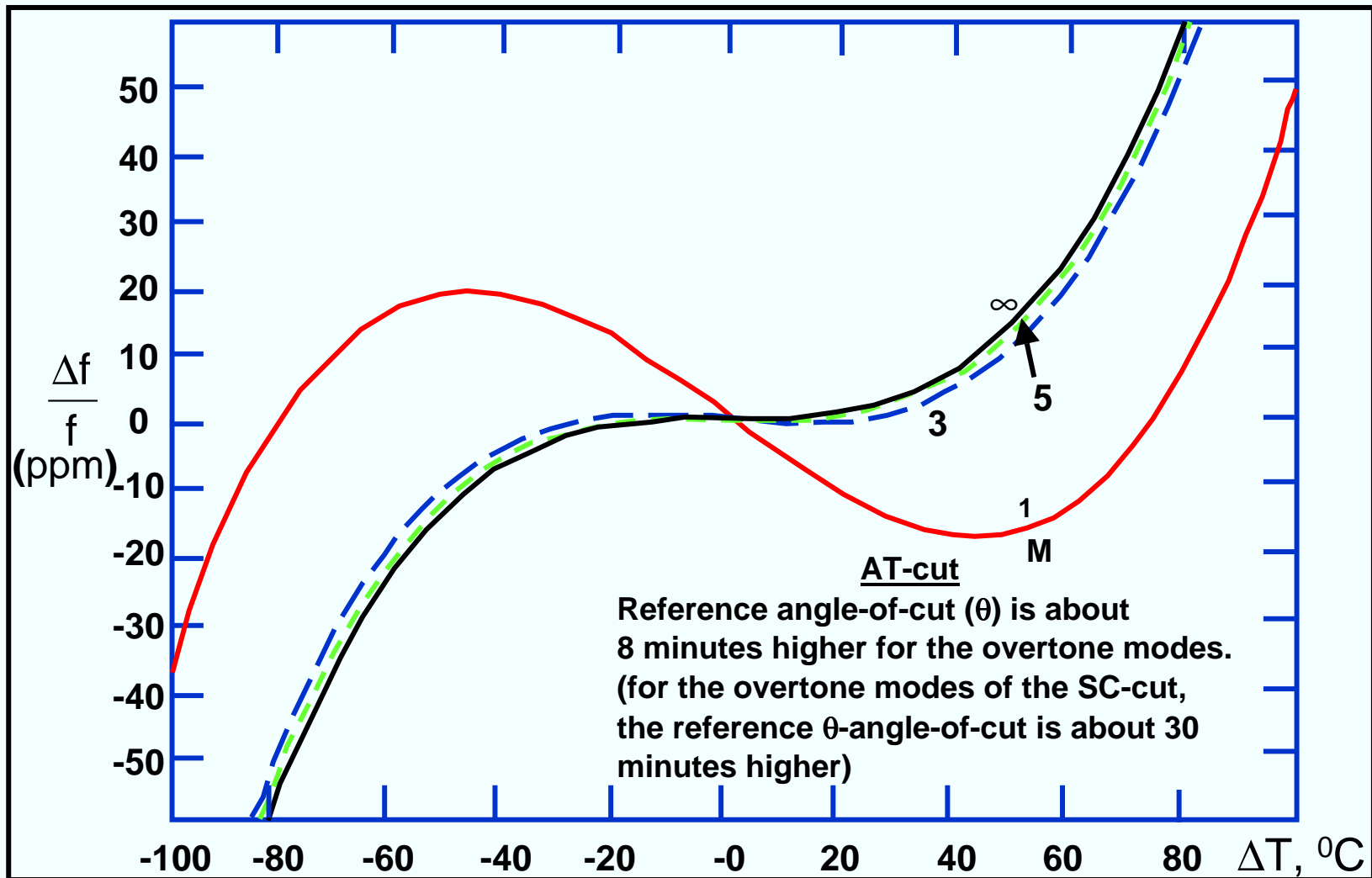

# Amplitude - Frequency Effect

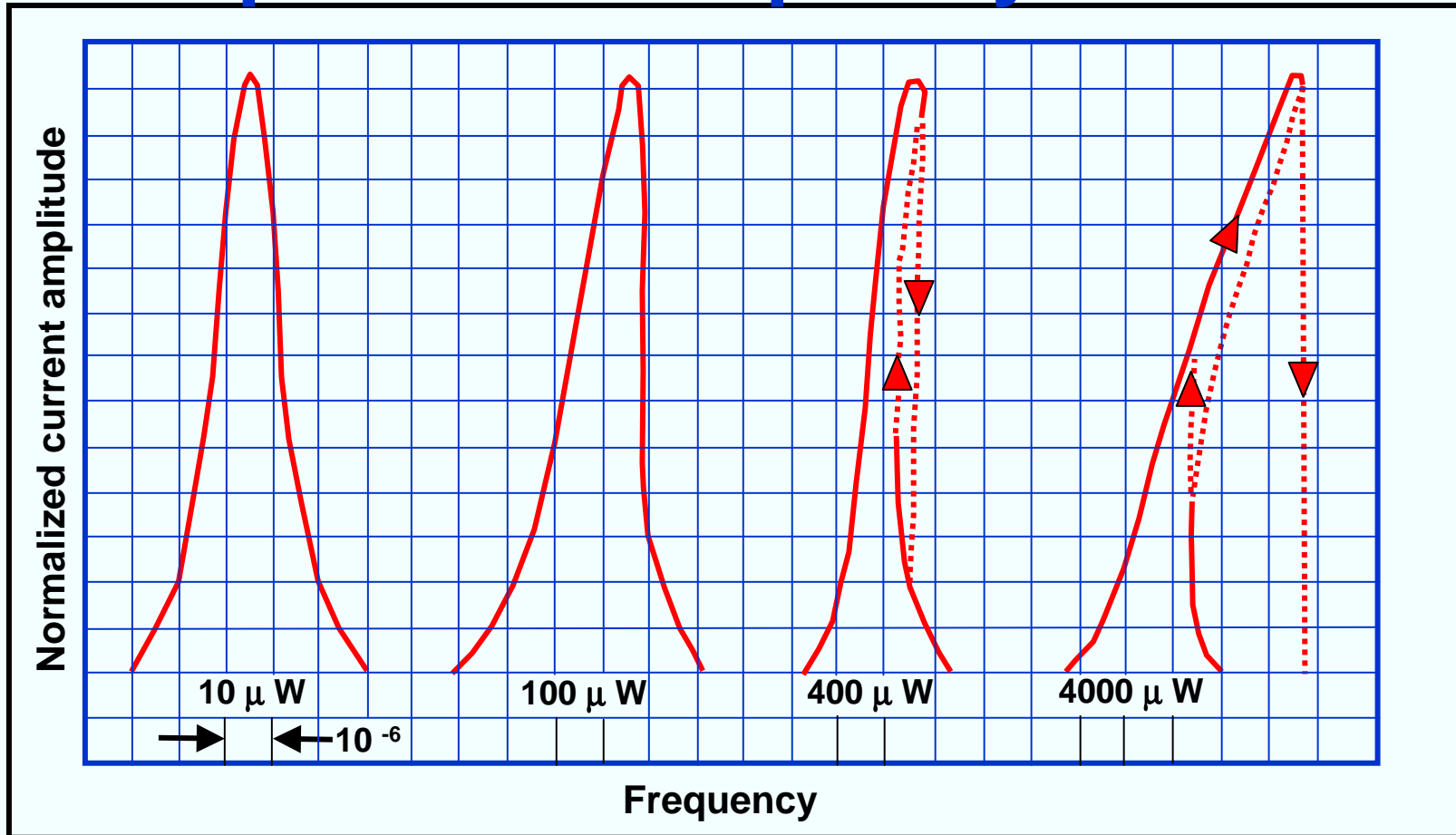

At high drive levels, resonance curves become asymmetric due to the nonlinearities of quartz.

# Frequency vs. Drive Level

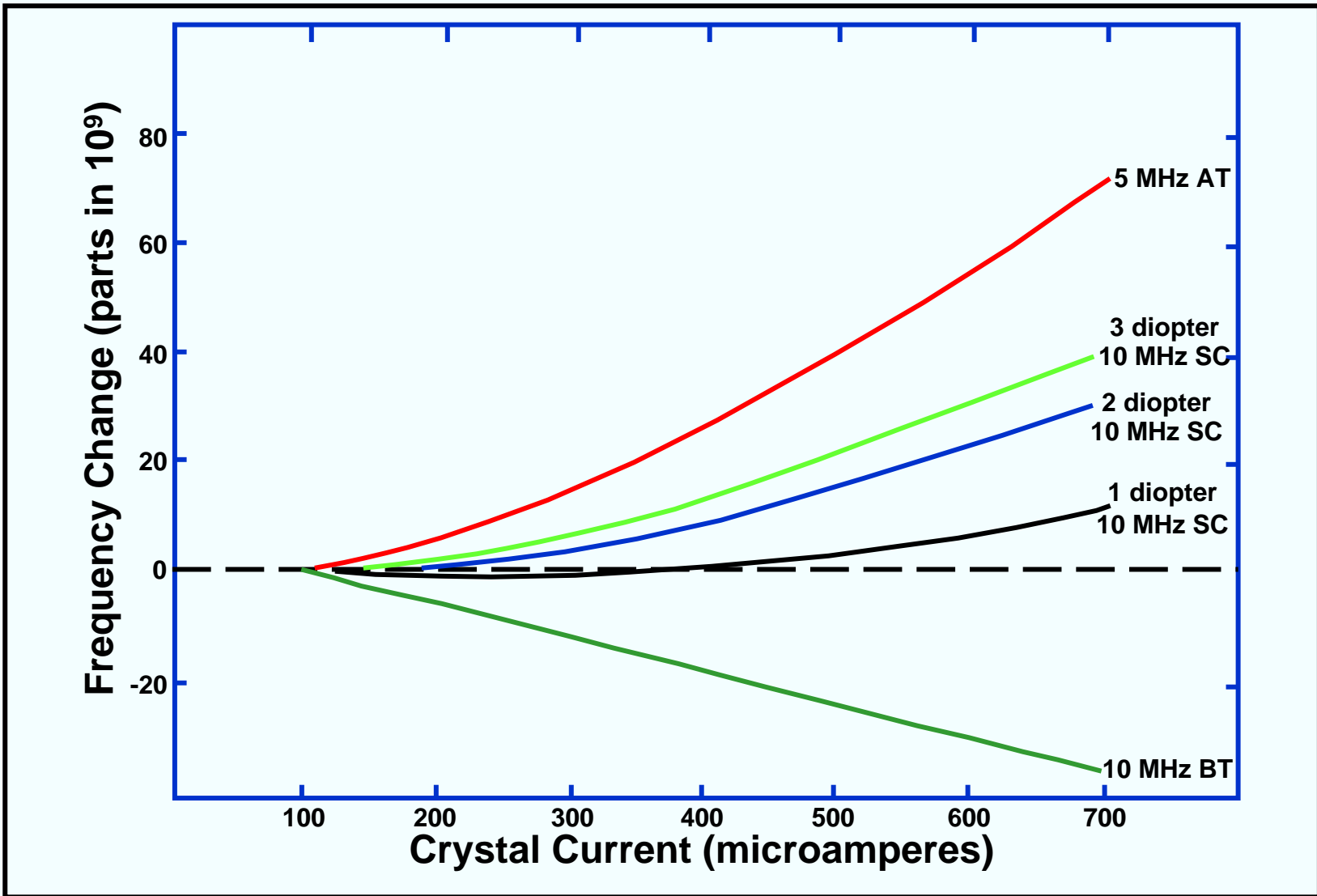

# Drive Level vs. Resistance

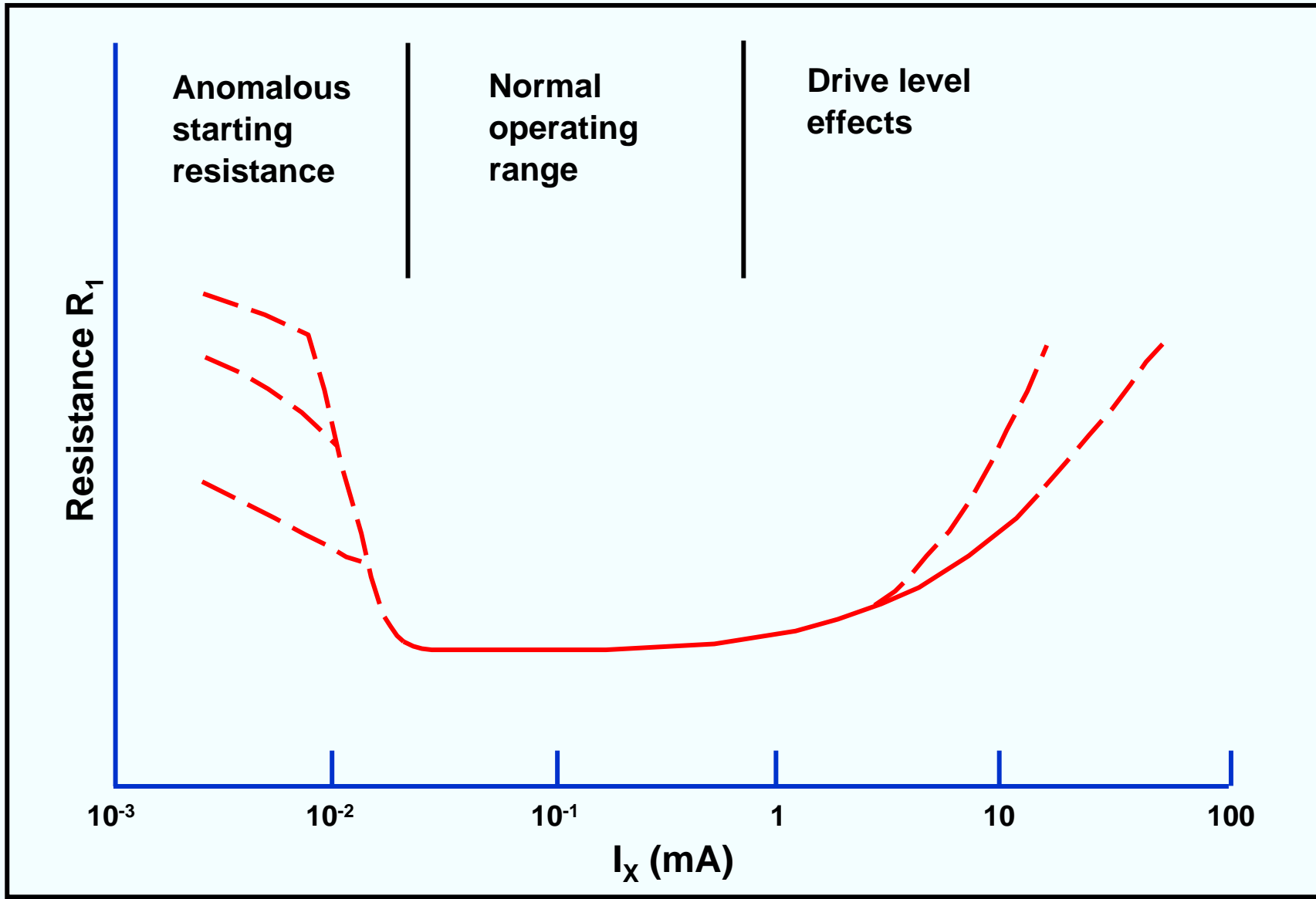

# Second Level of Drive Effect

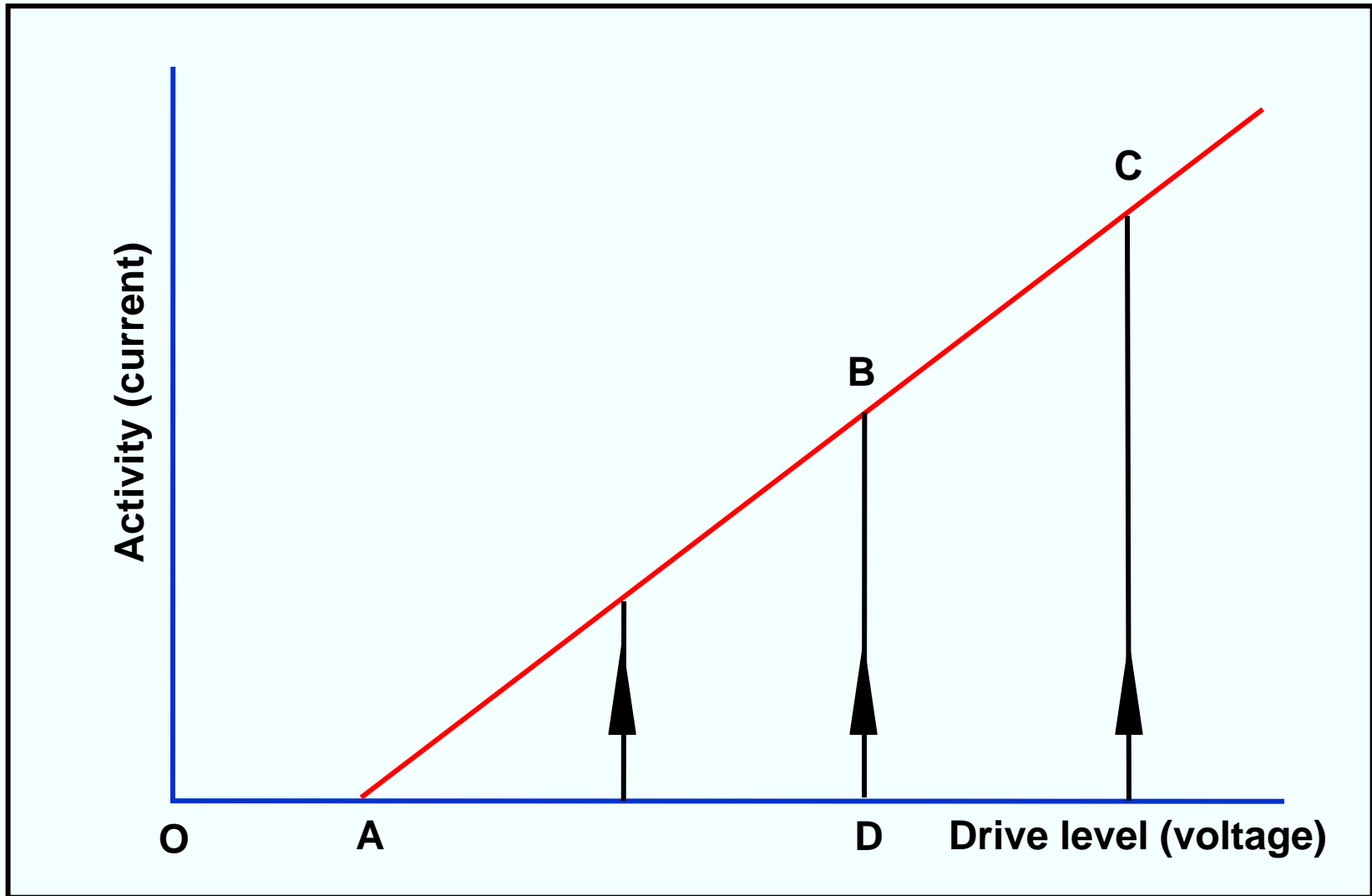

# Activity Dips

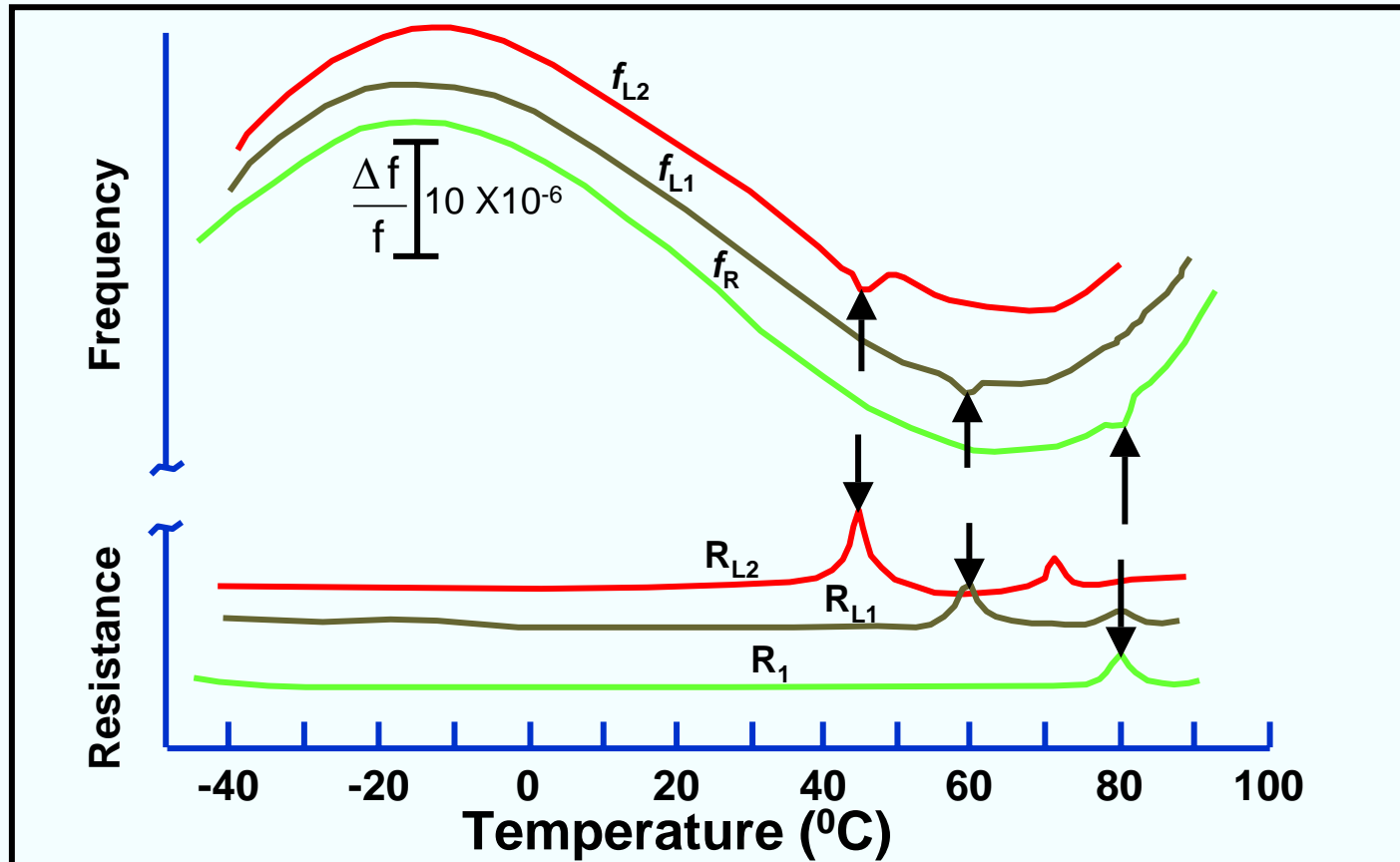

Activity dips in the  $f$  vs.  $T$  and  $R$  vs.  $T$  when operated with and without load capacitors. Dip temperatures are a function of  $C_L$ , which indicates that the dip is caused by a mode (probably flexure) with a large negative temperature coefficient.

# Frequency Jumps

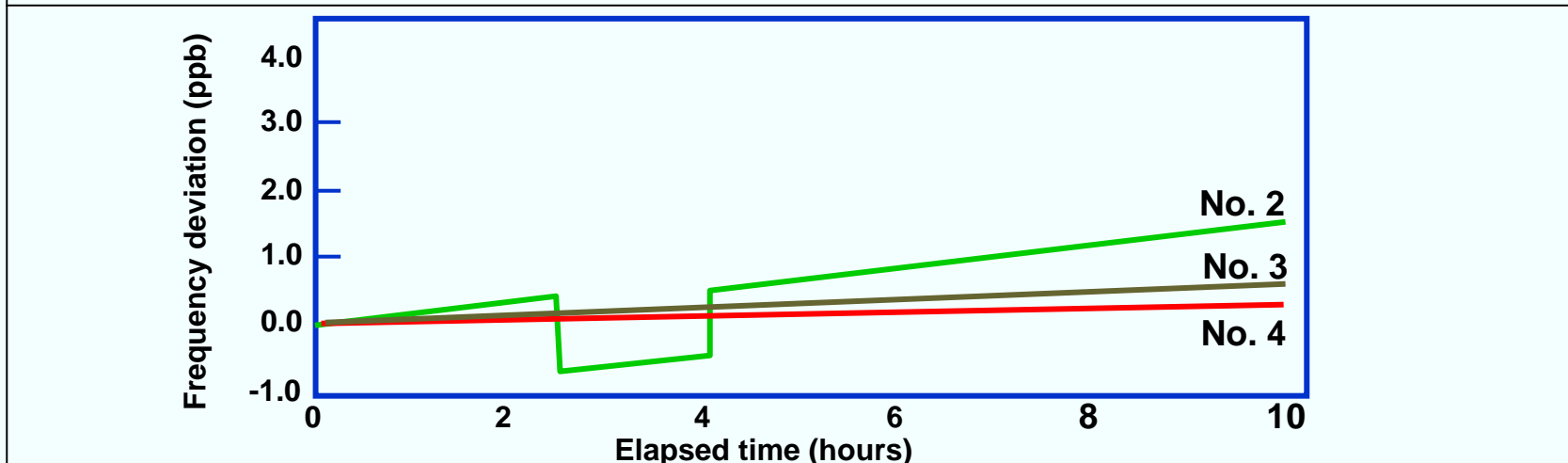
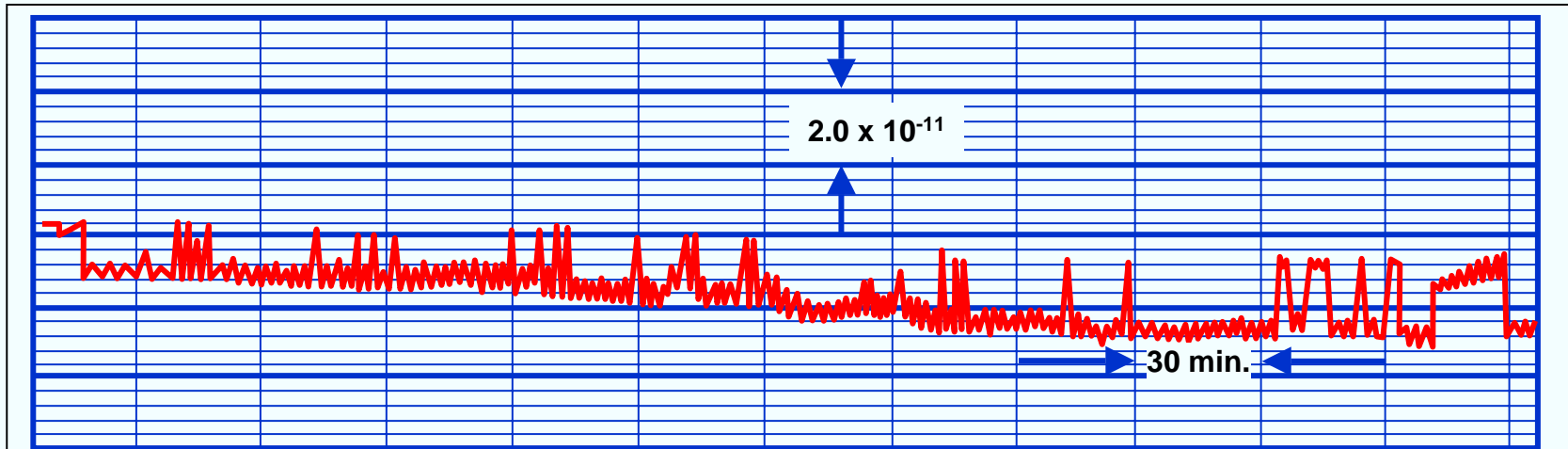



# Acceleration vs. Frequency Change

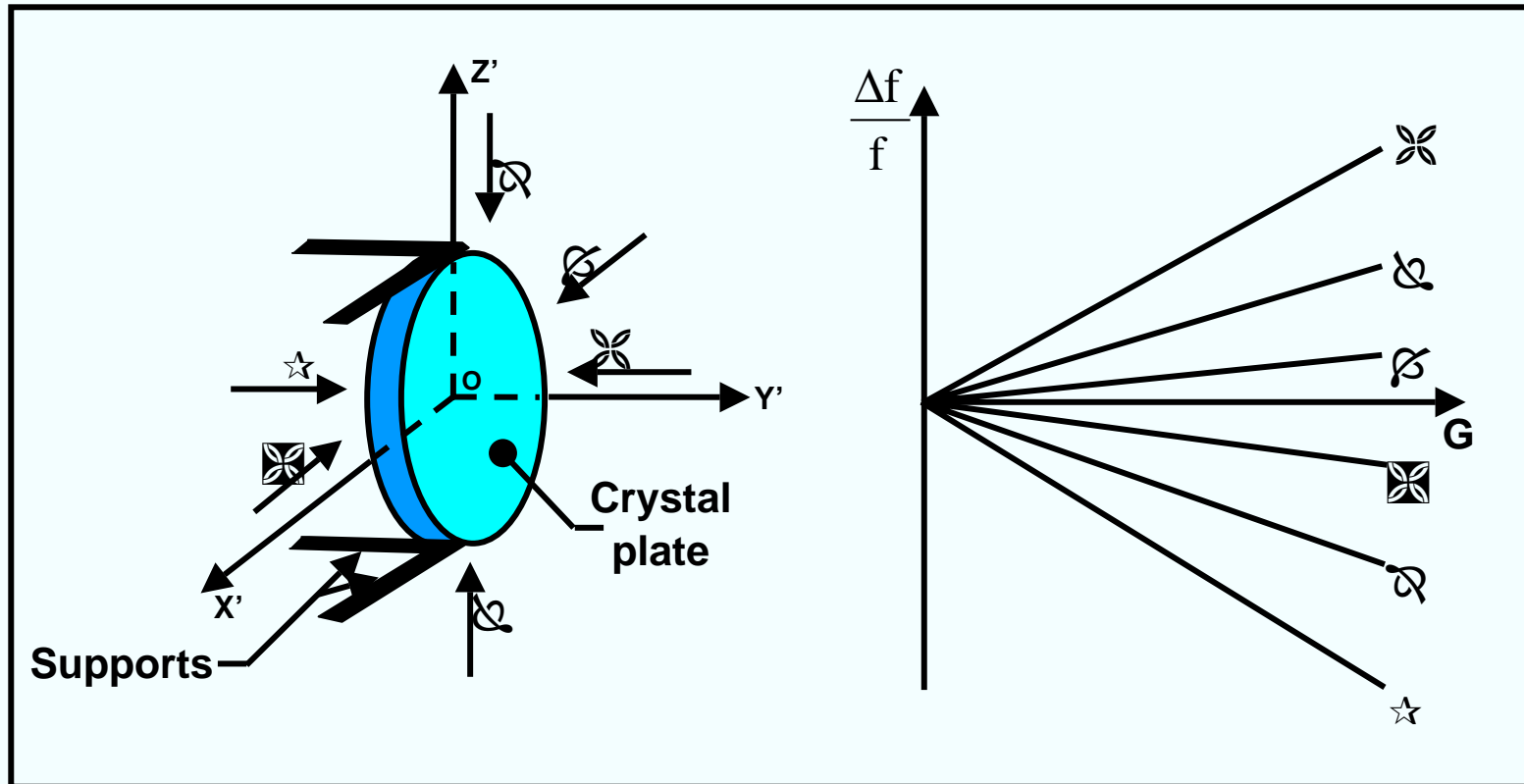

Frequency shift is a function of the magnitude and direction of the acceleration, and is usually linear with magnitude up to at least 50 g's.

# 2-g Tipover Test ( $\Delta f$ vs. attitude about three axes)

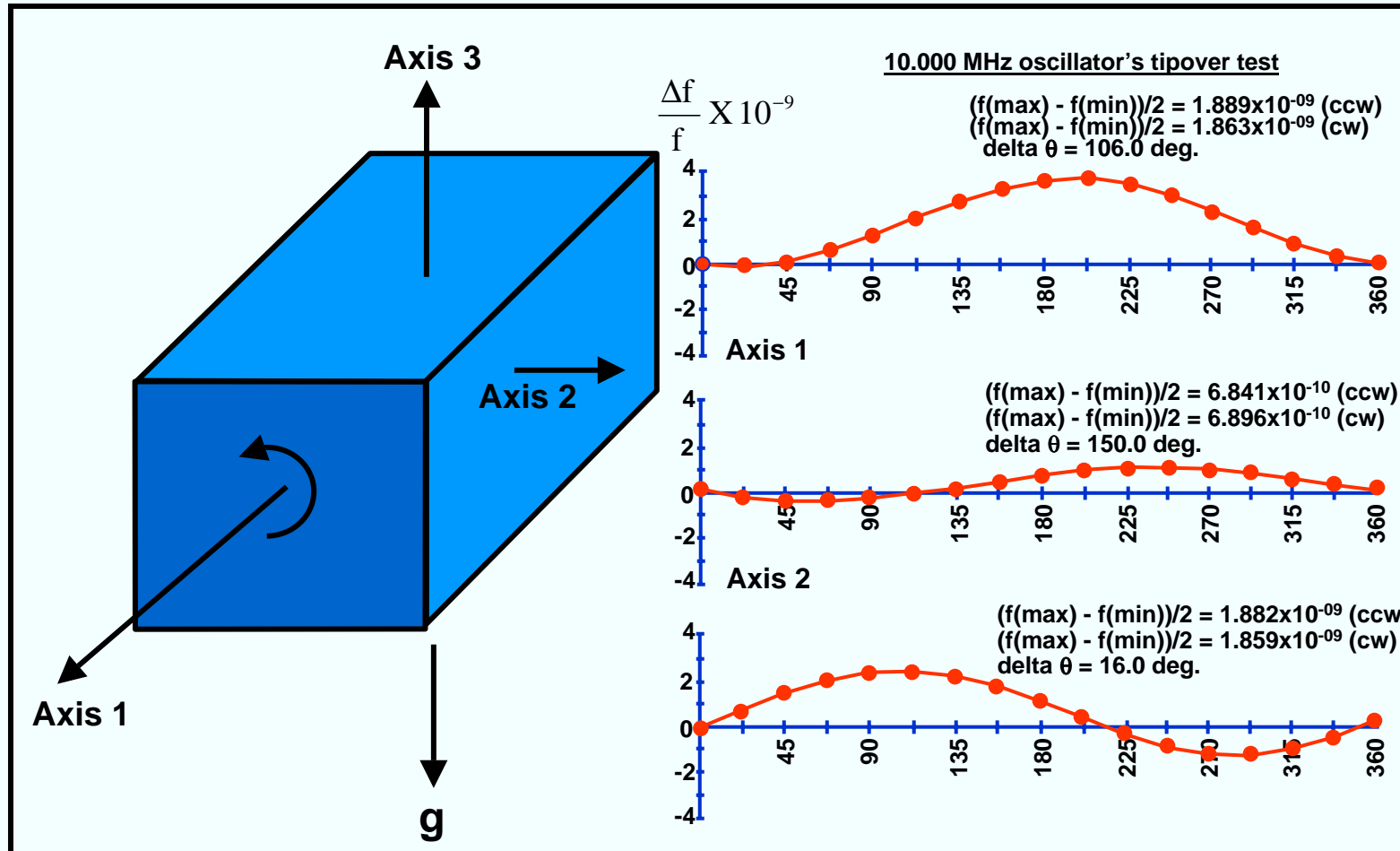

# Sinusoidal Vibration Modulated Frequency

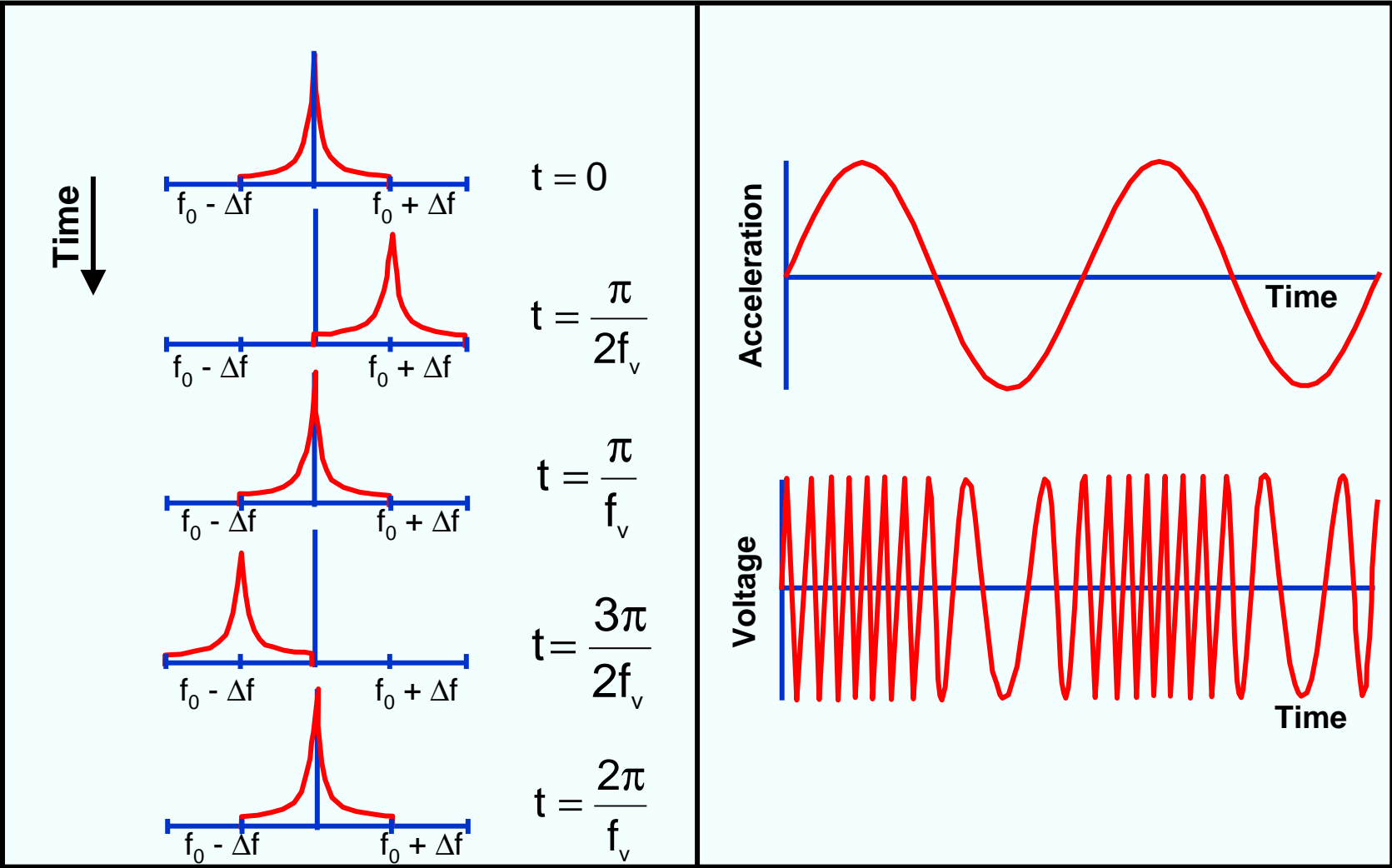

# Acceleration Levels and Effects

<b>Environment</b>	<b>Acceleration typical levels*, in g's</b>	<b><math>\Delta f</math> x10<sup>-11</sup>, for 1x10<sup>-9</sup>/g oscillator</b>
Buildings**, quiescent	0.02 rms	2
Tractor-trailer (3-80 Hz)	0.2 peak	20
Armored personnel carrier	0.5 to 3 rms	50 to 300
Ship - calm seas	0.02 to 0.1 peak	2 to 10
Ship - rough seas	0.8 peak	80
Propeller aircraft	0.3 to 5 rms	30 to 500
Helicopter	0.1 to 7 rms	10 to 700
Jet aircraft	0.02 to 2 rms	2 to 200
Missile - boost phase	15 peak	1,500
Railroads	0.1 to 1 peak	10 to 100

\* Levels at the oscillator depend on how and where the oscillator is mounted  
Platform resonances can greatly amplify the acceleration levels.

\*\* Building vibrations can have significant effects on noise measurements

# Acceleration Sensitivity Vector

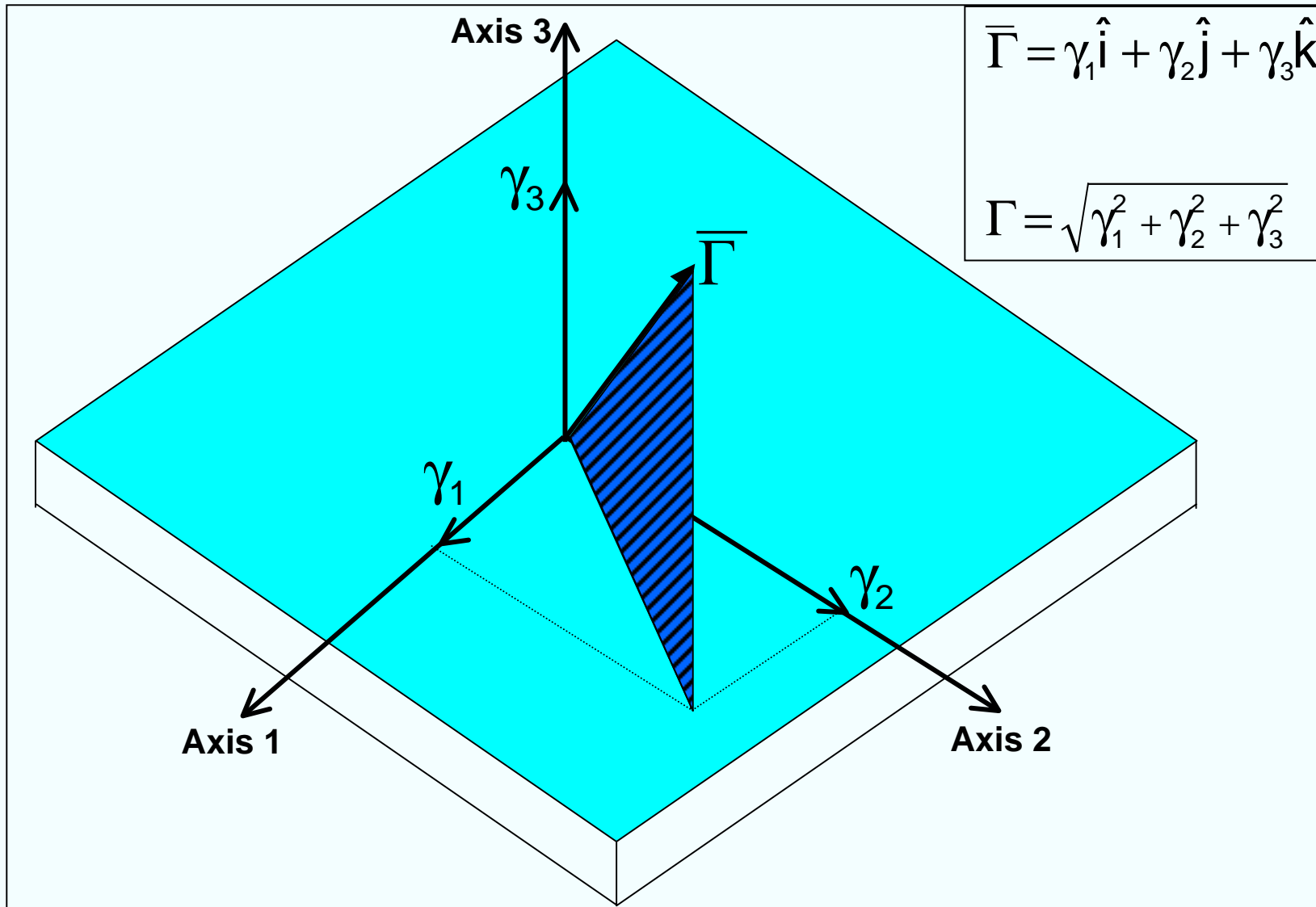

# Vibration-Induced Allan Deviation Degradation

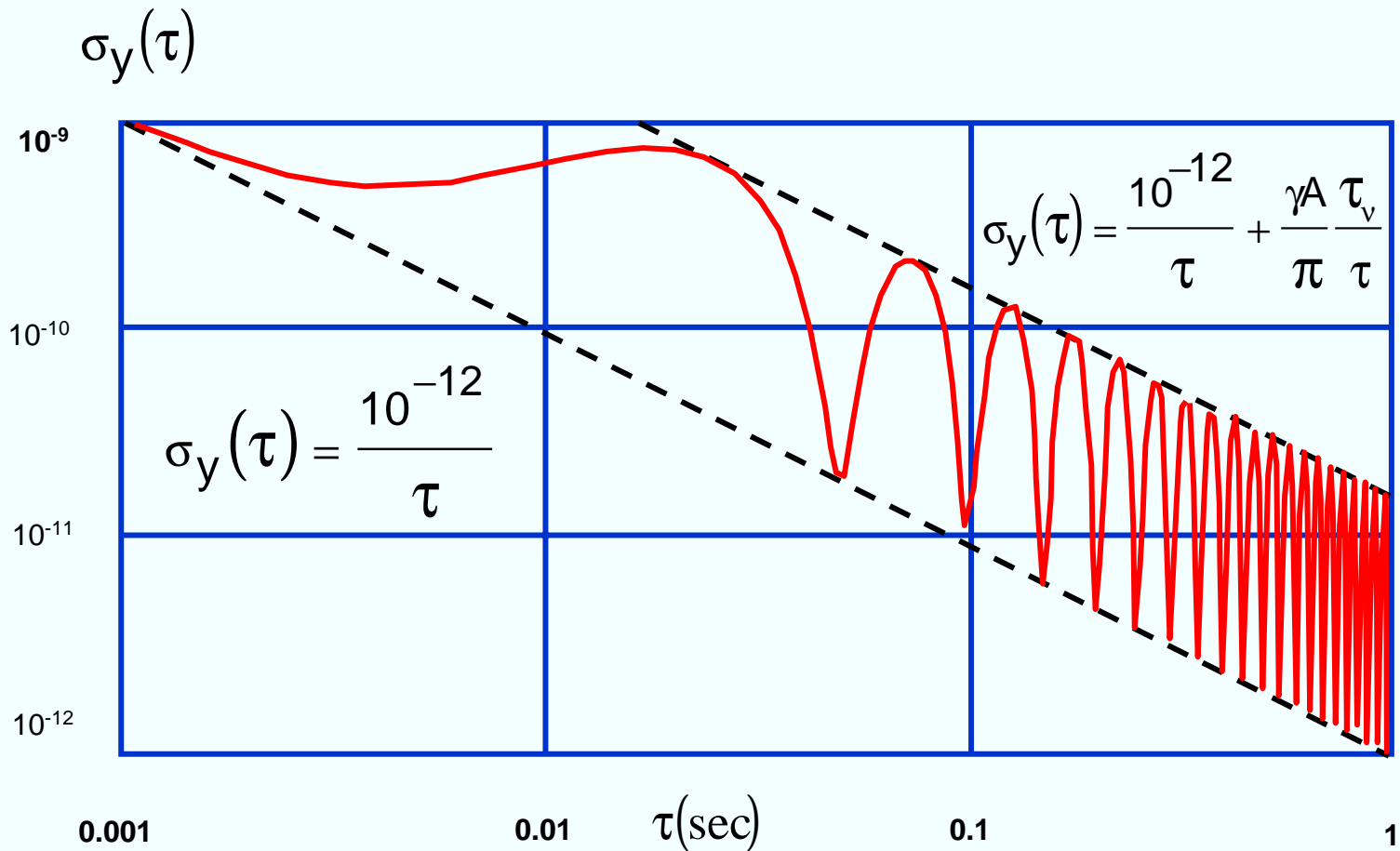

**Example shown:**  $f_v = 20, \text{ Hz}$   $A = 1.0 \text{ g}$  along  $\Gamma$ ,  $|\Gamma| = 1 \times 10^{-9}/\text{g}$

# Vibration-Induced Phase Excursion

The phase of a vibration modulated signal is

$$\varphi(t) = 2\pi f_0 t + \left( \frac{\Delta f}{f_v} \right) \sin(2\pi f_v t)$$

When the oscillator is subjected to a sinusoidal vibration, the peak phase excursion is

$$\Delta \varphi_{\text{peak}} = \frac{\Delta f}{f_v} = \frac{(\overline{\Gamma} \bullet \overline{A}) f_0}{f_v}$$

Example: if a 10 MHz,  $1 \times 10^{-9}/g$  oscillator is subjected to a 10 Hz sinusoidal vibration of amplitude 1g, the peak vibration-induced phase excursion is  $1 \times 10^{-3}$  radian. If this oscillator is used as the reference oscillator in a 10 GHz radar system, the peak phase excursion at 10GHz will be 1 radian. Such a large phase excursion can be catastrophic to the performance of many systems, such as those which employ phase locked loops (PLL) or phase shift keying (PSK).

# Vibration-Induced Sidebands

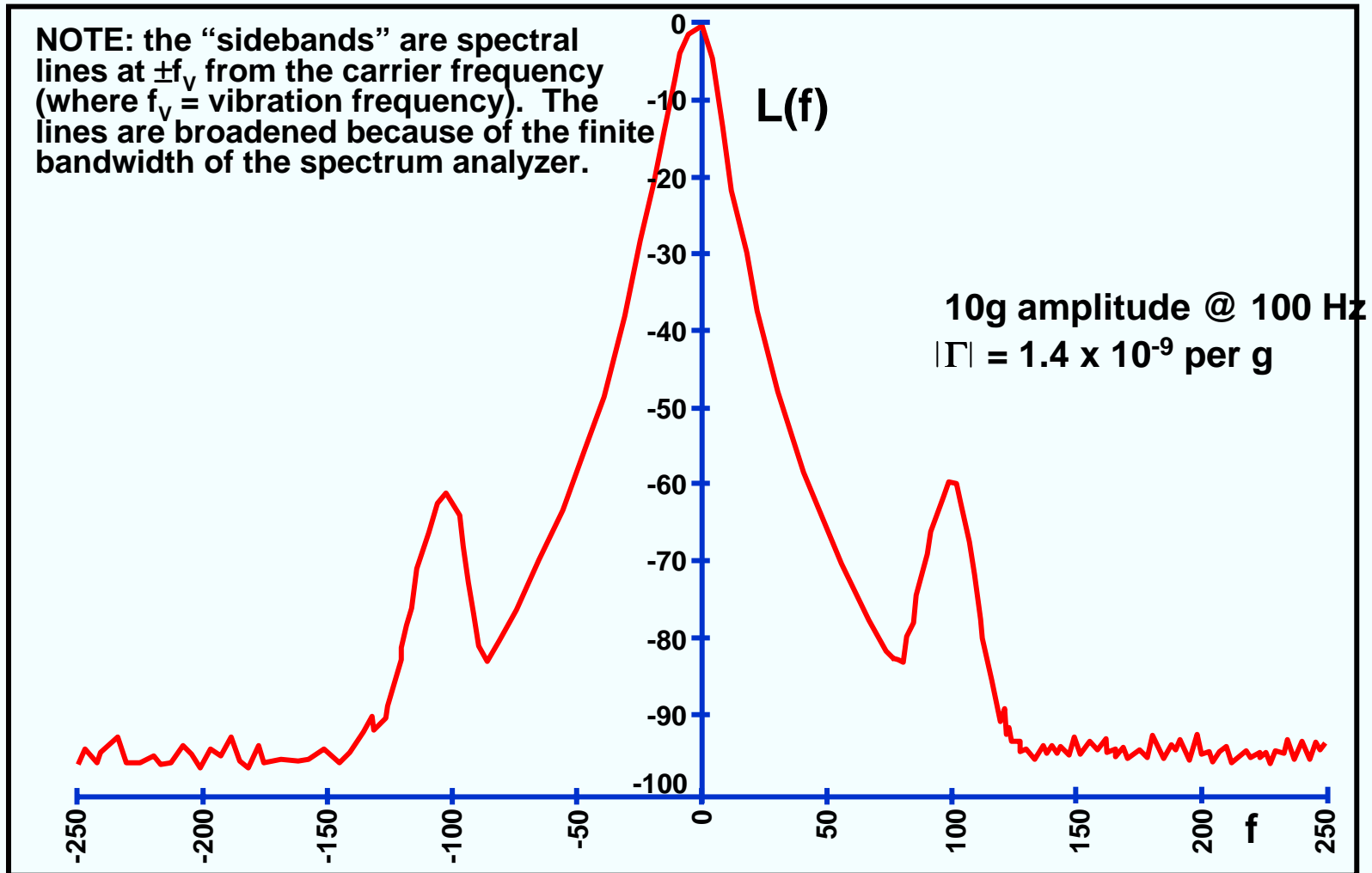



# Vibration-Induced Sidebands

## After Frequency Multiplication

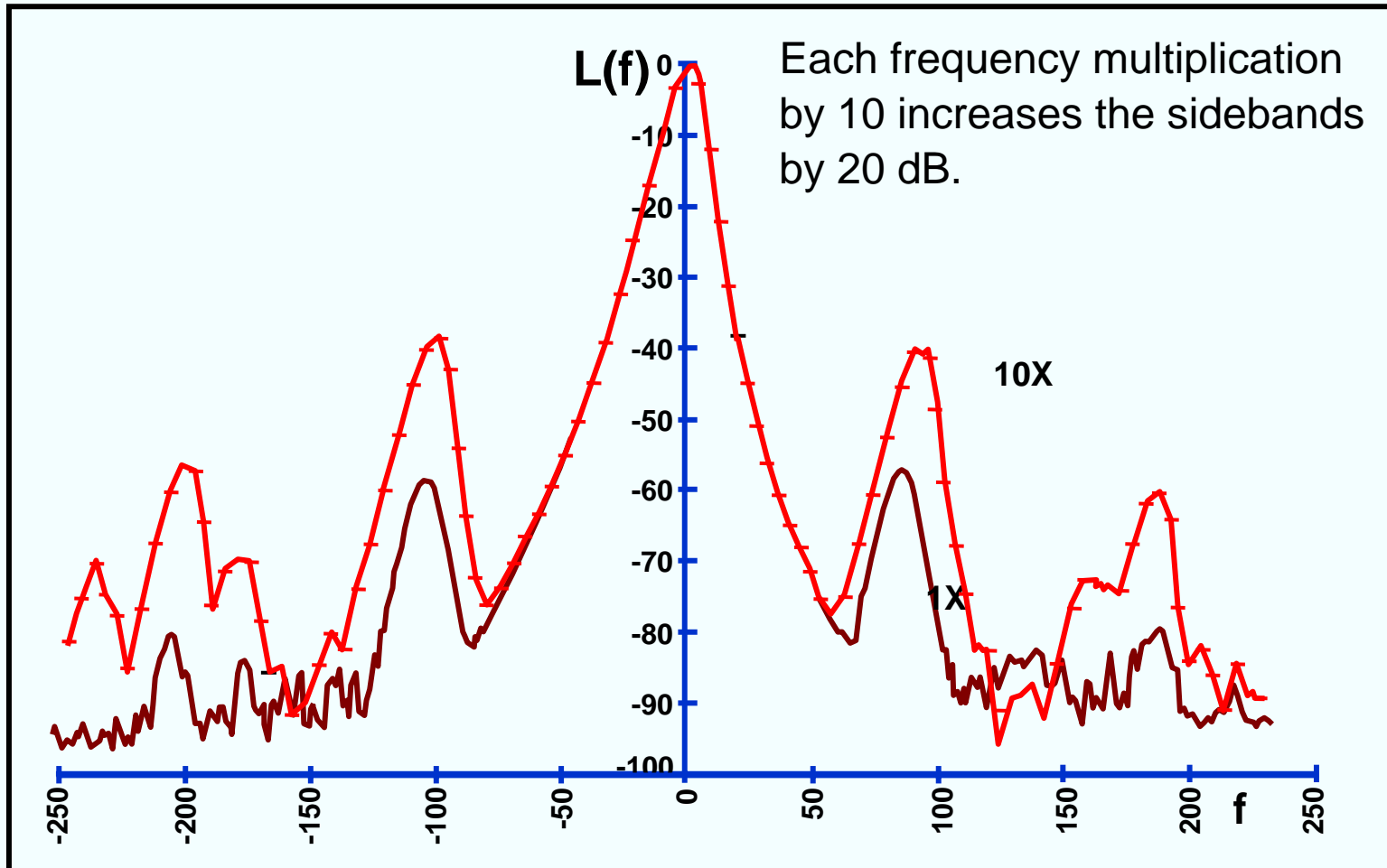

# Sine Vibration-Induced Phase Noise

Sinusoidal vibration produces spectral lines at  $\pm f_v$  from the carrier, where  $f_v$  is the vibration frequency.

$$L'(f_v) = 20 \log \left( \frac{\bar{\Gamma} \cdot \bar{A}f_0}{2f_v} \right)$$

e.g., if  $|\bar{\Gamma}| = 1 \times 10^{-9}/g$  and  $f_0 = 10$  MHz, then even if the oscillator is completely **noise free at rest**, the phase “noise” i.e., the spectral lines, due solely to a sine vibration level of 1g will be;

Vibr. freq., $f_v$ , in Hz	$L'(f_v)$ , in dBc
1	-46
10	-66
100	-86
1,000	-106
10,000	-126

# Random Vibration-Induced Phase Noise

Random vibration's contribution to phase noise is given by:

$$L(f) = 20 \log \left( \frac{\bar{\Gamma} \cdot \bar{A}f_0}{2f} \right), \quad \text{where } |\bar{A}| = [(2)(\text{PSD})]^{1/2}$$

e.g., if  $|\bar{\Gamma}| = 1 \times 10^{-9}/g$  and  $f_0 = 10 \text{ MHz}$ , then even if the oscillator is completely **noise free at rest**, the phase “noise” i.e., the spectral lines, due solely to a vibration PSD = 0.1 g<sup>2</sup>/Hz will be:

Offset freq., f, in Hz	L'(f), in dBc/Hz
1	-53
10	-73
100	-93
1,000	-113
10,000	-133

# Random-Vibration-Induced Phase Noise

Phase noise under vibration is for  $\Gamma = 1 \times 10^{-9}$  per g and  $f = 10$  MHz

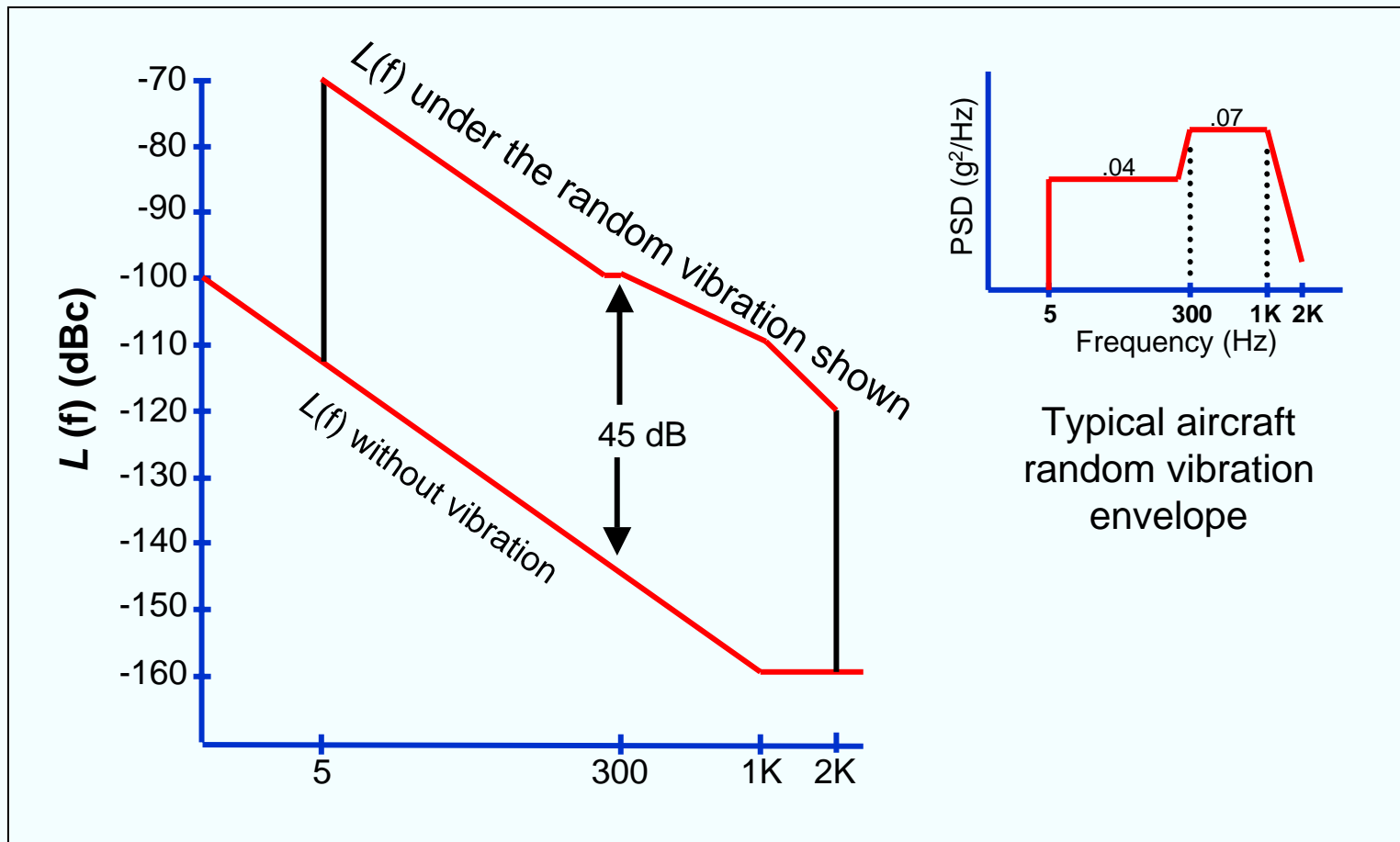

# Acceleration Sensitivity vs. Vibration Frequency

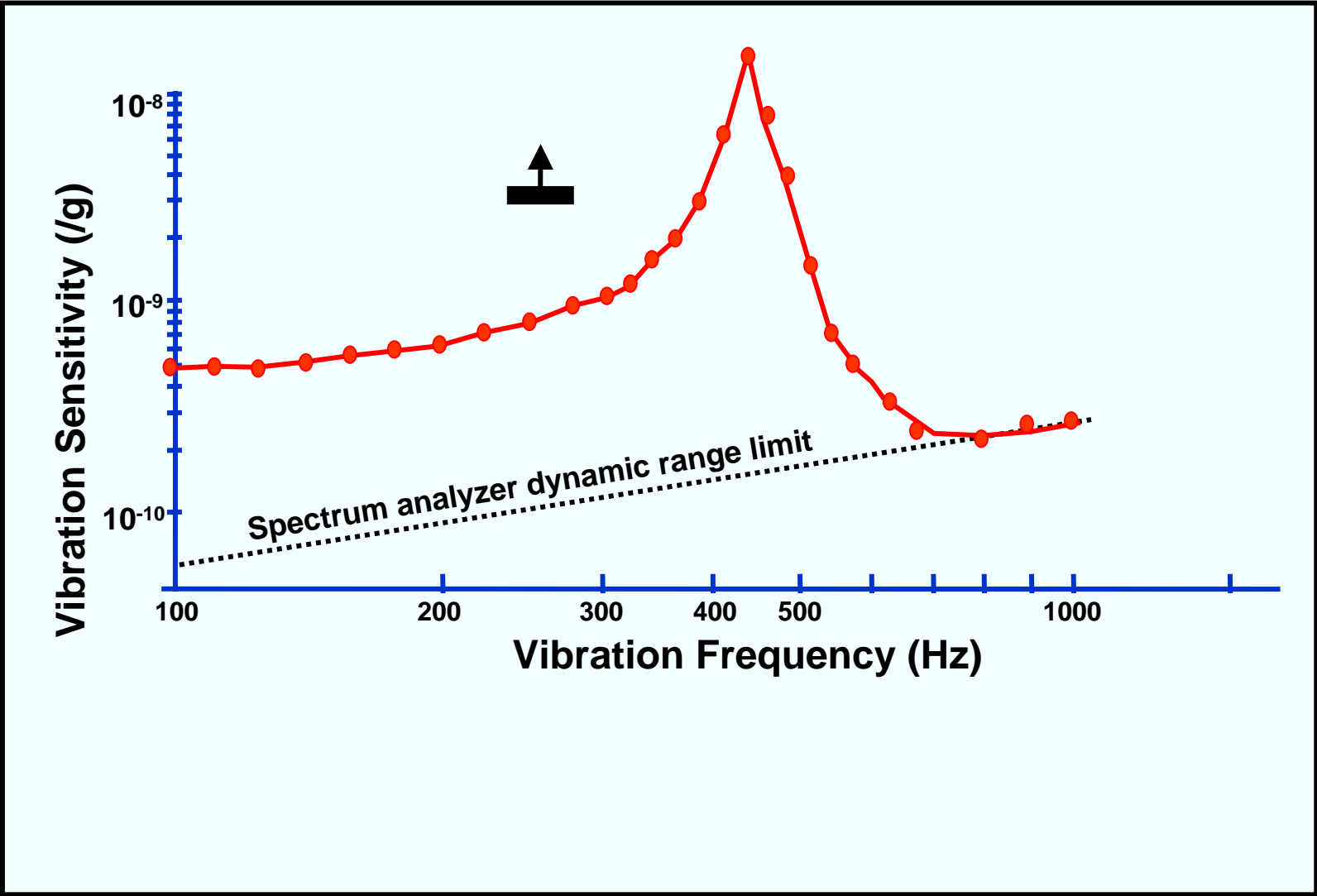

# Acceleration Sensitivity of Quartz Resonators

Resonator acceleration sensitivities range from the low parts in  $10^{10}$  per g for the best commercially available SC-cuts, to parts in  $10^7$  per g for tuning-fork-type watch crystals. When a wide range of resonators were examined: AT, BT, FC, IT, SC, AK, and GT-cuts; 5 MHz 5th overtones to 500 MHz fundamental mode inverted mesa resonators; resonators made of natural quartz, cultured quartz, and swept cultured quartz; numerous geometries and mounting configurations (including rectangular AT-cuts); nearly all of the results were within a factor of three of  $1 \times 10^{-9}$  per g. On the other hand, the fact that a few resonators have been found to have sensitivities of less than  $1 \times 10^{-10}$  per g indicates that the observed acceleration sensitivities are not due to any inherent natural limitations.

Theoretical and experimental evidence indicates that the major variables yet to be controlled properly are the mode shape and location (i.e., the amplitude of vibration distribution), and the strain distribution associated with the mode of vibration. Theoretically, when the mounting is completely symmetrical with respect to the mode shape, the acceleration sensitivity can be zero, but tiny changes from this ideal condition can cause a significant sensitivity. Until the acceleration sensitivity problem is solved, acceleration compensation and vibration isolation can provide lower than  $1 \times 10^{-10}$  per g, for a limited range of vibration frequencies, and at a cost.

# Phase Noise Degradation Due to Vibration

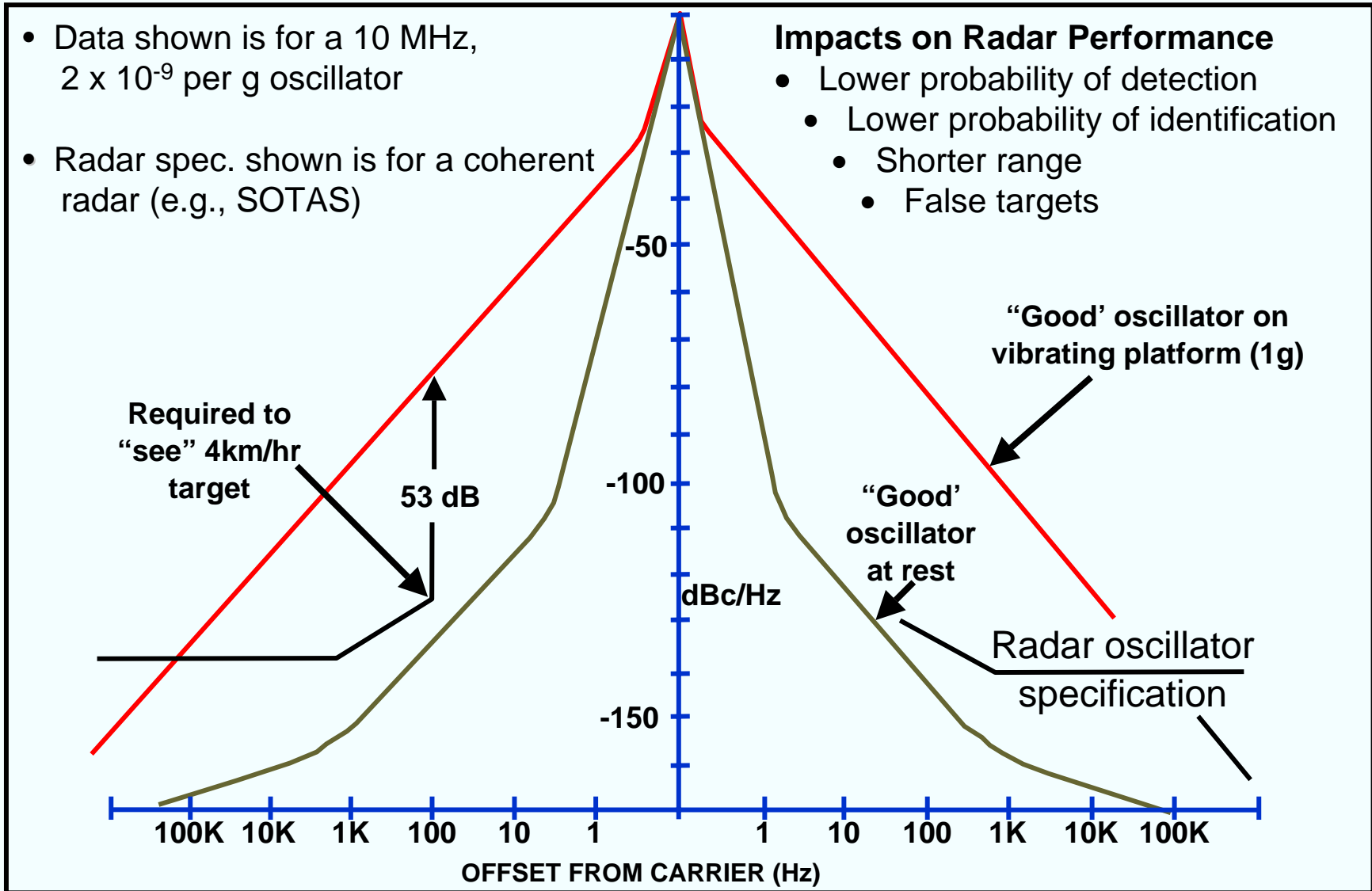

# Coherent Radar Probability of Detection

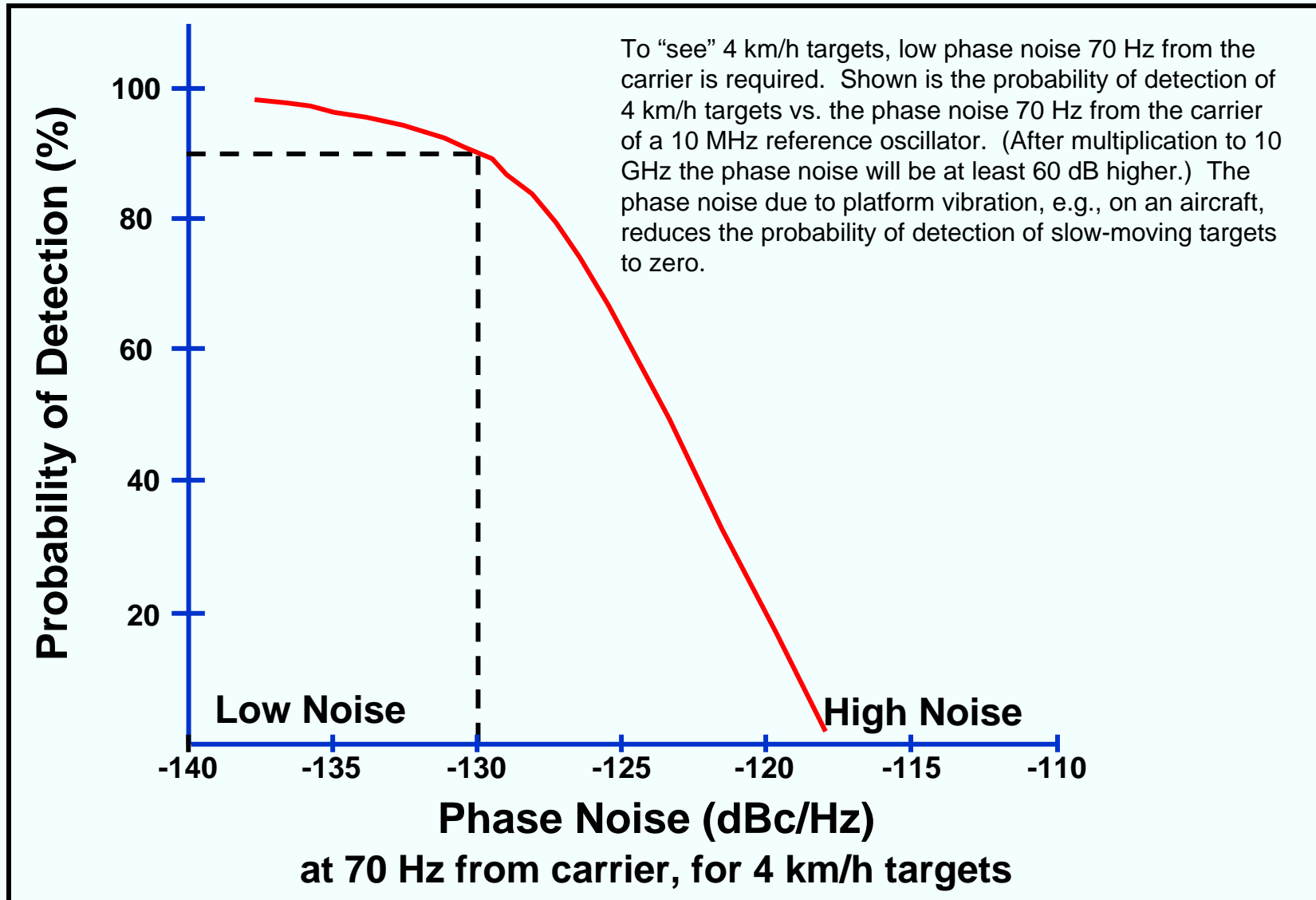



# Vibration Isolation

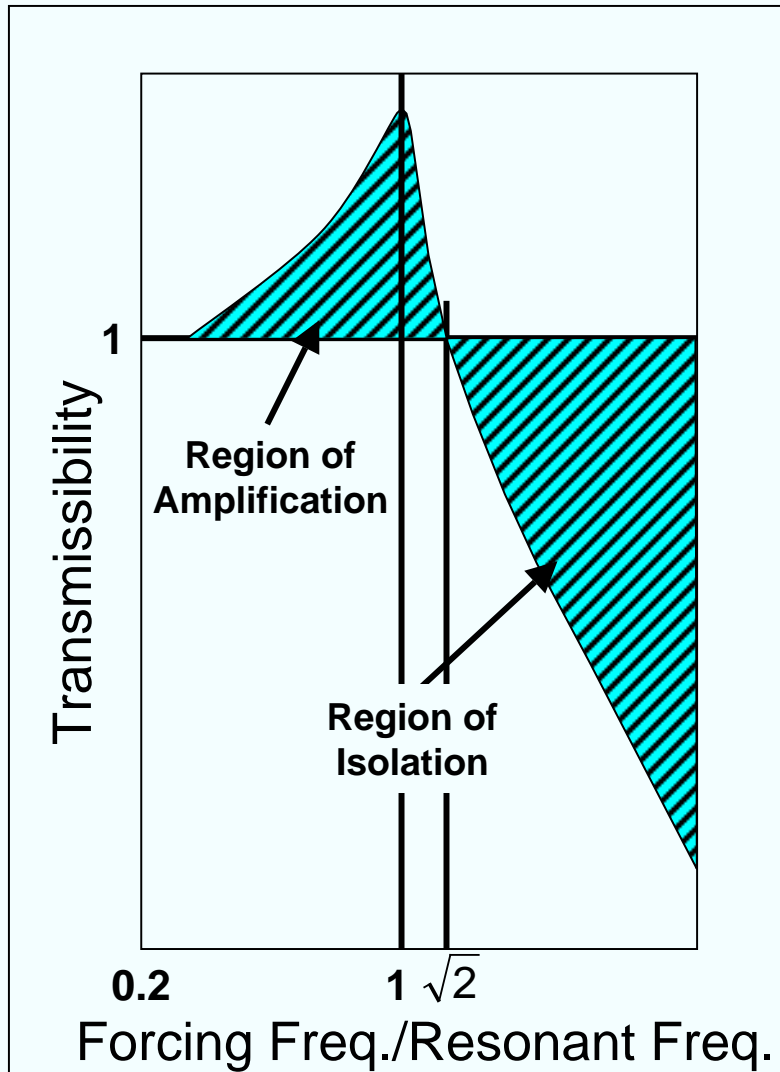

## Limitations

- Poor at low frequencies
- Adds size, weight and cost
- Ineffective for acoustic noise

# Vibration Compensation

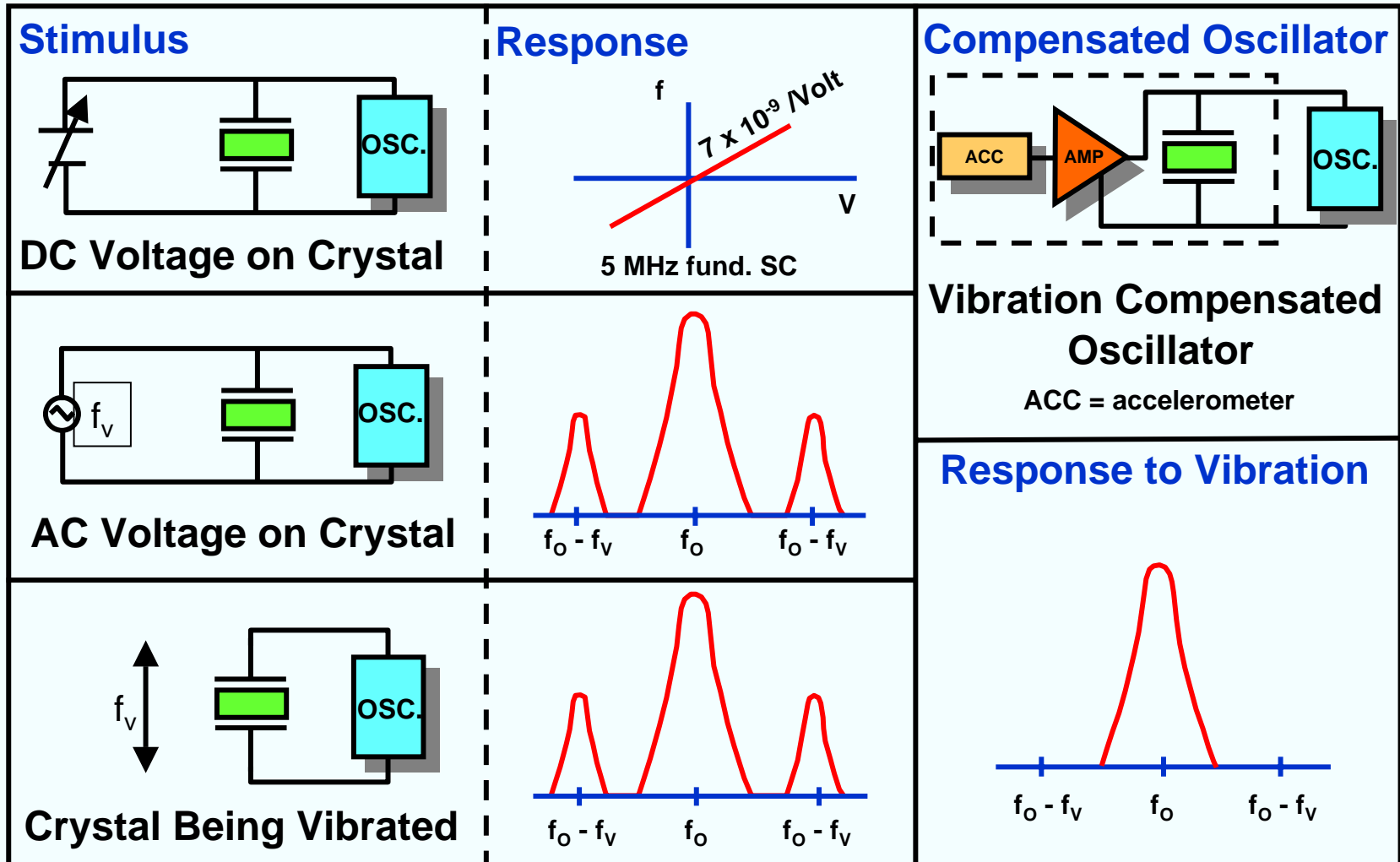

# Vibration Sensitivity Measurement System

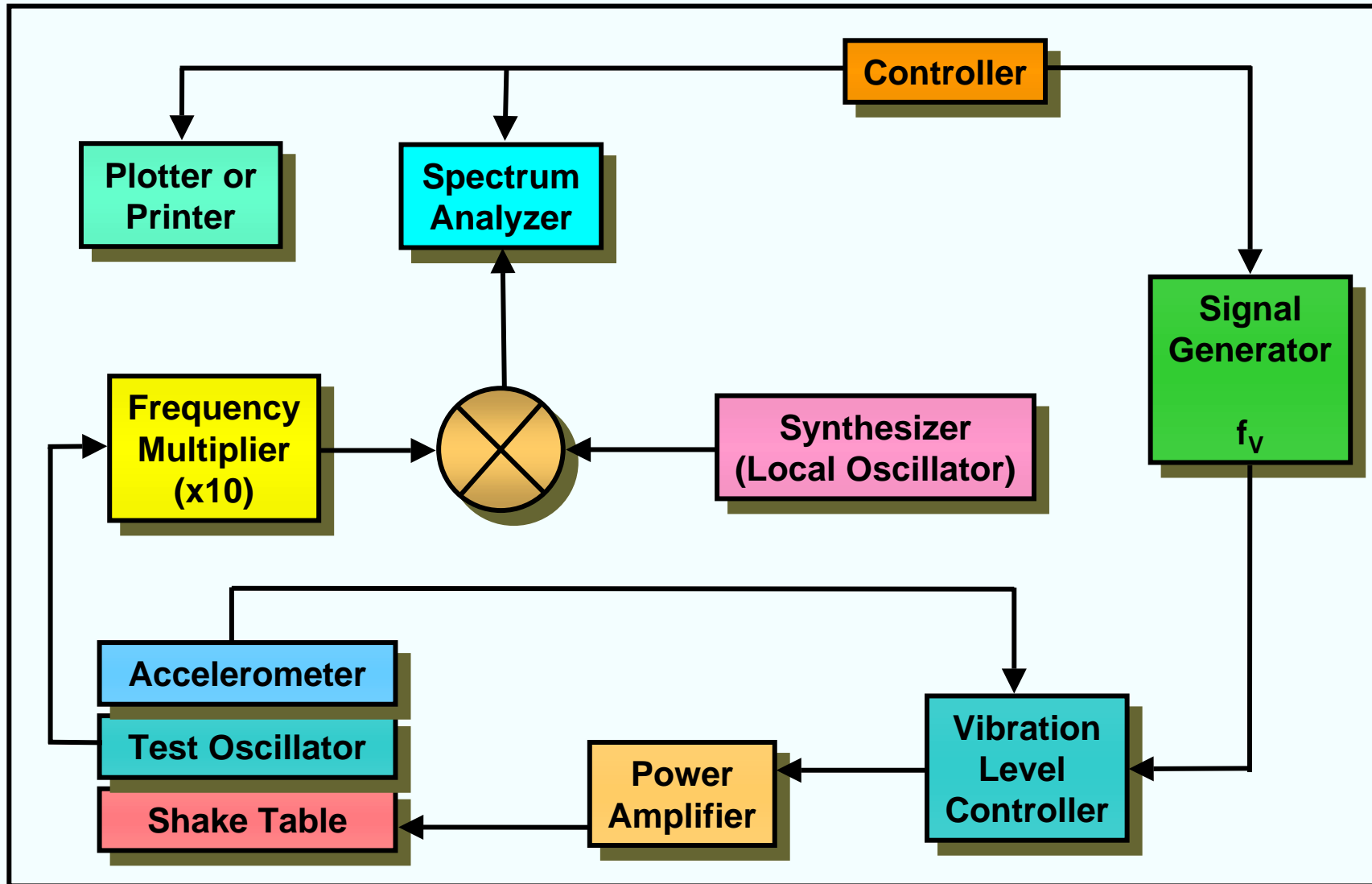

# Shock

The frequency excursion during a shock is due to the resonator's stress sensitivity. The magnitude of the excursion is a function of resonator design, and of the shock induced stresses on the resonator (resonances in the mounting structure will amplify the stresses.) The permanent frequency offset can be due to: shock induced stress changes, the removal of (particulate) contamination from the resonator surfaces, and changes in the oscillator circuitry. Survival under shock is primarily a function of resonator surface imperfections. Chemical-polishing-produced scratch-free resonators have survived shocks up to 36,000 g in air gun tests, and have survived the shocks due to being fired from a 155 mm howitzer (16,000 g, 12 ms duration).

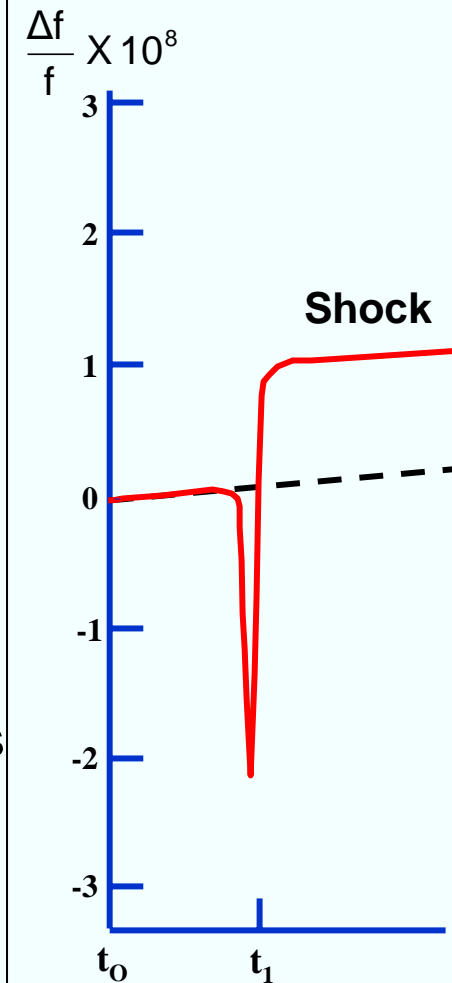

# Radiation-Induced Frequency Shifts

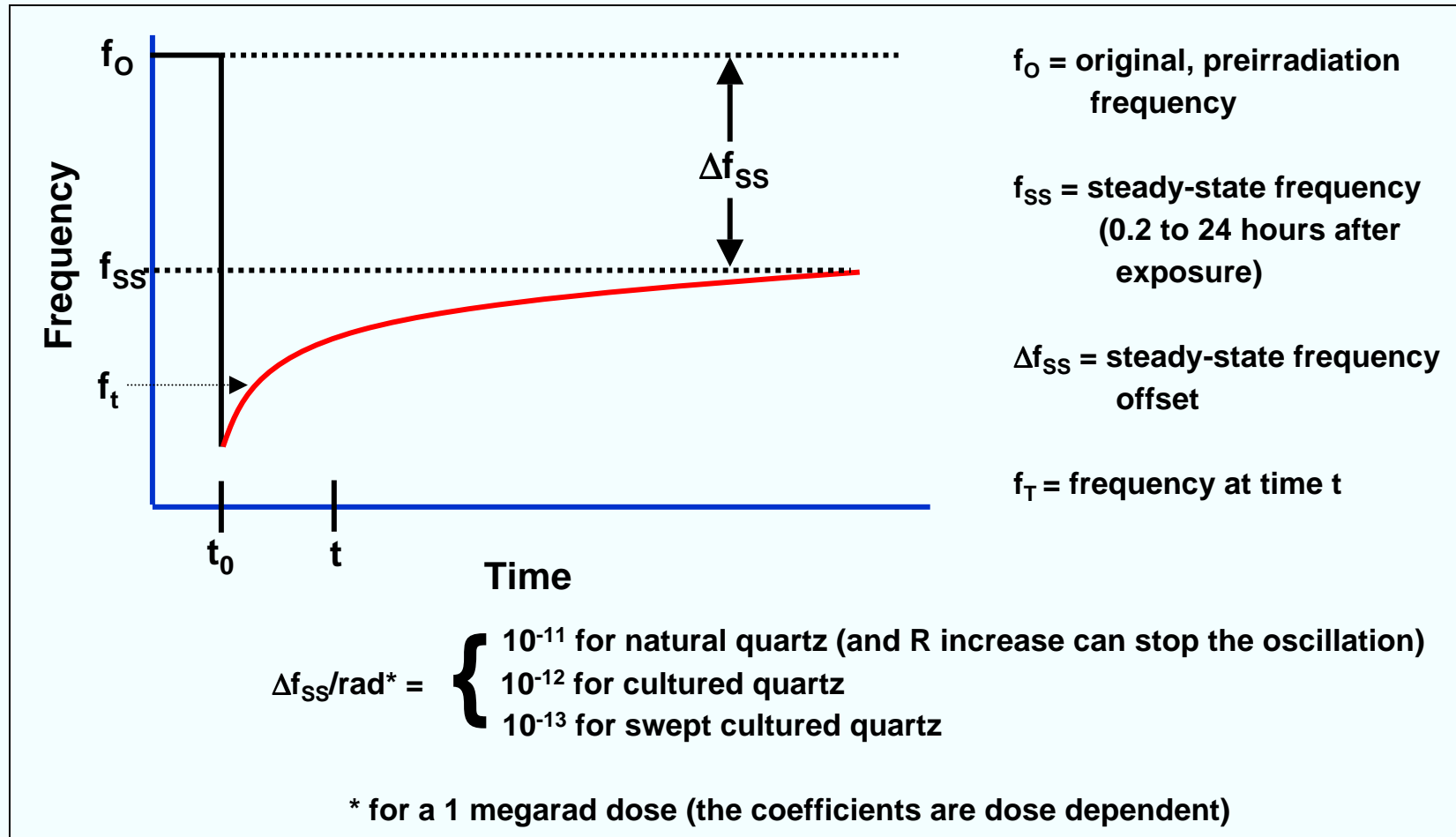

Idealized frequency vs. time behavior for a quartz resonator following a pulse of ionizing radiation.

# Effects of Repeated Radiations

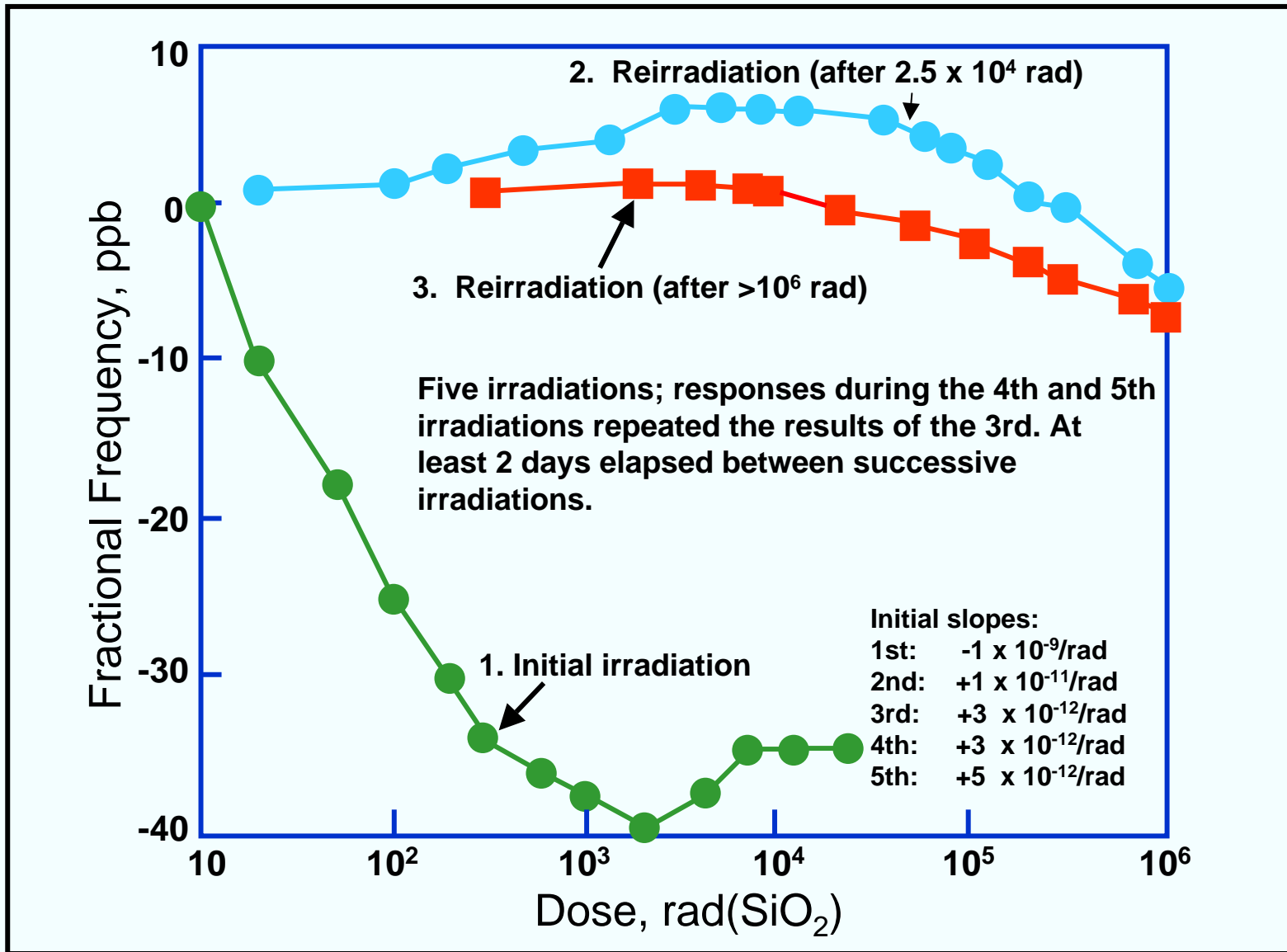

# Radiation Induced $\Delta f$ vs. Dose and Quartz Type

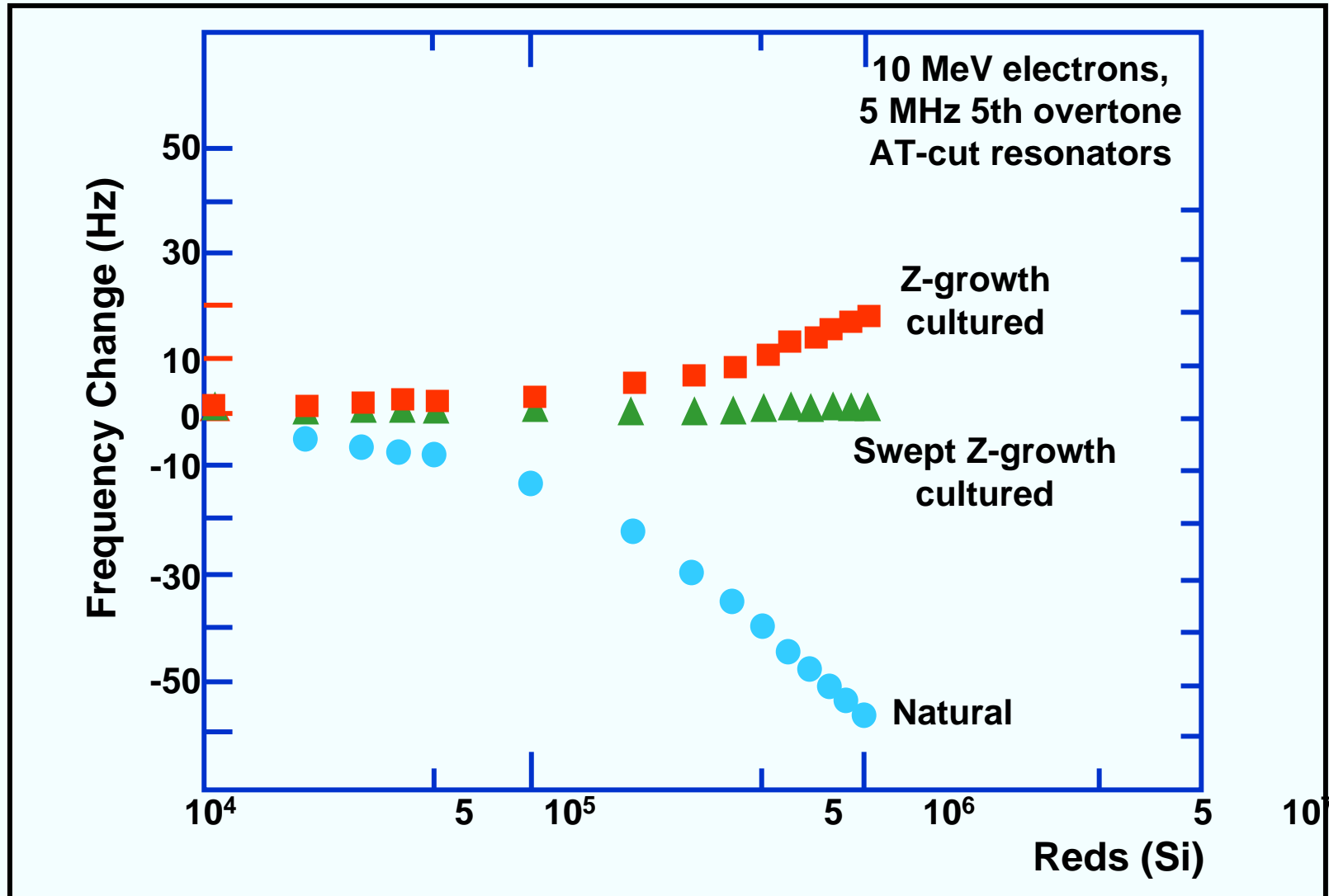

# Annealing of Radiation Induced f Changes

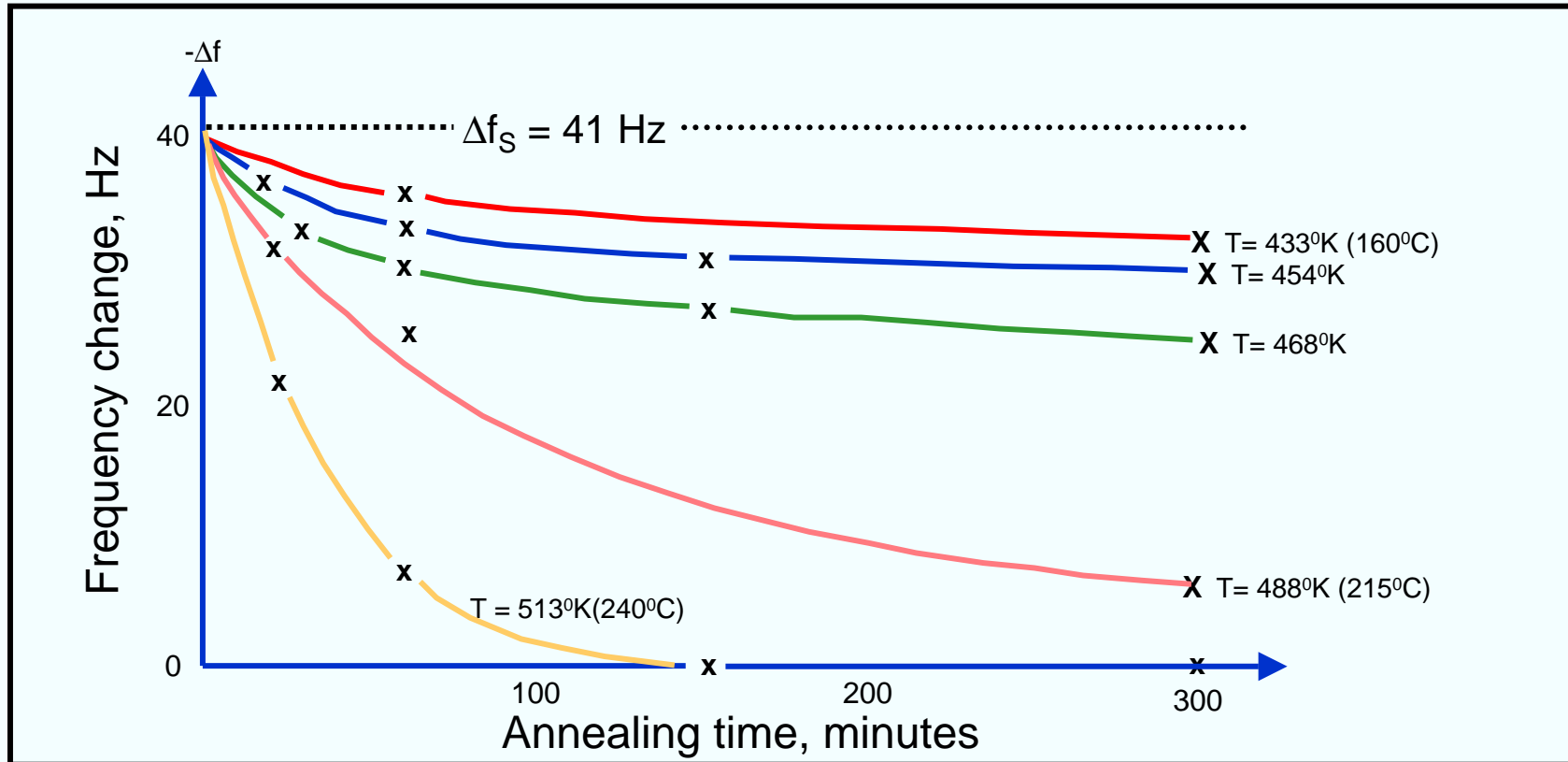

- For a 4 MHz AT-cut resonator, X-ray dose of  $6 \times 10^6$  rads produced  $\Delta f = 41$  Hz.
- Activation energies were calculated from the temperature dependence of the annealing curves. The experimental results can be reproduced by two processes, with activation energies  $E_1 = 0.3 \pm 0.1$  eV and  $E_2 = 1.3 \pm 0.3$  eV.
- Annealing was complete in less than 3 hours at  $> 240^{\circ}\text{C}$ .



# Transient $\Delta f$ After a Pulse of $\gamma$ Radiation

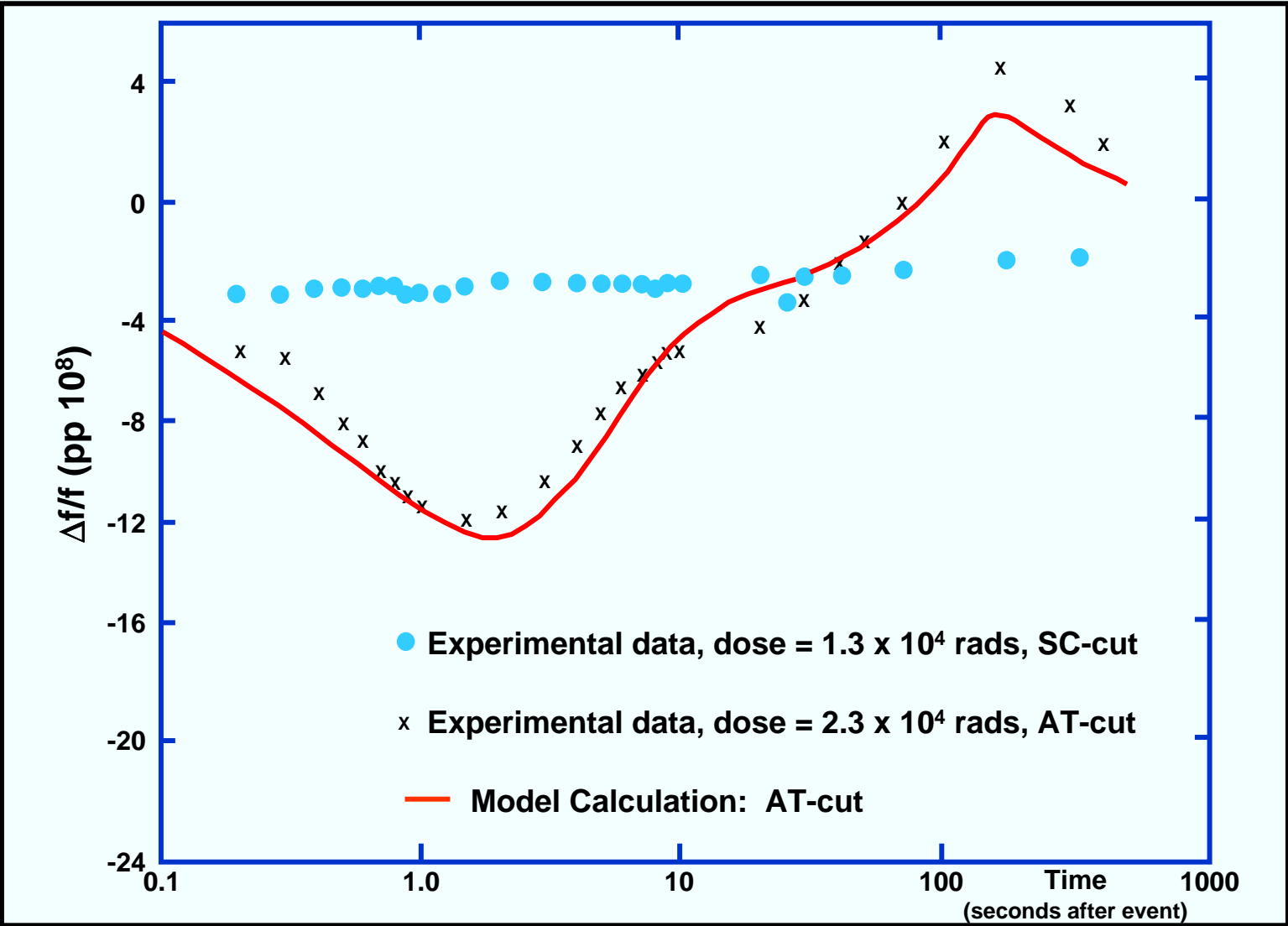

# Effects of Flash X-rays on $R_s$

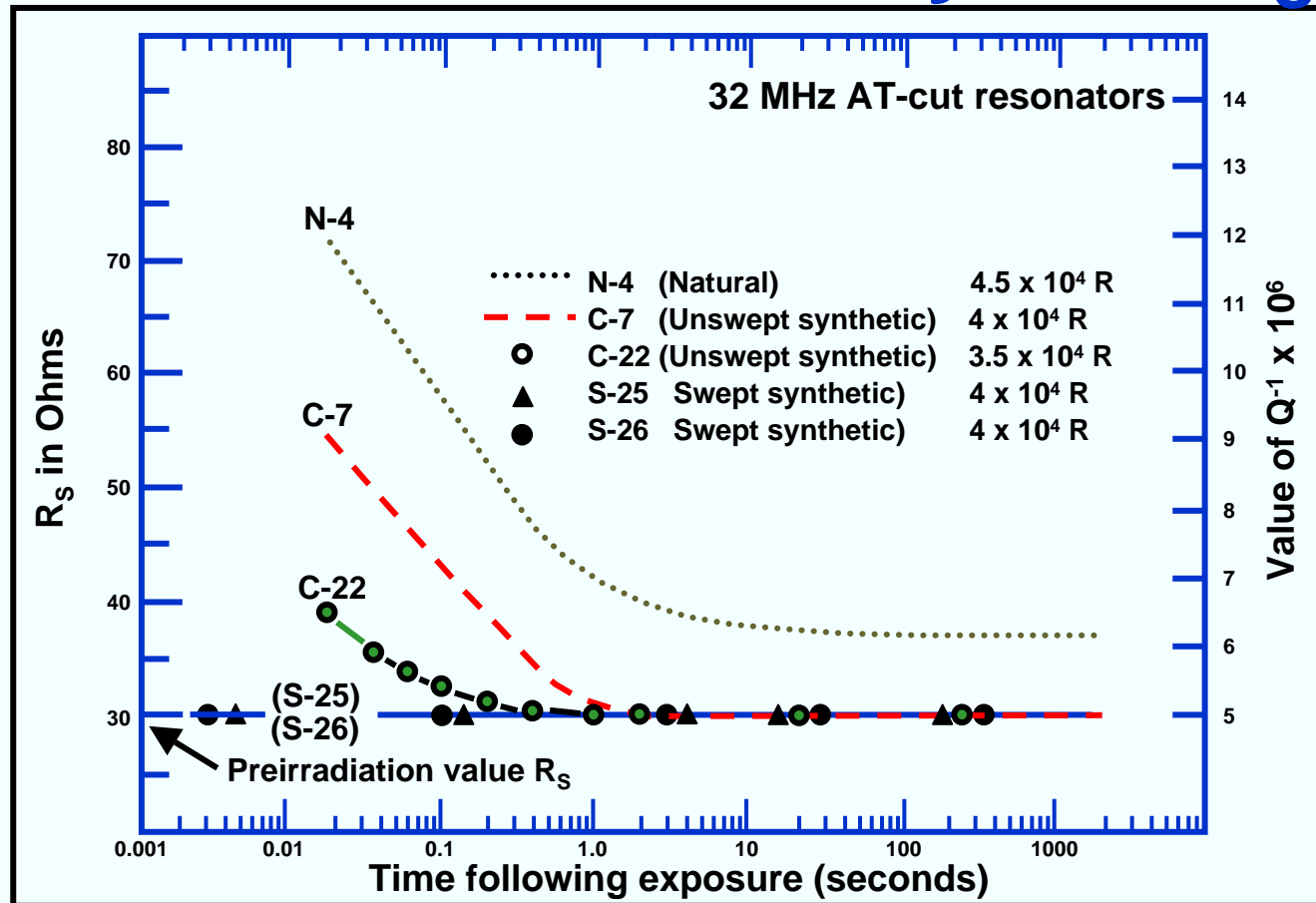

The curves show the series resonance resistance,  $R_s$ , vs. time following a  $4 \times 10^4$  rad pulse. Resonators made of swept quartz show no change in  $R_s$  from the earliest measurement time (1 ms) after exposure, at room temperature. Large increases in  $R_s$  (i.e., large decrease in the Q) will stop the oscillation.

# Frequency Change due to Neutrons

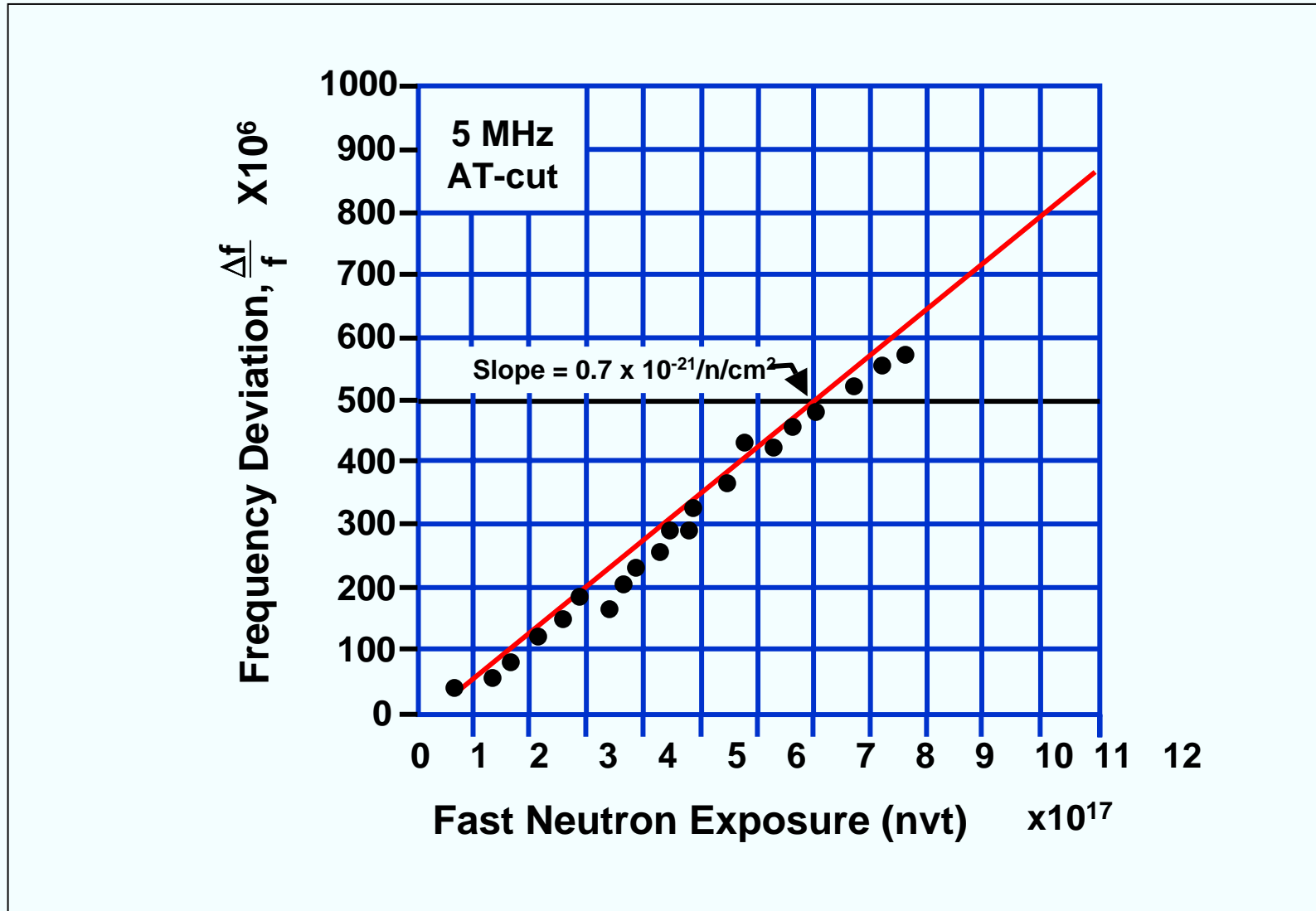

# Neutron Damage

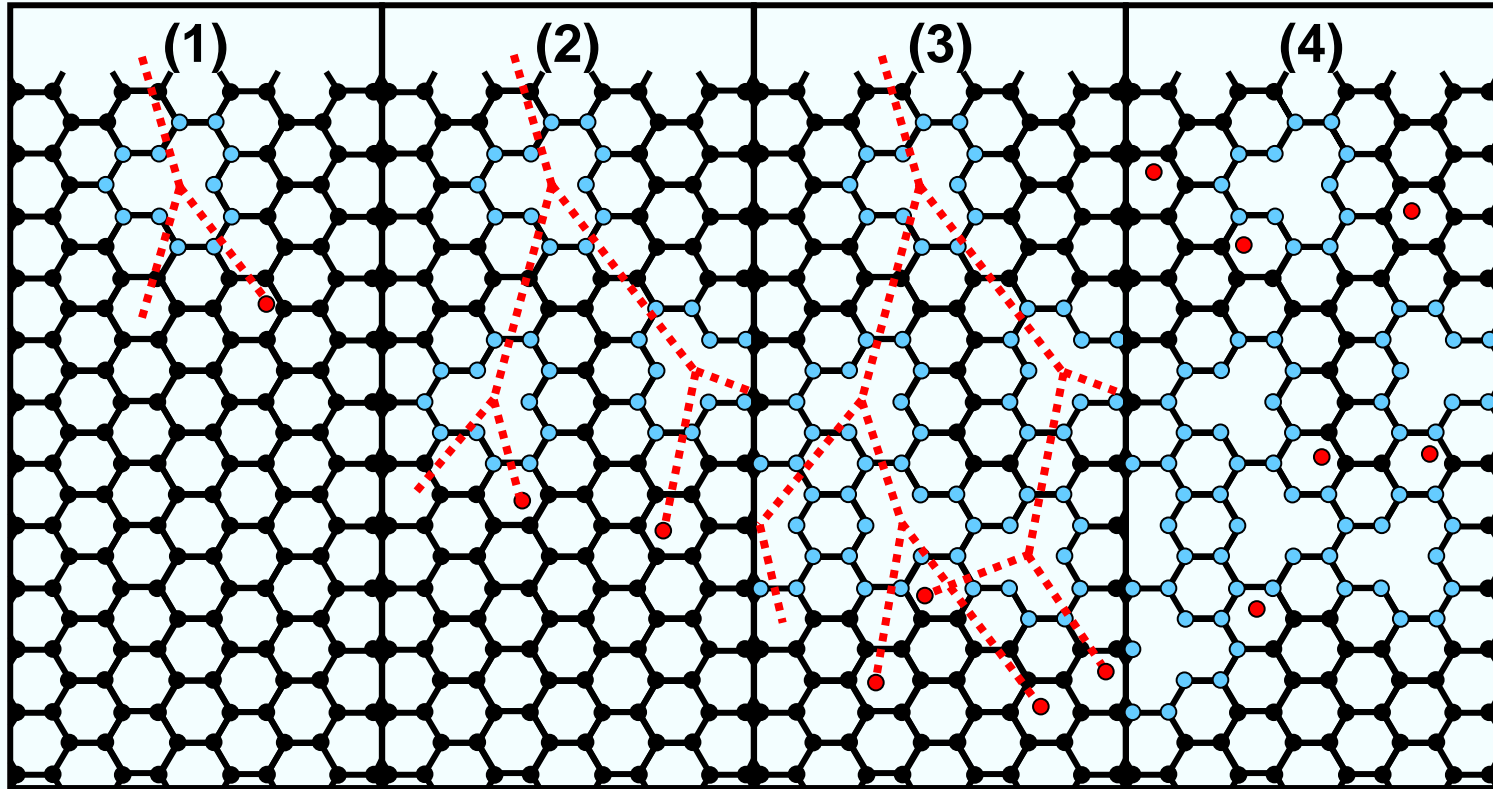

A fast neutron can displace about 50 to 100 atoms before it comes to rest. Most of the damage is done by the recoiling atoms. Net result is that each neutron can cause numerous vacancies and interstitials.

# Summary - Steady-State Radiation Results

- Dose vs. frequency change is nonlinear; frequency change per rad is larger at low doses.
- At doses > 1 kRad, frequency change is quartz-impurity dependent. The ionizing radiation produces electron-hole pairs; the holes are trapped by the impurity Al sites while the compensating cation (e.g., Li<sup>+</sup> or Na<sup>+</sup>) is released. The freed cations are loosely trapped along the optic axis. The lattice near the Al is altered, the elastic constant is changed; therefore, the frequency shifts. Ge impurity is also troublesome.
- At a 1 MRad dose, frequency change ranges from pp 10<sup>11</sup> per rad for natural quartz to pp 10<sup>14</sup> per rad for high quality swept quartz.
- Frequency change is negative for natural quartz; it can be positive or negative for cultured and swept cultured quartz.
- Frequency change saturates at doses >> 10<sup>6</sup> rads.
- Q degrades upon irradiation if the quartz contains a high concentration of alkali impurities; Q of resonators made of properly swept cultured quartz is unaffected.
- High dose radiation can also rotate the f vs. T characteristic.
- Frequency change anneals at T > 240°C in less than 3 hours.
- Preconditioning (e.g., with doses > 10<sup>5</sup> rads) reduces the high dose radiation sensitivities upon subsequent irradiations.
- At < 100 rad, frequency change is not well understood. Radiation induced stress relief & surface effects (adsorption, desorption, dissociation, polymerization and charging) may be factors.

# Summary - Pulse Irradiation Results

- For applications requiring circuits hardened to pulse irradiation, quartz resonators are the least tolerant element in properly designed oscillator circuits.
- Resonators made of unswept quartz or natural quartz can experience a large increase in  $R_s$  following a pulse of radiation. The radiation pulse can stop the oscillation.
- Natural, cultured, and swept cultured AT-cut quartz resonators experience an initial negative frequency shift immediately after exposure to a pulse of X-rays (e.g.,  $10^4$  to  $10^5$  Rad of flash X-rays),  $\Delta f/f$  is as large as -3ppm at 0.02sec after burst of  $10^{12}$  Rad/sec.
- Transient  $f$  offset anneals as  $t^{1/2}$ ; the nonthermal-transient part of the  $f$  offset is probably due to the diffusion and retrapping of hydrogen at the  $Al^{3+}$  trap.
- Resonators made of properly swept quartz experience a negligibly small change in  $R_s$  when subjected to pulsed ionizing radiation (therefore, the oscillator circuit does not require a large reserve of gain margin).
- SC-cut quartz resonators made of properly swept high Q quartz do not exhibit transient frequency offsets following a pulse of ionizing radiation.
- Crystal oscillators will stop oscillating during an intense pulse of ionizing radiation because of the large prompt photoconductivity in quartz and in the transistors comprising the oscillator circuit. Oscillation will start up within  $15\mu\text{sec}$  after a burst if swept quartz is used in the resonator and the oscillator circuit is properly designed for the radiation environment.

# Summary - Neutron Irradiation Results

- When a fast neutron (~MeV energy) hurtles into a crystal lattice and collides with an atom, it is scattered like a billiard ball. The recoiling atom, having an energy ( $\sim 10^4$  to  $10^6$  eV) that is much greater than its binding energy in the lattice, leaves behind a vacancy and, as it travels through the lattice, it displaces and ionizes other atoms. A single fast neutron can thereby produce numerous vacancies, interstitials, and broken interatomic bonds. Neutron damage thus changes both the elastic constants and the density of quartz. Of the fast neutrons that impinge on a resonator, most pass through without any collisions, i.e., without any effects on the resonator. The small fraction of neutrons that collide with atoms in the lattice cause the damage.
- Frequency increases approximately linearly with fluence. For AT- and SC-cut resonators, the slopes range from  $+0.7 \times 10^{-21}/\text{n}/\text{cm}^2$ , at very high fluences ( $10^{17}$  to  $10^{18}\text{n}/\text{cm}^2$ ) to  $5 \times 10^{-21}/\text{n}/\text{cm}^2$  at  $10^{12}$  to  $10^{13}\text{n}/\text{cm}^2$ , and  $8 \times 10^{-21}/\text{n}/\text{cm}^2$  at  $10^{10}$  to  $10^{12}\text{n}/\text{cm}^2$ . Sensitivity probably depends somewhat on the quartz defect density and on the neutron energy distribution. (Thermonuclear neutrons cause more damage than reactor neutrons.)
- Neutron irradiation also rotates the frequency vs. temperature characteristic.
- When a heavily neutron irradiated sample was baked at  $500^\circ\text{C}$  for six days, 90% of the neutron-induced frequency shift was removed (but the 10% remaining was still 93 ppm).

# Other Effects on Stability

- **Electric field** - affects doubly-rotated resonators; e.g., a voltage on the electrodes of a 5 MHz fundamental mode SC-cut resonator results in a  $\Delta f/f = 7 \times 10^{-9}$  per volt. The voltage can also cause sweeping, which can affect the frequency (of all cuts), even at normal operating temperatures.
- **Magnetic field** - quartz is diamagnetic, however, magnetic fields can induce Eddy currents, and will affect magnetic materials in the resonator package and the oscillator circuitry. Induced ac voltages can affect varactors, AGC circuits and power supplies. Typical frequency change of a "good" quartz oscillator is  $\ll 10^{-10}$  per gauss.
- **Ambient pressure (altitude)** - deformation of resonator and oscillator packages, and change in heat transfer conditions affect the frequency.
- **Humidity** - can affect the oscillator circuitry, and the oscillator's thermal properties, e.g., moisture absorbed by organics can affect dielectric constants.
- **Power supply voltage, and load impedance** - affect the oscillator circuitry, and indirectly, the resonator's drive level and load reactance. A change in load impedance changes the amplitude or phase of the signal reflected into the oscillator loop, which changes the phase (and frequency) of the oscillation. The effects can be minimized by using a (low noise) voltage regulator and buffer amplifier.
- **Gas permeation** - stability can be affected by excessive levels of atmospheric hydrogen and helium diffusing into "hermetically sealed" metal and glass enclosures (e.g., hydrogen diffusion through nickel resonator enclosures, and helium diffusion through glass Rb standard bulbs).



# Interactions Among Influences

In attempting to measure the effect of a single influence, one often encounters interfering influences, the presence of which may or may not be obvious.

<b>Measurement</b>	<b>Interfering Influence</b>
Resonator aging	$\Delta T$ due to oven T (i.e., thermistor) aging $\Delta$ drive level due to osc. circuit aging
Short term stability	Vibration
Vibration sensitivity	Induced voltages due to magnetic fields
2-g tipover sensitivity	$\Delta T$ due to convection inside oven
Resonator f vs. T (static)	Thermal transient effect, humidity T-coefficient of load reactances
Radiation sensitivity	$\Delta T$ , thermal transient effect, aging

**CHAPTER 5**  
**Quartz Material Properties**

# Hydrothermal Growth of Quartz

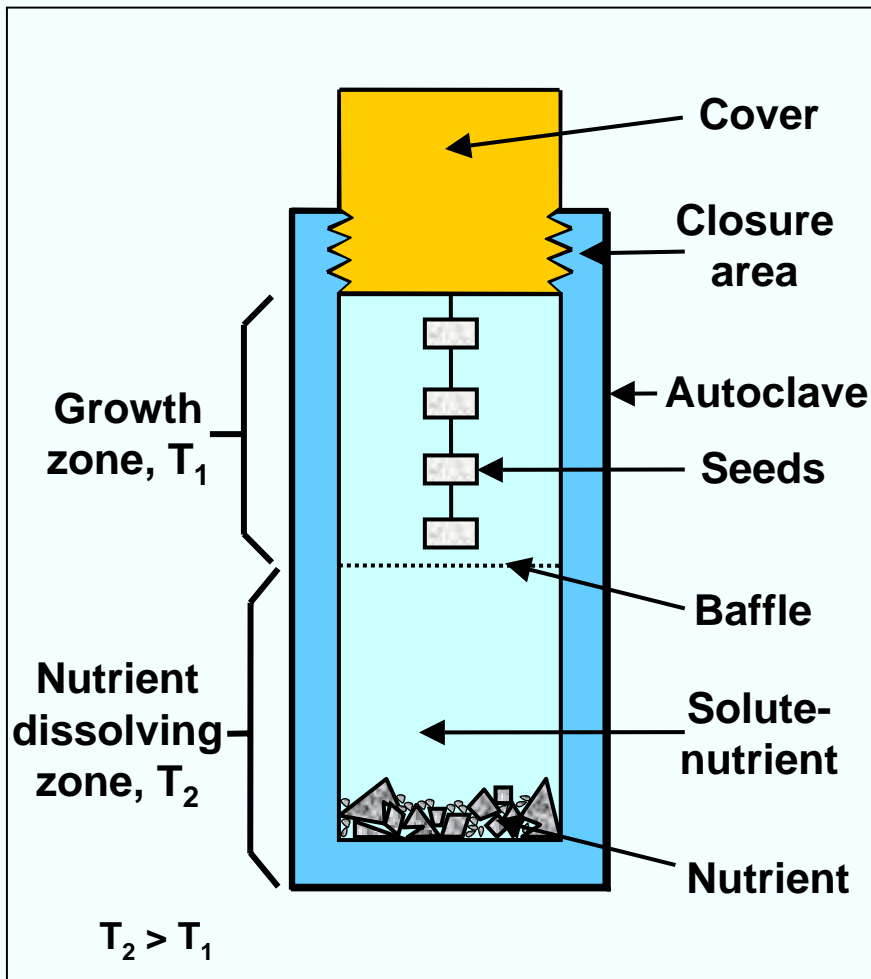

- The autoclave is filled to some predetermined factor with water plus mineralizer ( $\text{NaOH}$  or  $\text{Na}_2\text{CO}_3$ ).
- The baffle localizes the temperature gradient so that each zone is nearly isothermal.
- The seeds are thin slices of (usually) Z-cut single crystals.
- The nutrient consists of small ( $\sim 2\frac{1}{2}$  to 4 cm) pieces of single-crystal quartz ("lascas").
- The temperatures and pressures are typically about  $350^\circ\text{C}$  and 800 to 2,000 atmospheres;  $T_2 - T_1$  is typically  $4^\circ\text{C}$  to  $10^\circ\text{C}$ .
- The nutrient dissolves slowly (30 to 260 days per run), diffuses to the growth zone, and deposits onto the seeds.

# Deeply Dissolved Quartz Sphere

Anisotropic Etching

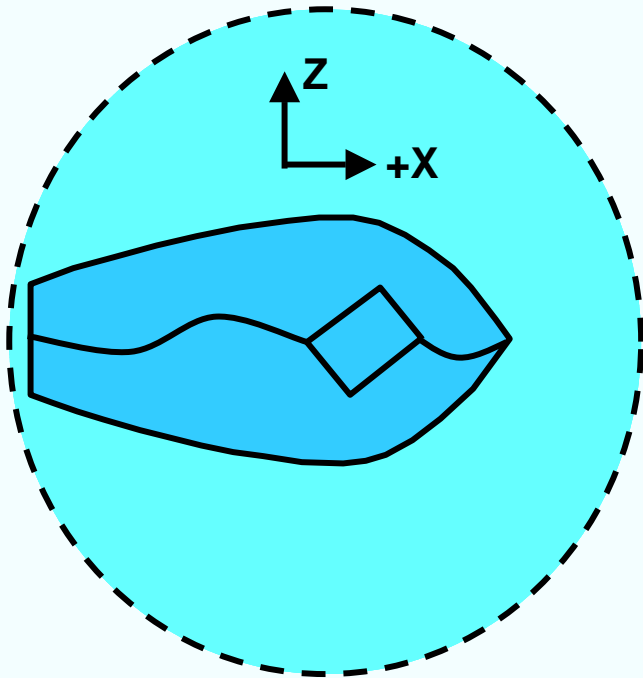

Looking along Y-axis

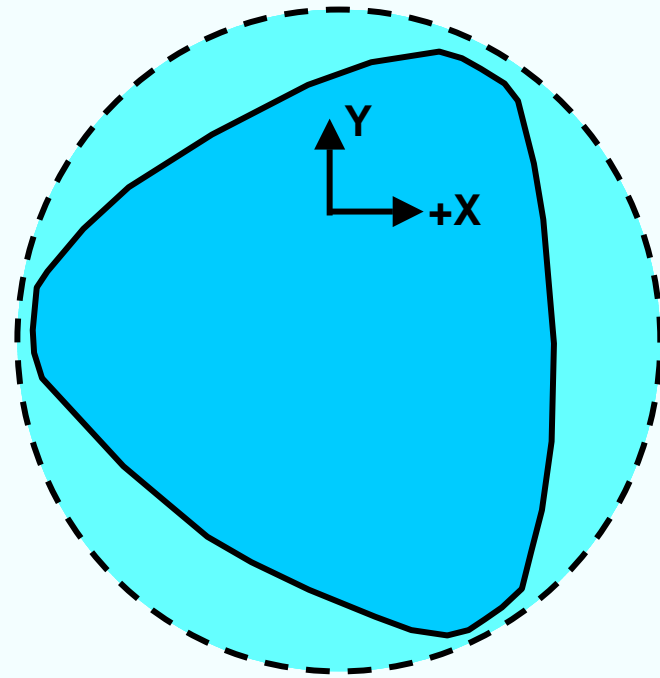

Looking along Z-axis

# Etching & Chemical Polishing

## Etchant Must:

1. Diffuse to Surface
2. Be Adsorbed
3. React Chemically

## Reaction Products Must:

4. Be Desorbed
5. Diffuse Away

## Diffusion Controlled Etching:

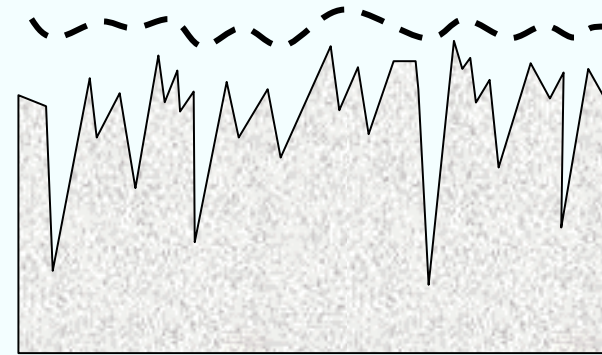

**Lapped surface**



**Chemically polished surface**

# Left-Handed and Right-Handed Quartz

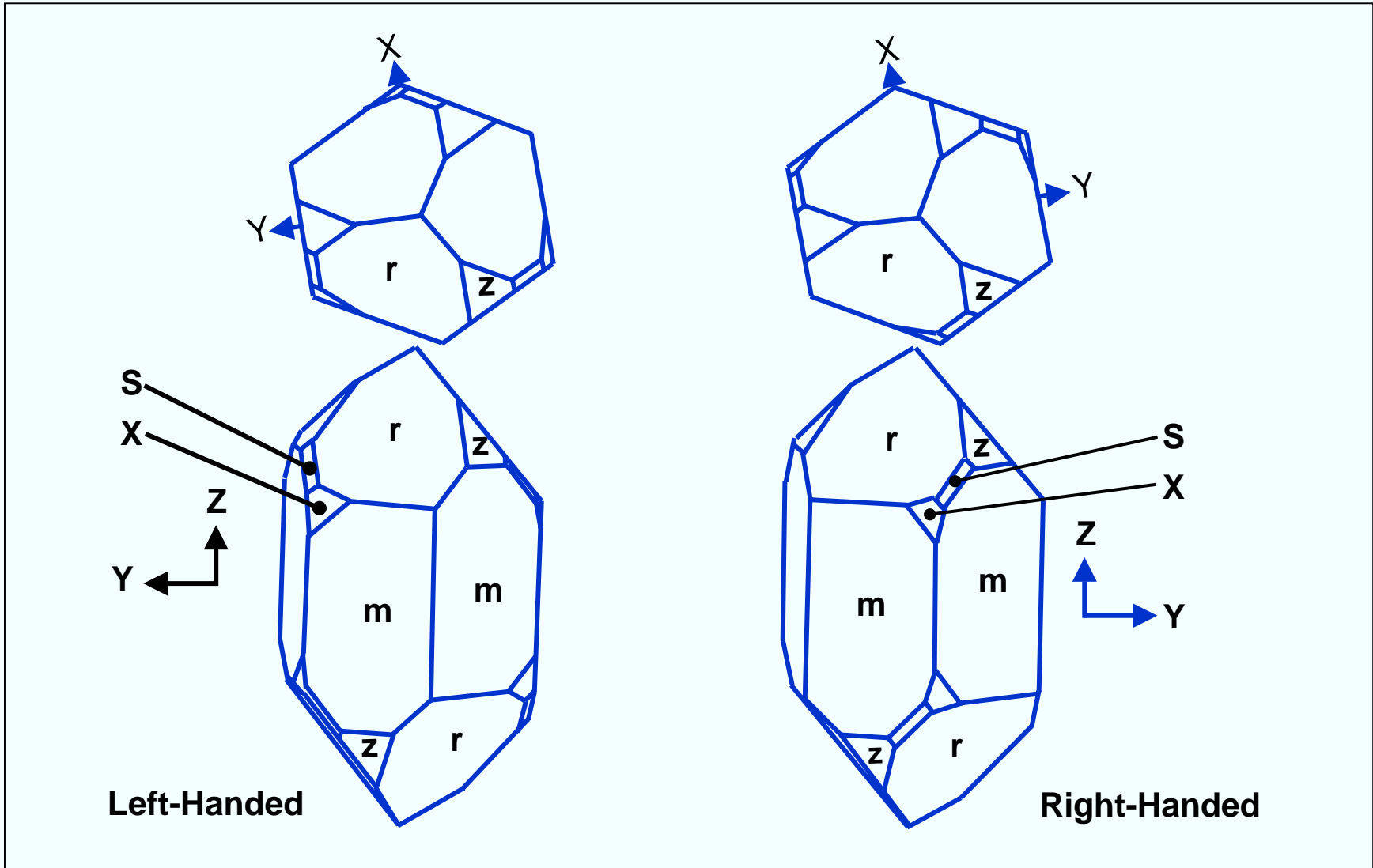

# The Quartz Lattice

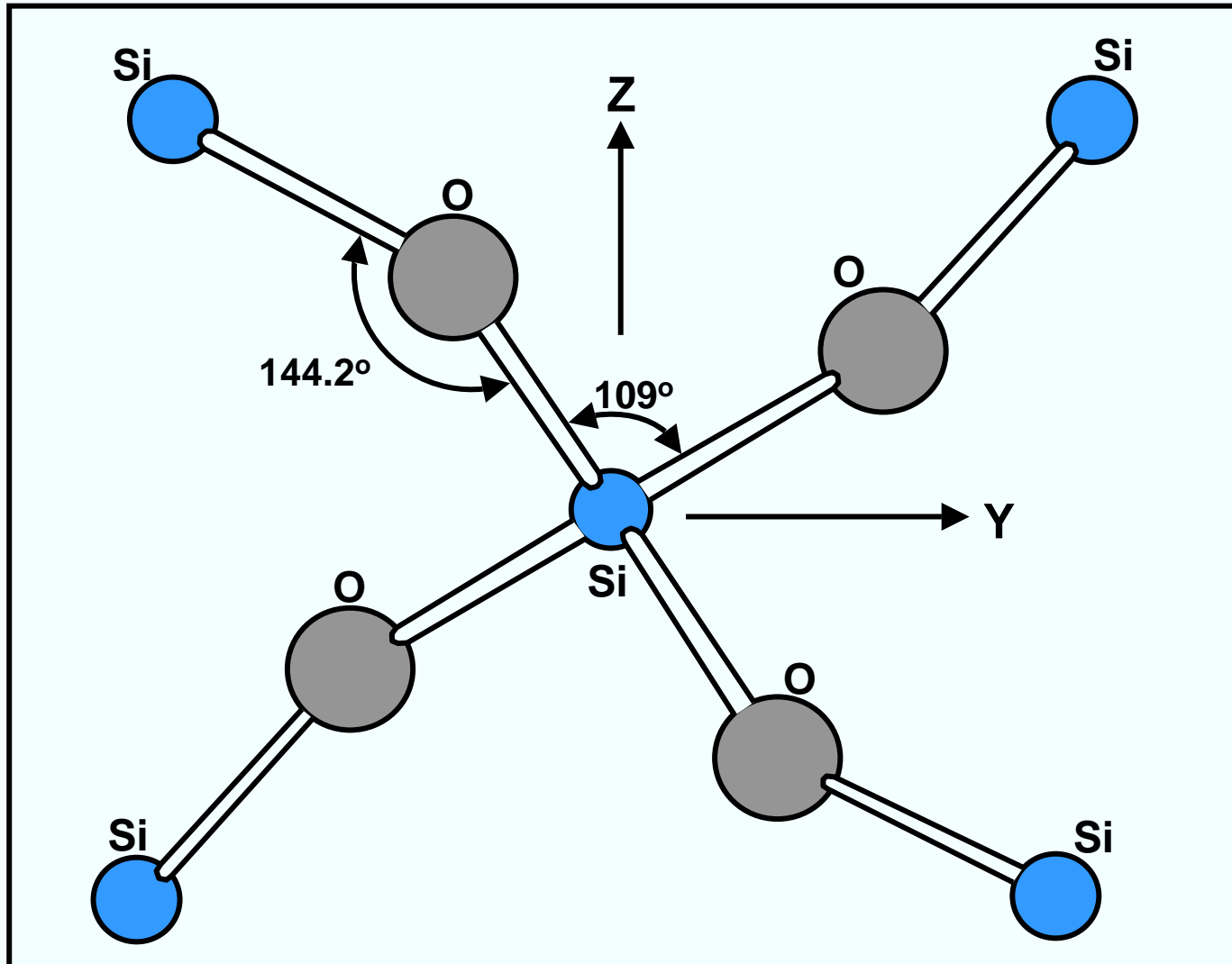

# Quartz Properties' Effects on Device Properties

<b>Quartz Property</b>	<b>Device and Device-Fabrication Property</b>
<b>Q</b>	Oscillator short-term stability, phase noise close to carrier, long-term stability, filter loss
<b>Purity (Al, Fe, Li, Na, K, -OH, H<sub>2</sub>O)</b>	Radiation hardness, susceptibility to twinning, optical characteristics
<b>Crystalline Perfection, Strains</b>	Sweepability, etchability for chem. polishing and photolithographic processing, optical properties, strength, aging(?), hysteresis(?)
<b>Inclusions</b>	High-temperature processing and applications, resonator Q, optical characteristics, etchability



# Ions in Quartz - Simplified Model

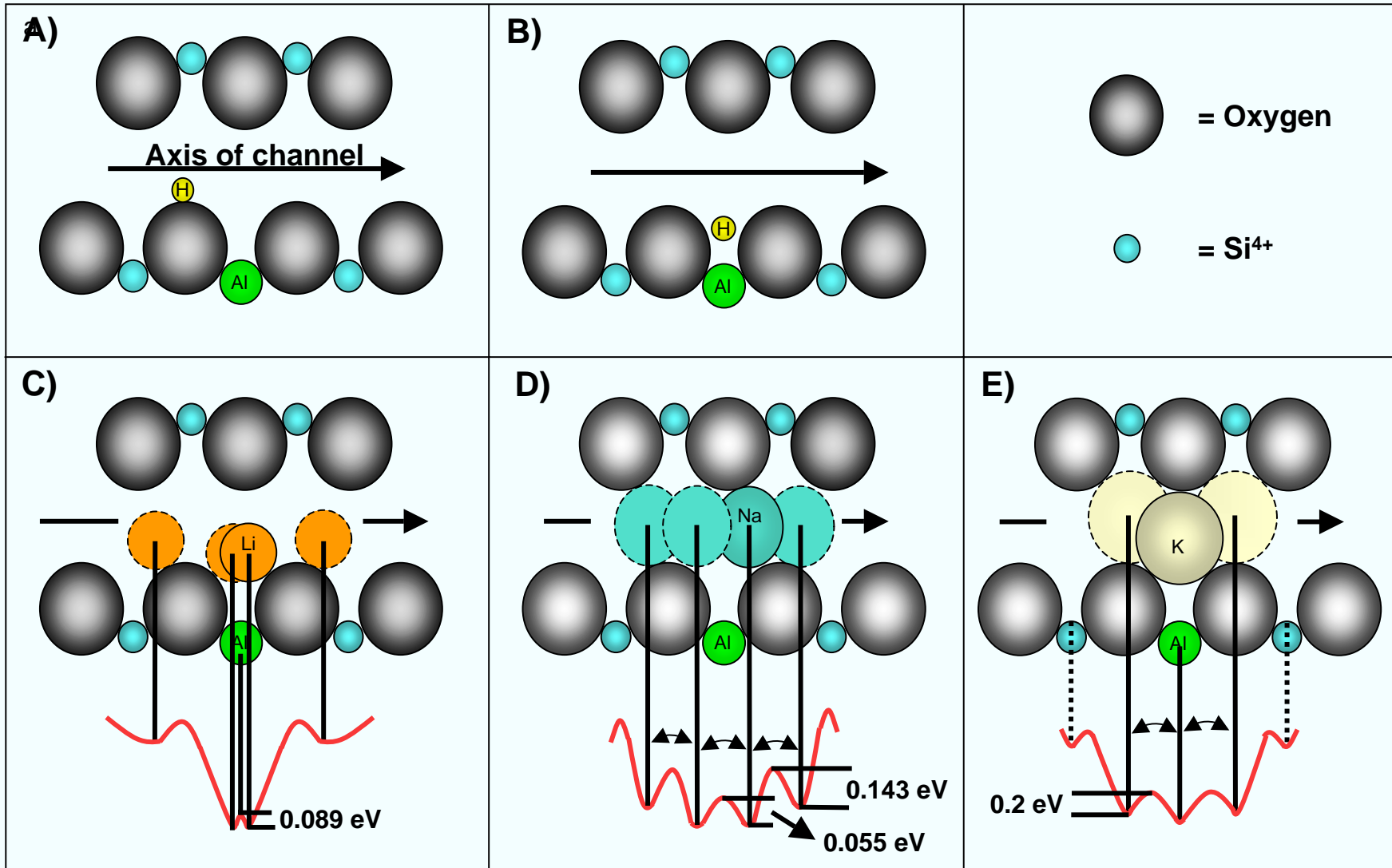

# Aluminum Associated Defects

**Al-OH center**

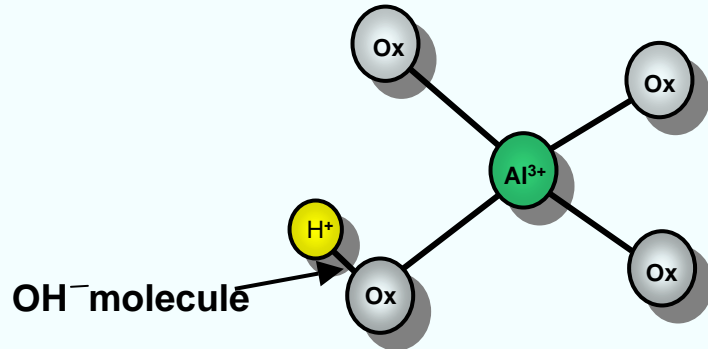

**Al-M<sup>+</sup> center**

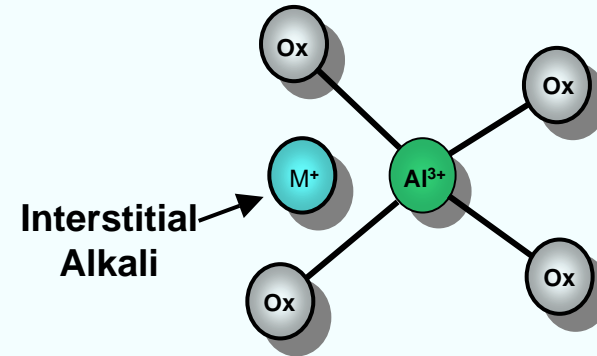

**Al-hole center**

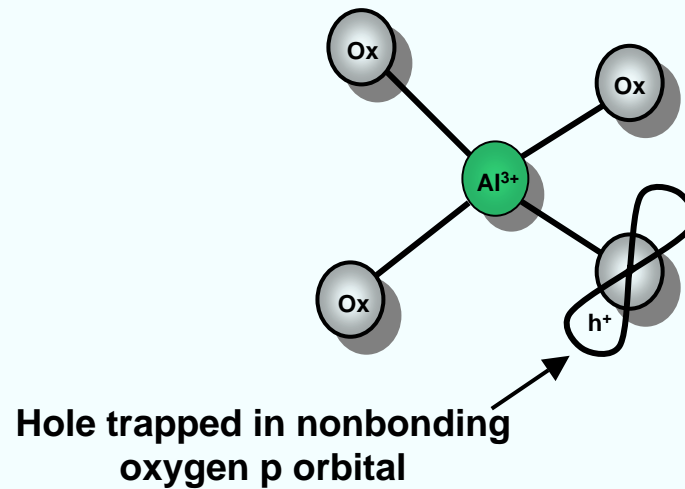

# Sweeping

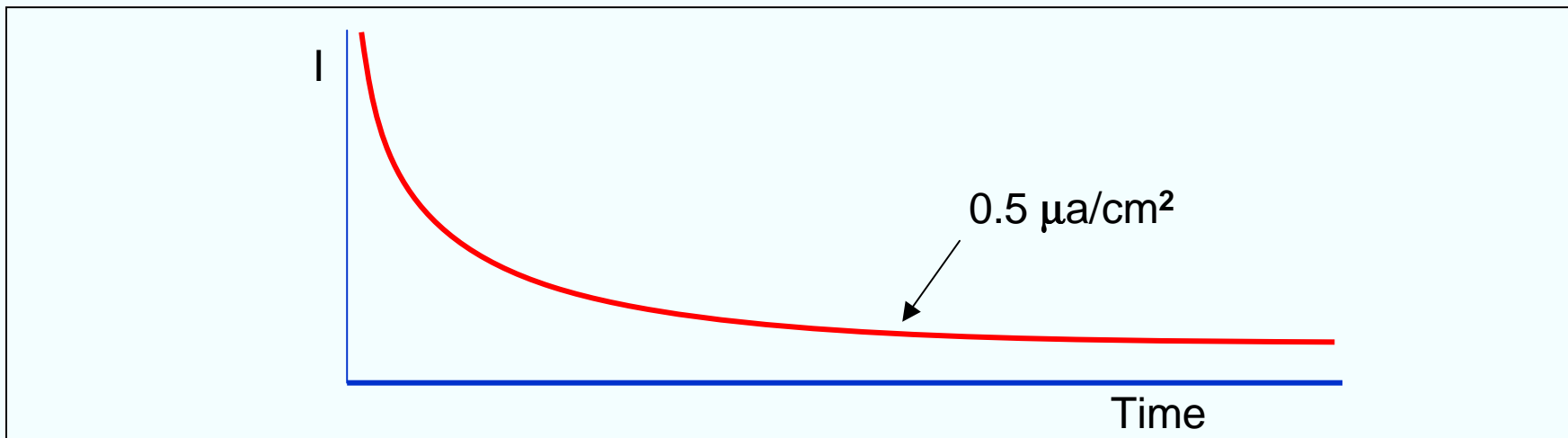
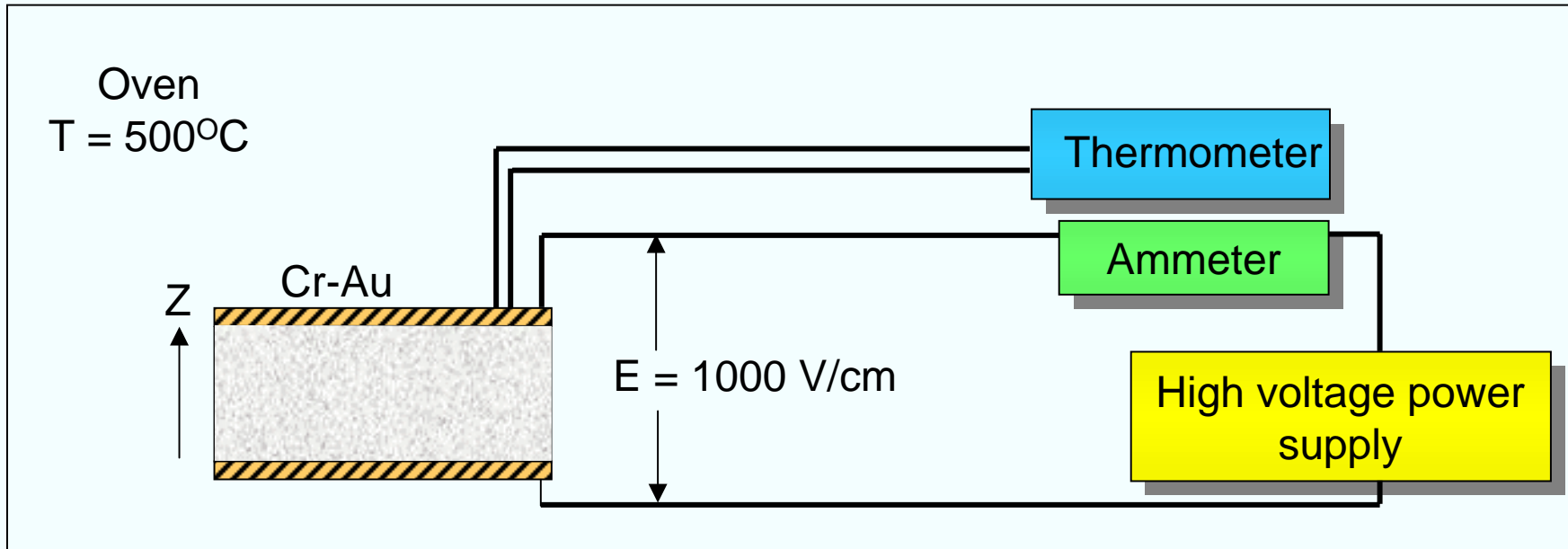

# Quartz Quality Indicators

- Infrared absorption coefficient\*
- Etch-channel density \*
- Etch-pit density
- Inclusion density \*
- Acoustic attenuation
- Impurity analysis
- X-ray topography
- UV absorption
- Birefringence along the optic axis
- Thermal shock induced fracture
- Electron spin resonance
- ? ? ?

\* EIA Standard 477-1 contains standard test method for this quantity

# Infrared Absorption of Quartz

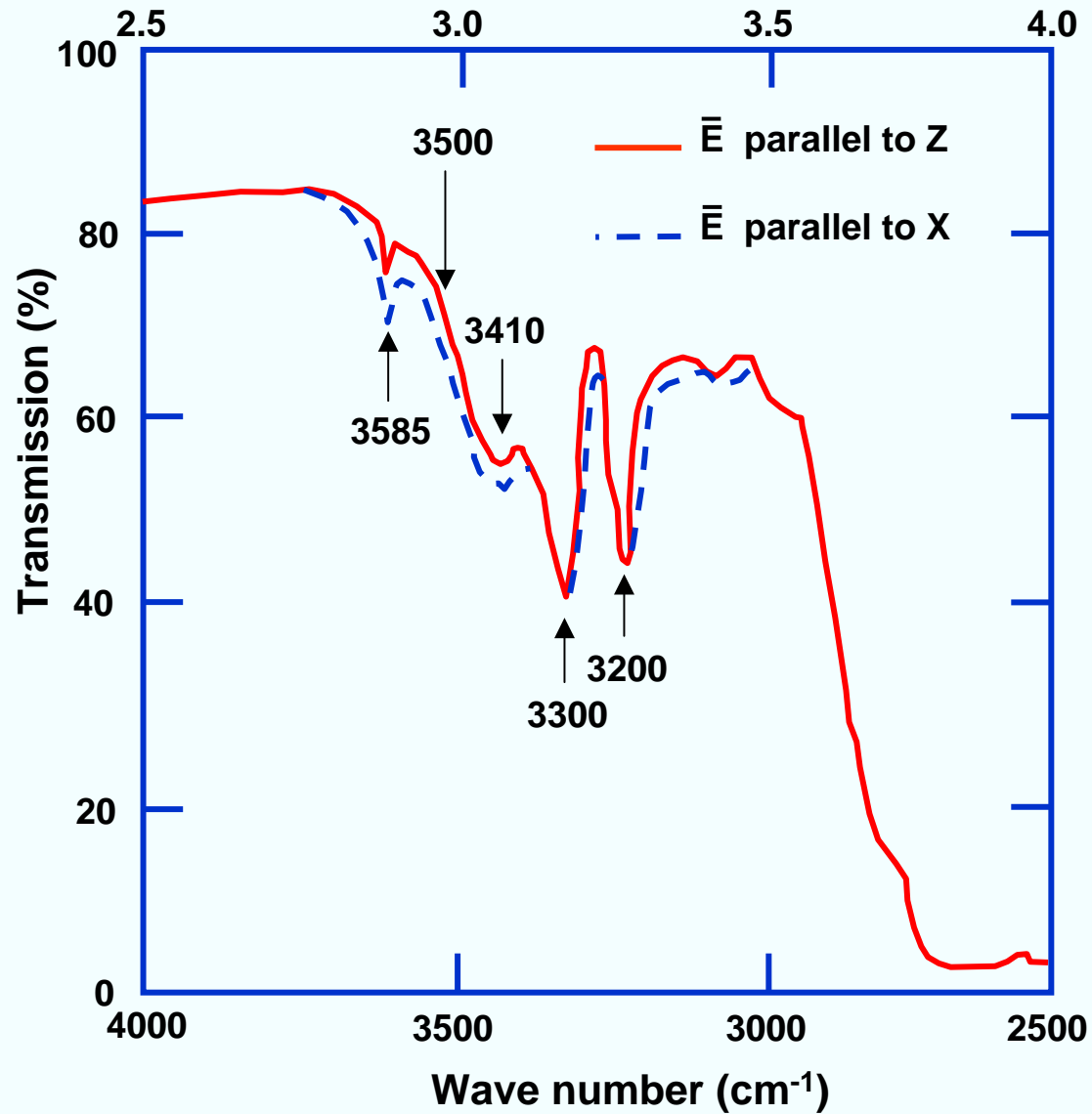

# Infrared Absorption Coefficient

One of the factors that determine the maximum achievable resonator Q is the OH content of the quartz. Infrared absorption measurements are routinely used to measure the intensities of the temperature-broadened OH defect bands. The **infrared absorption coefficient**  $\alpha$  is defined by EIA Standard 477-1 as

$$\alpha = \frac{A(3500 \text{ cm}^{-1}) - A(3800 \text{ cm}^{-1})}{\text{Y-cut thickness in cm}}$$

where the A's are the logarithm (base 10) of the fraction of the incident beam absorbed at the wave numbers in the parentheses.

<b>Grade</b>	<b><math>\alpha</math>, in <math>\text{cm}^{-1}</math></b>	<b>Approx. max. Q*</b>
<b>A</b>	<b>0.03</b>	<b>3.0</b>
<b>B</b>	<b>0.045</b>	<b>2.2</b>
<b>C</b>	<b>0.060</b>	<b>1.8</b>
<b>D</b>	<b>0.12</b>	<b>1.0</b>
<b>E</b>	<b>0.25</b>	<b>0.5</b>

\* In millions, at 5 MHz ( $\alpha$  is a quality indicator for unswept quartz only).

# Quartz Twinning

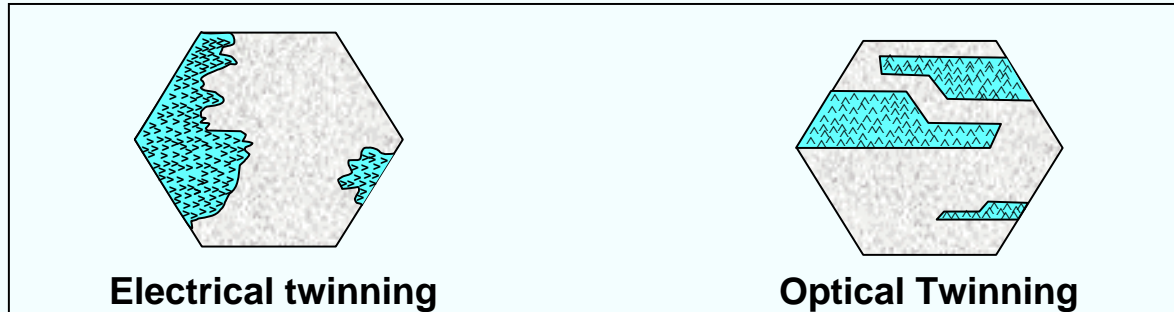

- The X-axes of quartz, the electrical axes, are parallel to the line bisecting adjacent prism faces; the +X-direction is positive upon extension due to tension.
- Electric twinning (also called Dauphiné twinning) consists of localized reversal of the X-axes. It usually consists of irregular patches, with irregular boundaries. It can be produced artificially by inversion from high quartz, thermal shock, high local pressure (even at room temperature), and by an intense electric field.
- In right-handed quartz, the plane of polarization is rotated clockwise as seen by looking toward the light source; in left handed, it is counterclockwise. Optically twinned (also called Brazil twinned) quartz contains both left and right-handed quartz. Boundaries between optical twins are usually straight.
- Etching can reveal both kinds of twinning.

# Twinning - Axial Relationships

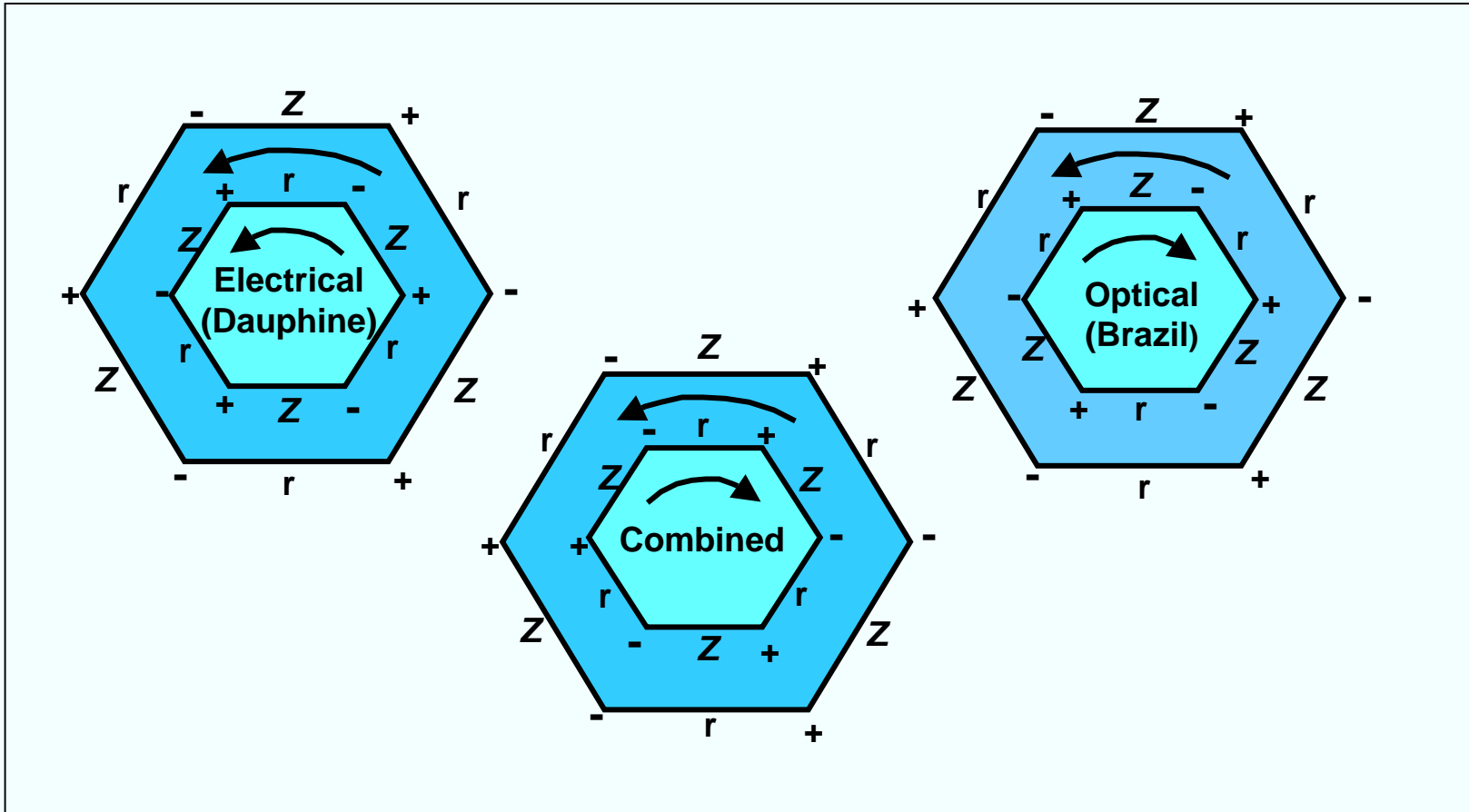

The diagrams illustrate the relationship between the axial system and hand of twinned crystals. The arrows indicate the hand.



# Quartz Lattice and Twinning

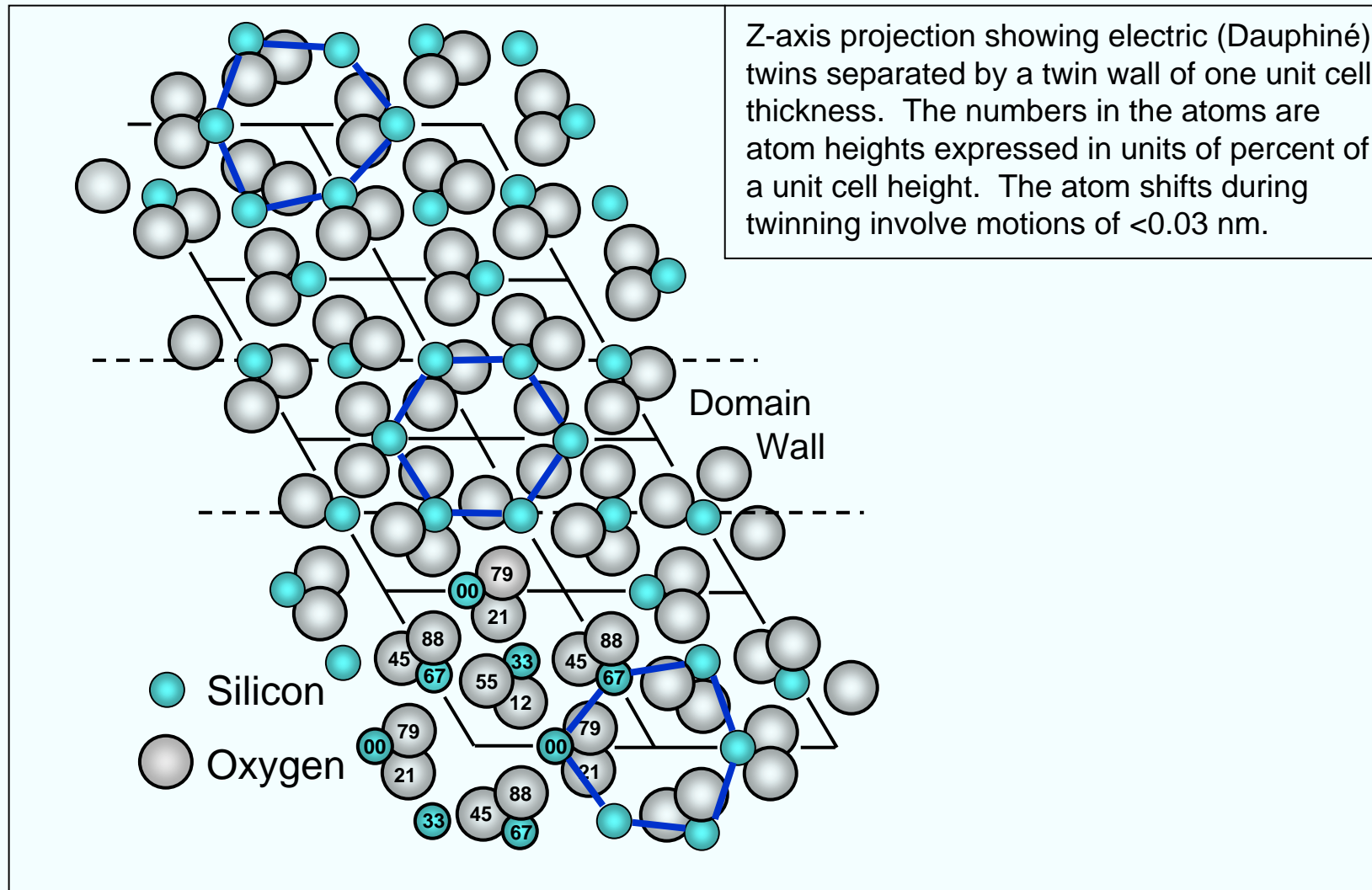

# Quartz Inversion

- Quartz undergoes a high-low inversion ( $\alpha$  -  $\beta$  transformation) at 573°C. (It is 573°C at 1 atm on rising temperature; it can be 1° to 2°C lower on falling temperature.)
- Bond angles between adjoining ( $\text{SiO}_4$ ) tetrahedra change at the inversion. Whereas low-quartz ( $\alpha$ -quartz) is trigonal, high quartz ( $\beta$  -quartz) is hexagonal. Both forms are piezoelectric.
- An abrupt change in nearly all physical properties takes place at the inversion point; volume increases by 0.86% during inversion from low to high quartz. The changes are reversible, although Dauphiné twinning is usually acquired upon cooling through the inversion point.
- Inversion temperature decreases with increasing Al and alkali content, increases with Ge content, and increases 1°C for each 40 atm increase in hydrostatic pressure.

# Phase Diagram of Silica ( $\text{SiO}_2$ )

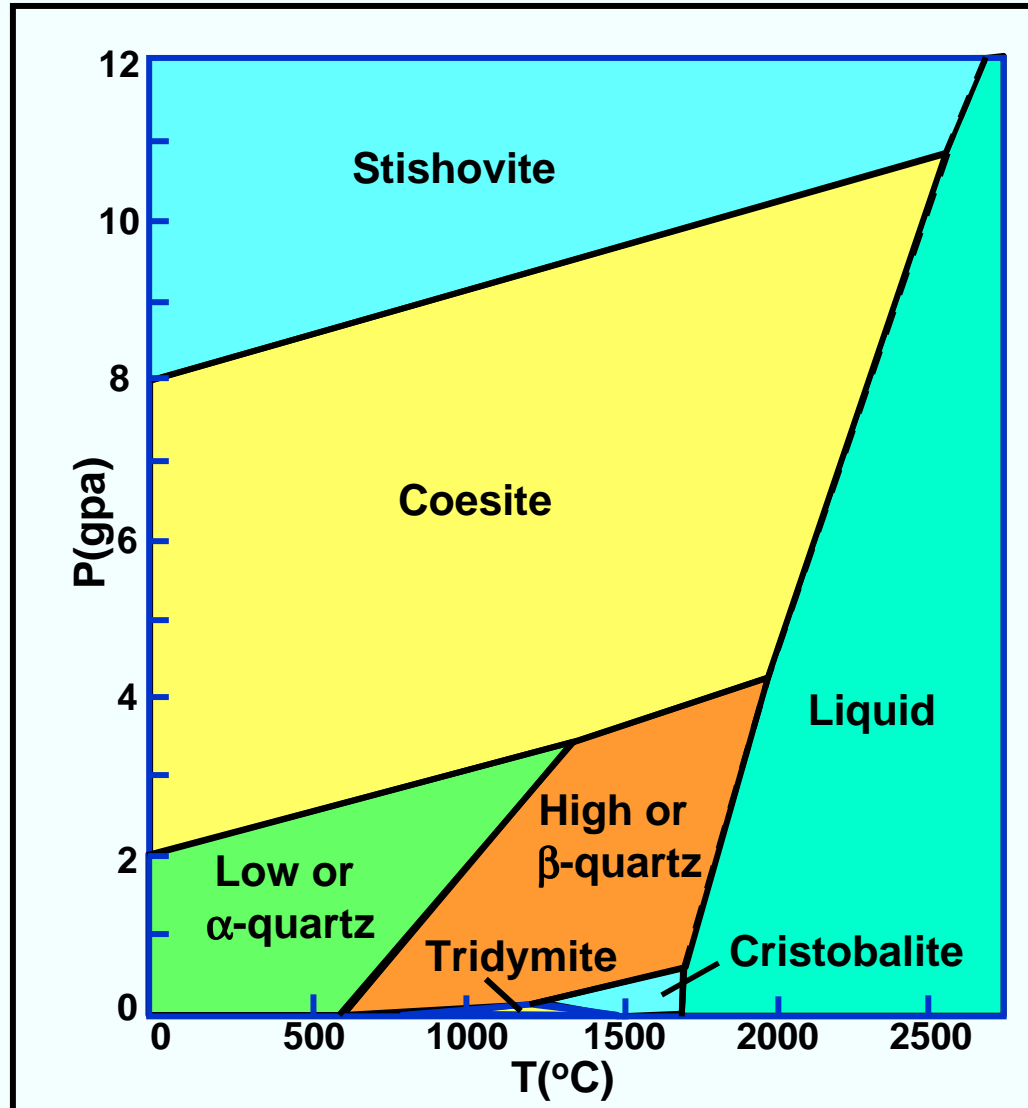

# Internal Friction of Quartz

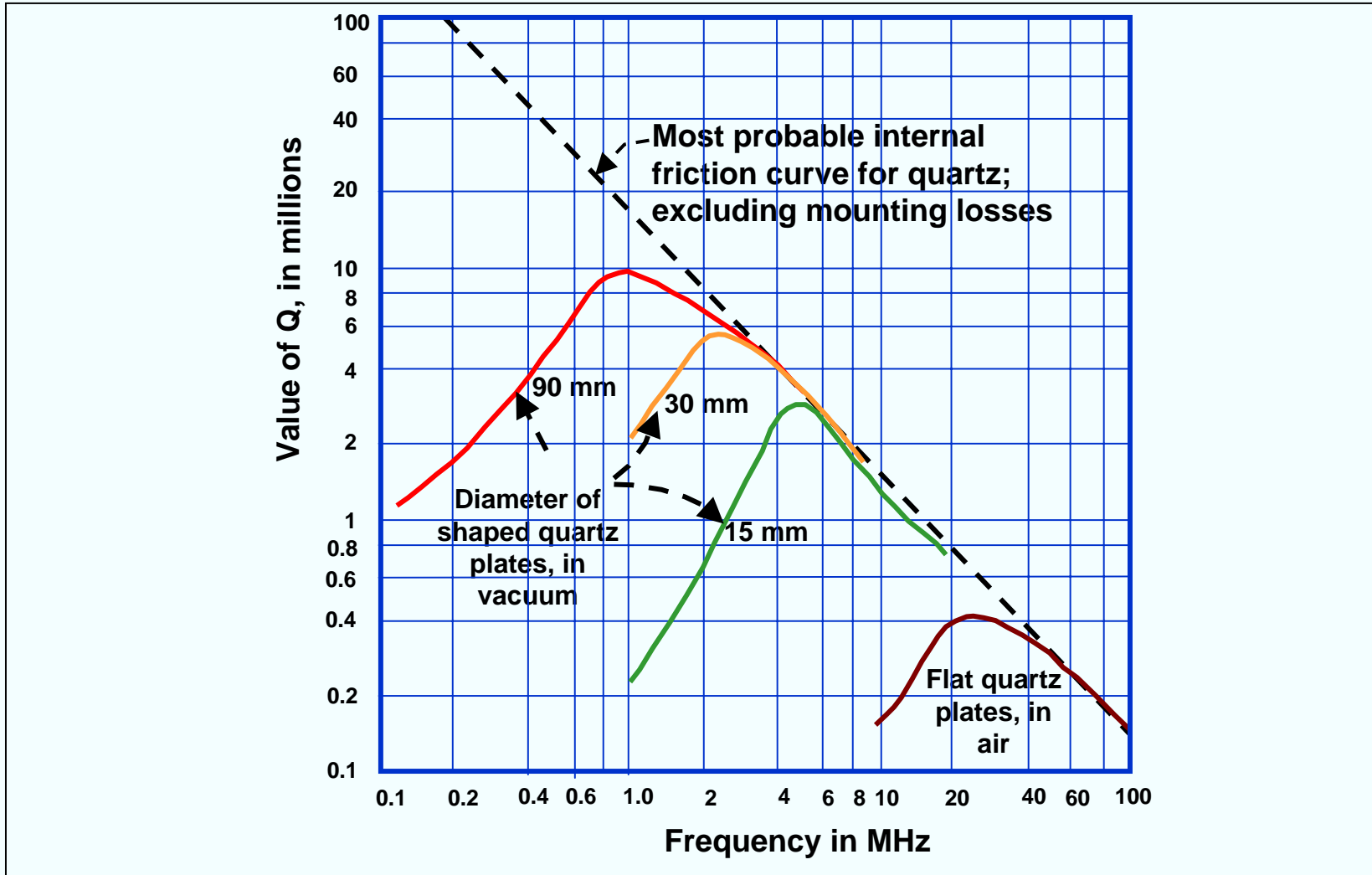

Empirically determined Q vs. frequency curves indicate that the maximum achievable Q times the frequency is a constant, e.g., 16 million for AT-cut resonators, when f is in MHz.

# Langasite and Its Isomorphs

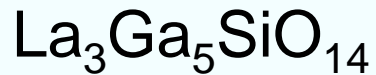

Langassite (LGS)

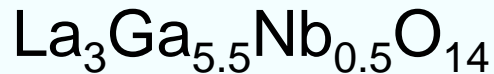

Langannite (LGN)

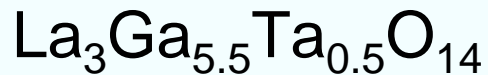

Langatate (LGT)

- Lower acoustic attenuation than quartz (higher Qf than AT- or SC-cut quartz)
- No phase transition (melts at ~1,400 °C vs. phase transition at 573 °C for quartz)
- Higher piezoelectric coupling than quartz
- Thicker than quartz at the same frequency
- Temperature-compensated

# CHAPTER 6

## Atomic Frequency Standards\*

\* There are two important reasons for including this chapter: 1. atomic frequency standards are one of the most important applications of precision quartz oscillators, and 2. those who study or use crystal oscillators ought to be aware of what is available in case they need an oscillator with better long-term stability than what crystal oscillators can provide.

# Precision Frequency Standards

- **Quartz crystal resonator-based** ( $f \sim 5$  MHz,  $Q \sim 10^6$ )
- **Atomic resonator-based**
  - Rubidium cell ( $f_0 = 6.8$  GHz,  $Q \sim 10^7$ )
  - Cesium beam ( $f_0 = 9.2$  GHz,  $Q \sim 10^8$ )
  - Hydrogen maser ( $f_0 = 1.4$  GHz,  $Q \sim 10^9$ )
  - Trapped ions ( $f_0 > 10$  GHz,  $Q > 10^{11}$ )
  - Cesium fountain ( $f_0 = 9.2$  GHz,  $Q \sim 5 \times 10^{11}$ )

# Atomic Frequency Standard Basic Concepts

When an atomic system changes energy from an excited state to a lower energy state, a photon is emitted. The photon frequency  $\nu$  is given by Planck's law

$$\nu = \frac{E_2 - E_1}{h}$$

where  $E_2$  and  $E_1$  are the energies of the upper and lower states, respectively, and  $h$  is Planck's constant. An atomic frequency standard produces an output signal the frequency of which is determined by this intrinsic frequency rather than by the properties of a solid object and how it is fabricated (as it is in quartz oscillators).

The properties of isolated atoms at rest, and in free space, would not change with space and time. Therefore, the frequency of an ideal atomic standard would not change with time or with changes in the environment. Unfortunately, in real atomic frequency standards: 1) the atoms are moving at thermal velocities, 2) the atoms are not isolated but experience collisions and electric and magnetic fields, and 3) some of the components needed for producing and observing the atomic transitions contribute to instabilities.



# Hydrogen-Like Atoms

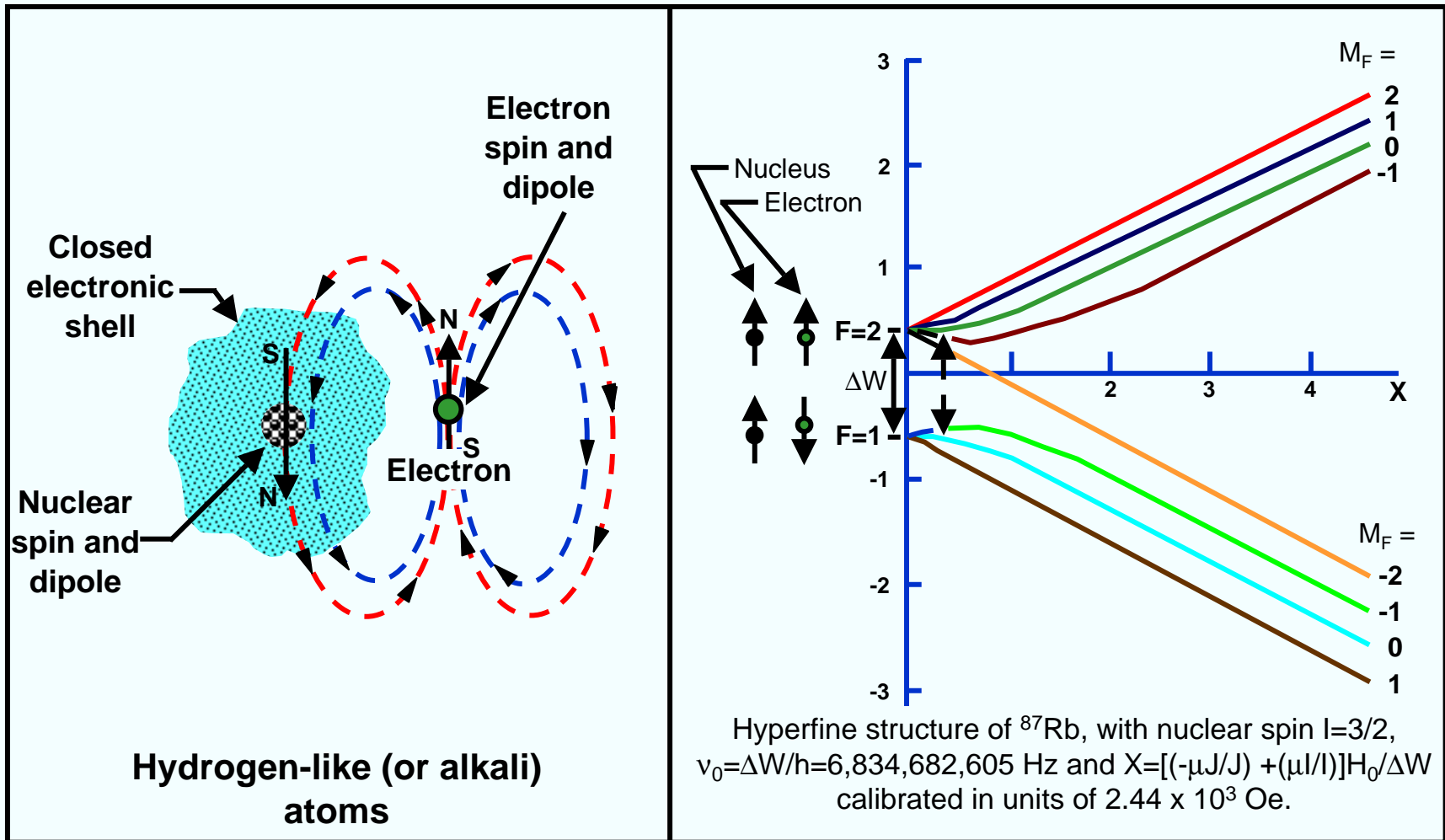

# Atomic Frequency Standard

## Block Diagram

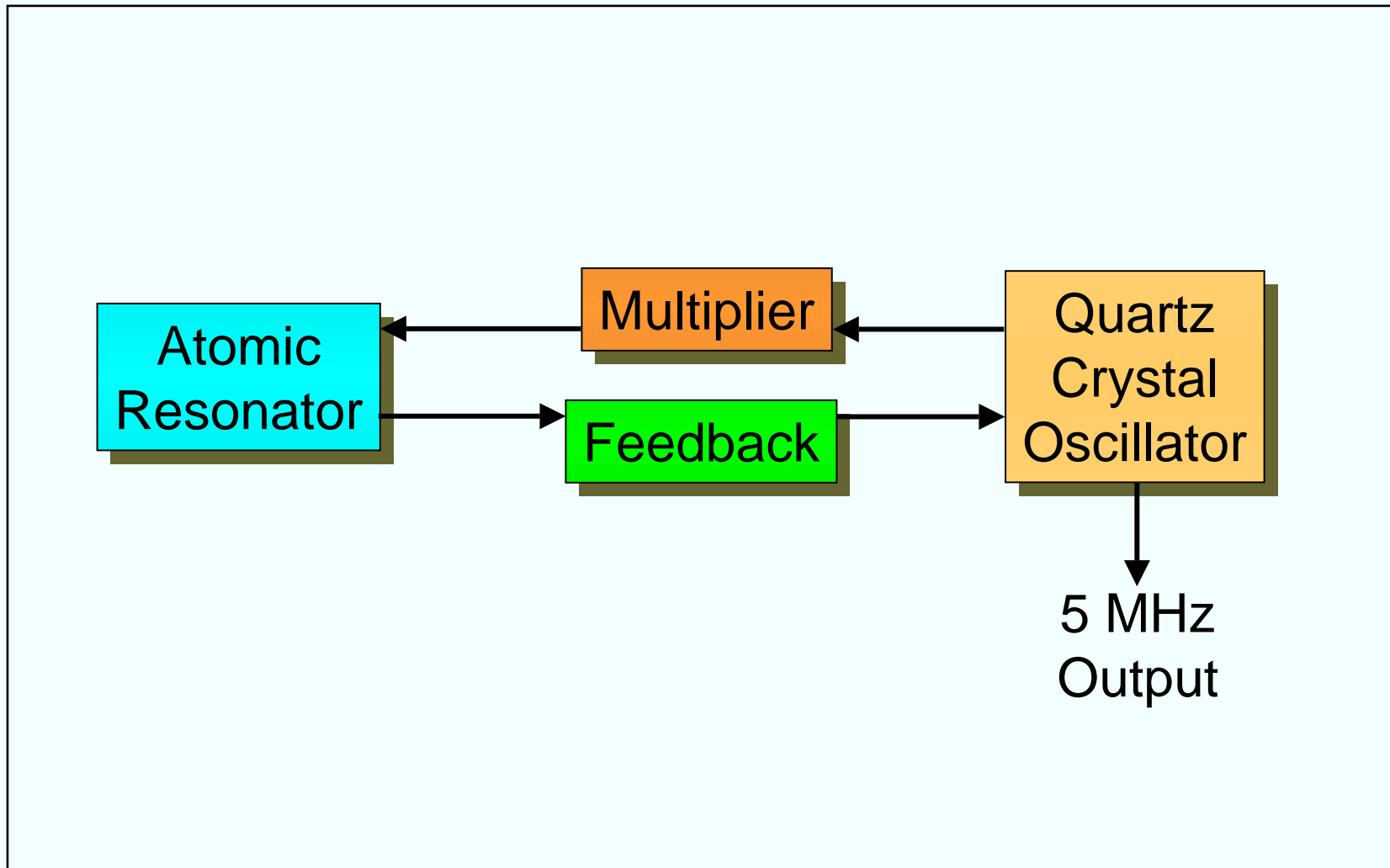

# Generalized Atomic Resonator

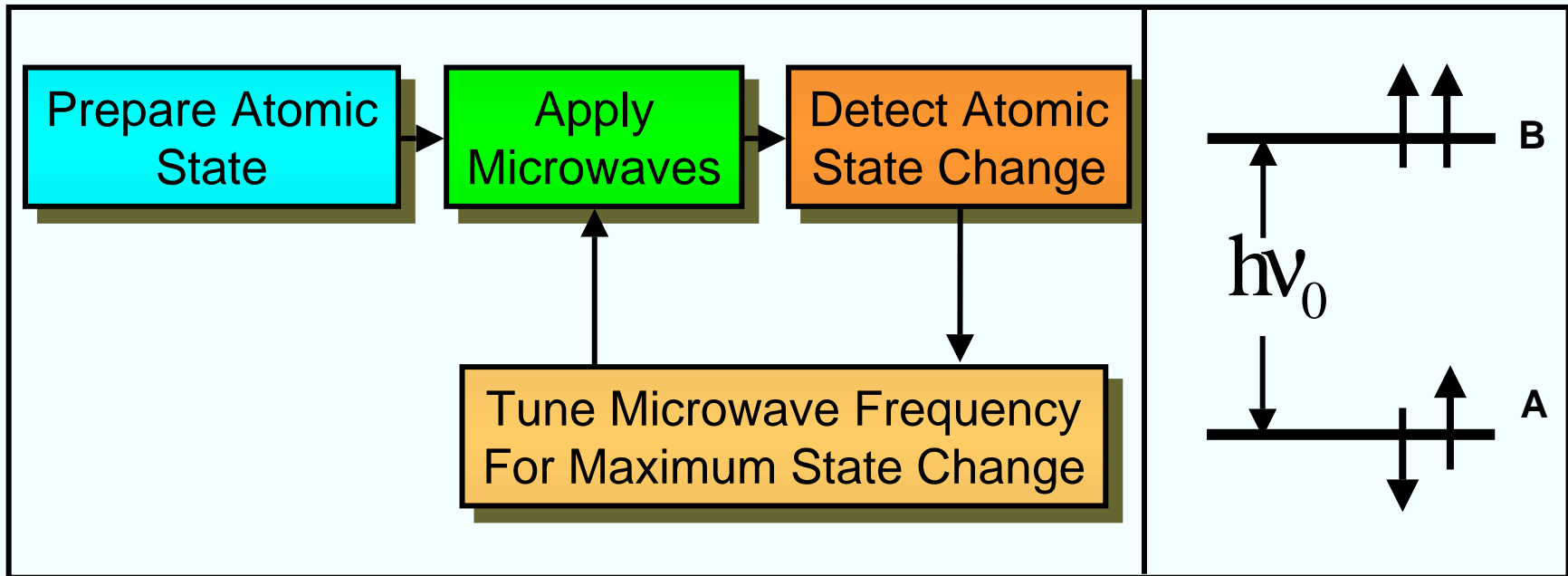

# Atomic Resonator Concepts

- The energy levels used are due to the spin-spin interaction between the atomic nucleus and the outer electron in the ground state ( $^2S_{1/2}$ ) of the atom; i.e., the ground state hyperfine transitions.
- Nearly all atomic standards use Rb or Cs atoms; nuclear spins  $I = 3/2$  and  $7/2$ , respectively.
- Energy levels split into  $2(I \pm 1/2)+1$  sublevels in a magnetic field; the "clock transition" is the transition between the least magnetic-field-sensitive sublevels. A constant magnetic field, the "C-field," is applied to minimize the probability of the more magnetic-field-sensitive transitions.
- Magnetic shielding is used to reduce external magnetic fields (e.g., the earth's) at least 100-fold.
- The Heisenberg uncertainty principle limits the achievable accuracy:  $\Delta E \Delta t \geq h/2\pi$ ,  $E = h\nu$ , therefore,  $\Delta \nu \Delta t \geq 1$ , and, long observation time  $\rightarrow$  small frequency uncertainty.
- Resonance linewidth (i.e.,  $1/Q$ ) is inversely proportional to coherent observation time  $\Delta t$ ;  $\Delta t$  is limited by: 1.) when atom enters and leaves the apparatus, and 2.) when the atom stops oscillating due to collisions with other atoms or with container walls (collisions disturb atom's electronic structure).
- Since atoms move with respect to the microwave source, resonance frequency is shifted due to the Doppler effect ( $\mathbf{k} \cdot \mathbf{v}$ ); velocity distribution results in "Doppler broadening"; the second-order Doppler shift ( $1/2 v^2/c^2$ ) is due to relativistic time dilation.

# Rubidium Cell Frequency Standard

## Energy level diagrams of $^{85}\text{Rb}$ and $^{87}\text{Rb}$

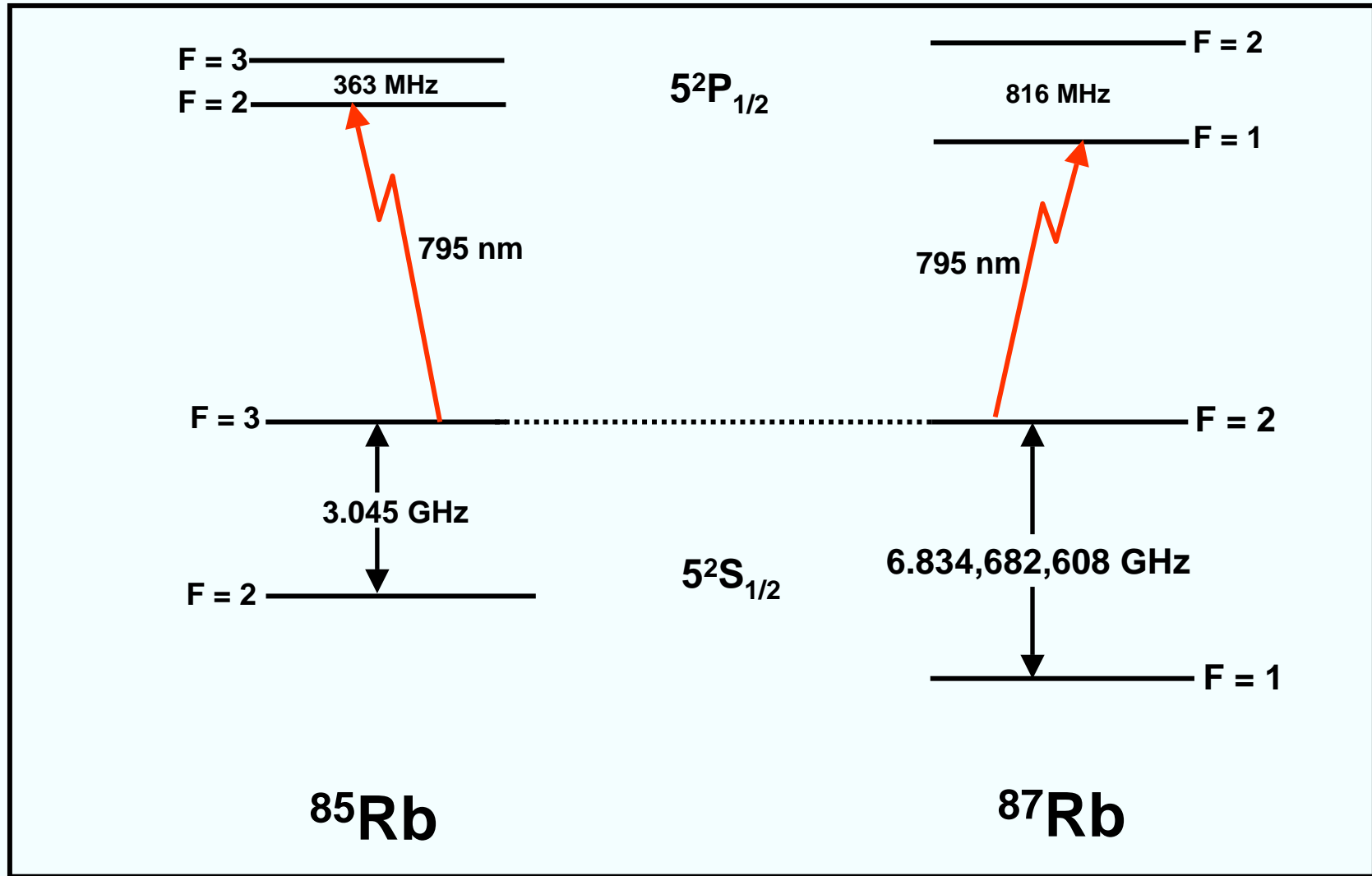

# Rubidium Cell Frequency Standard

## Atomic resonator schematic diagram

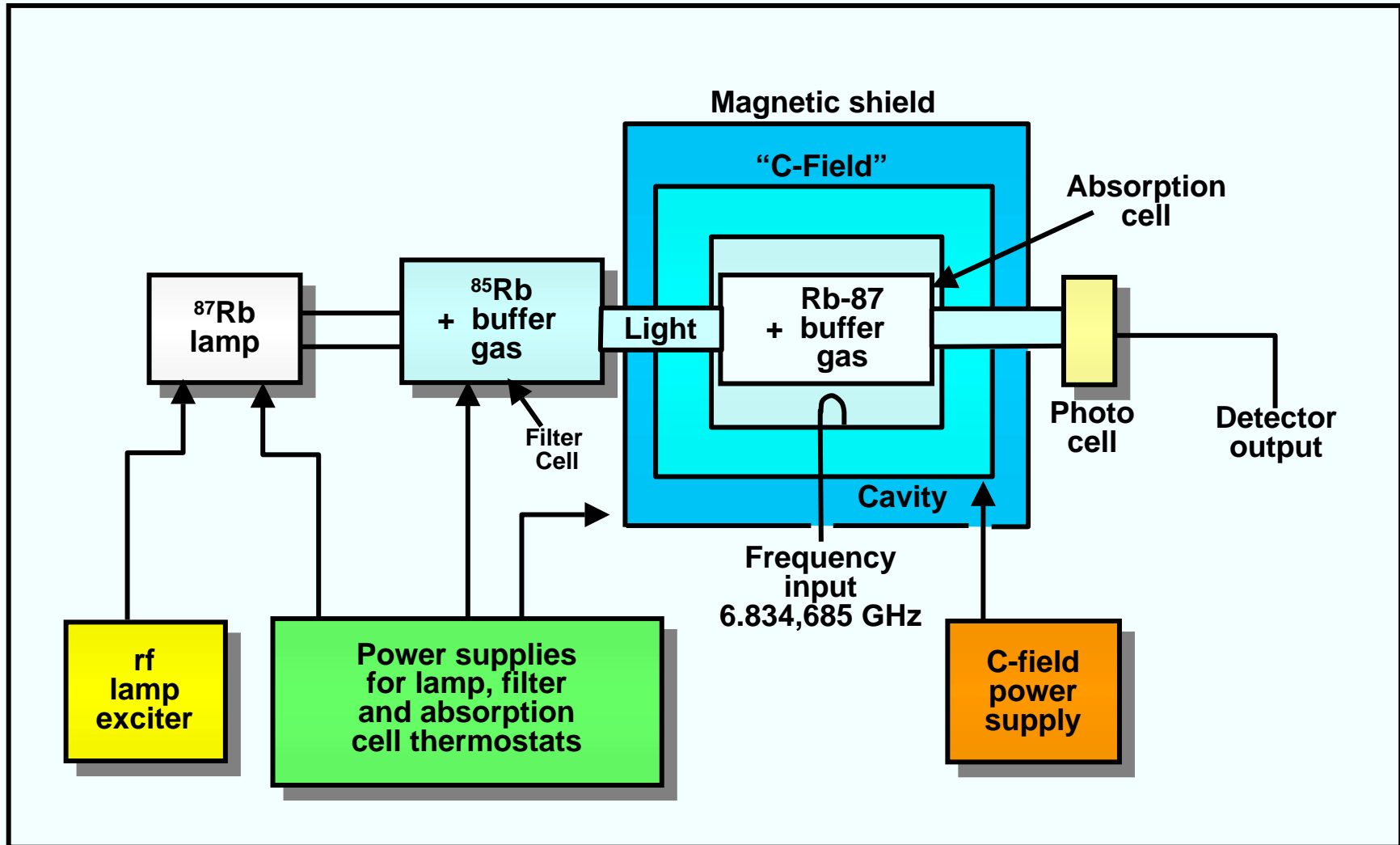

# Cs Hyperfine Energy Levels

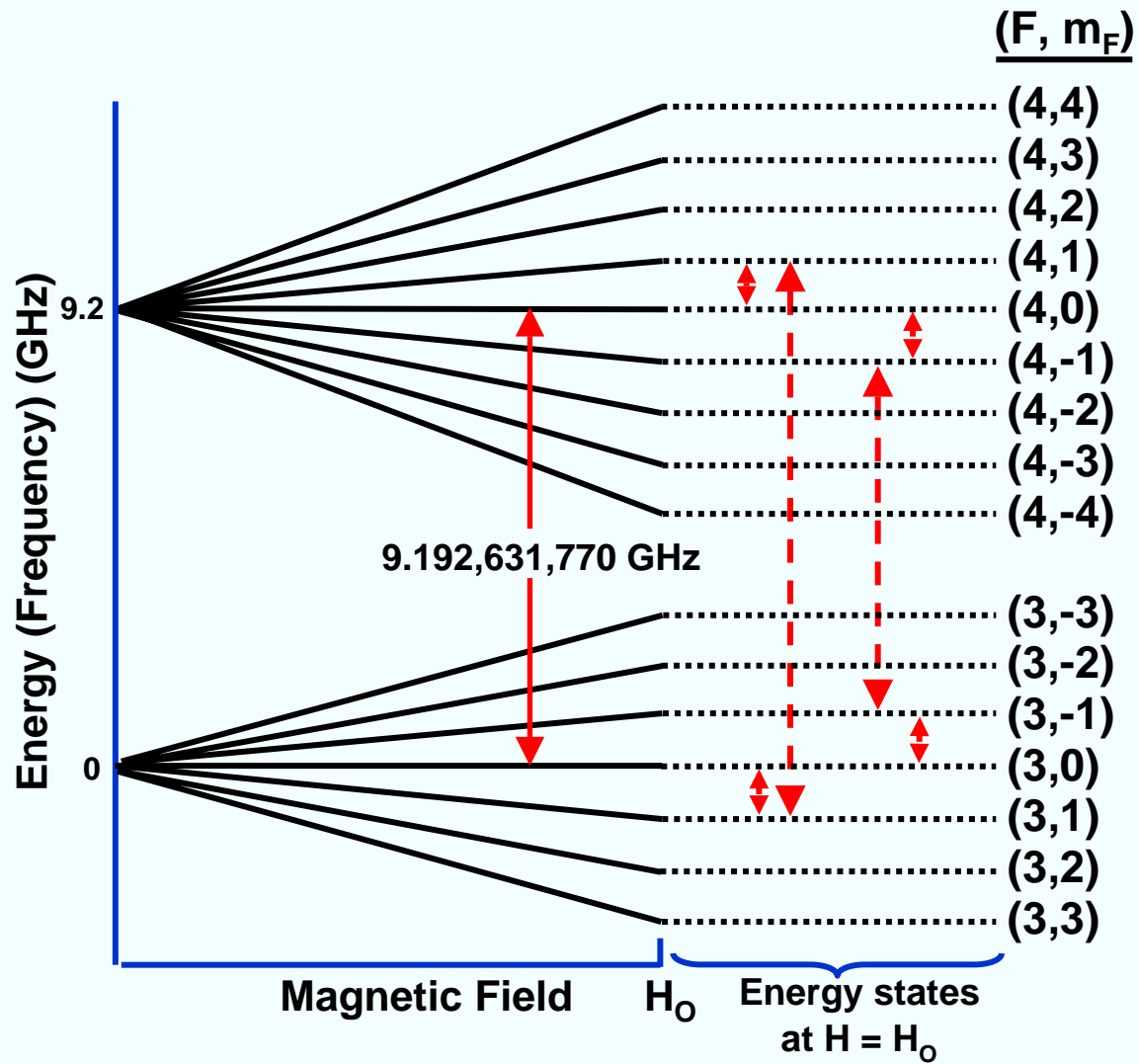

# Cesium-Beam Frequency Standard

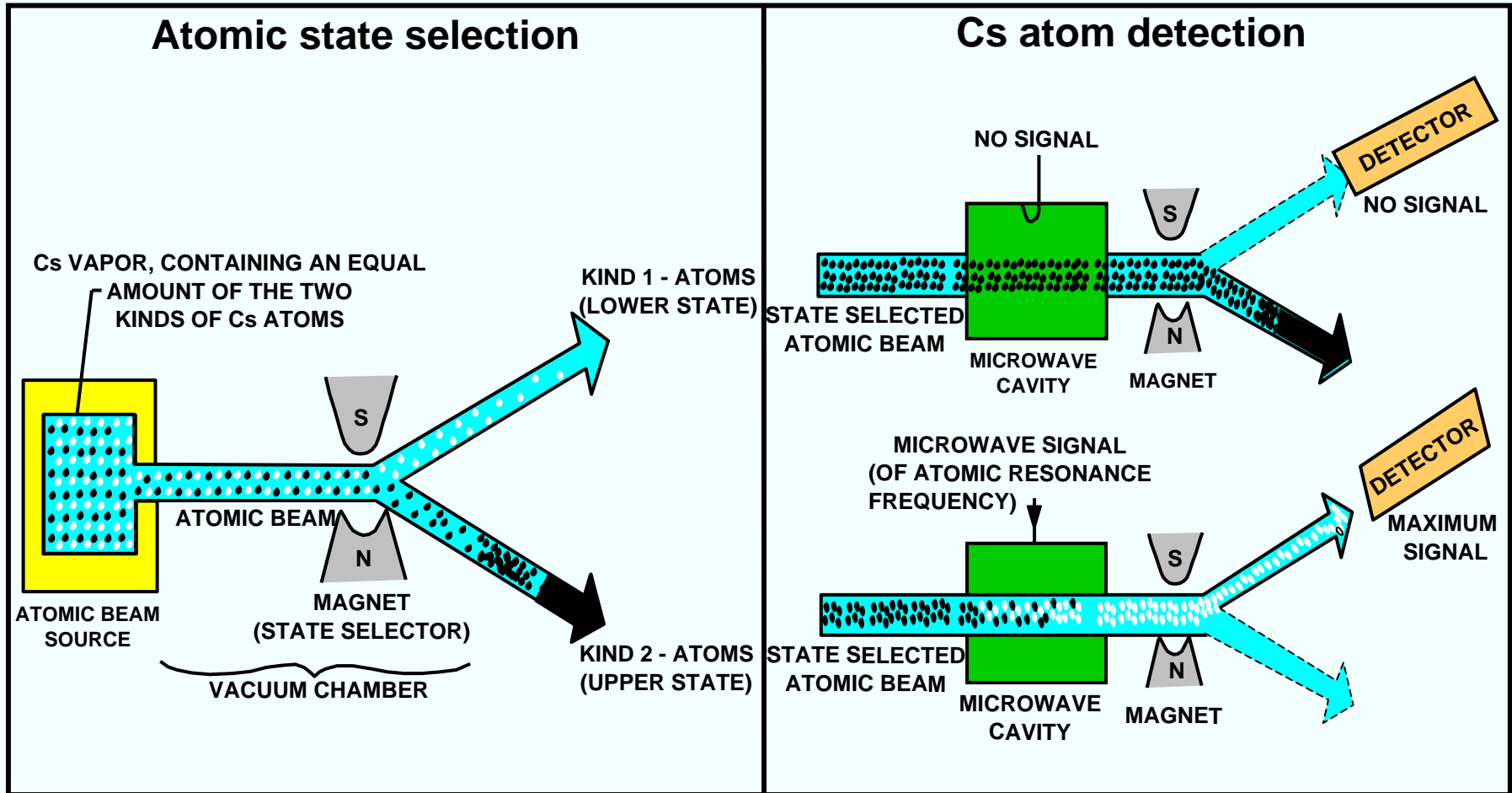



# Cesium-Beam Frequency Standard

Cs atomic resonator schematic diagram

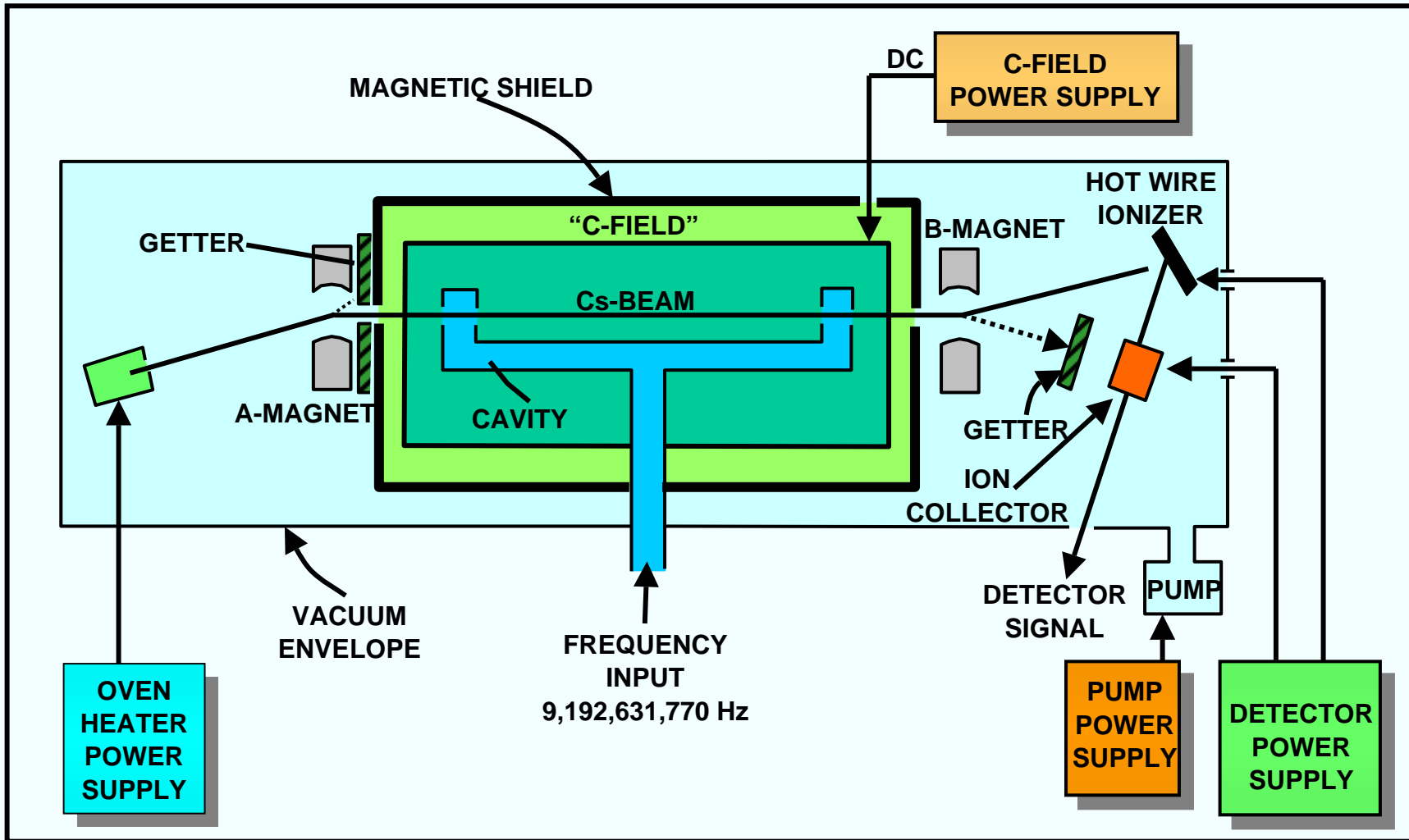

# Atomic Hydrogen Energy Levels

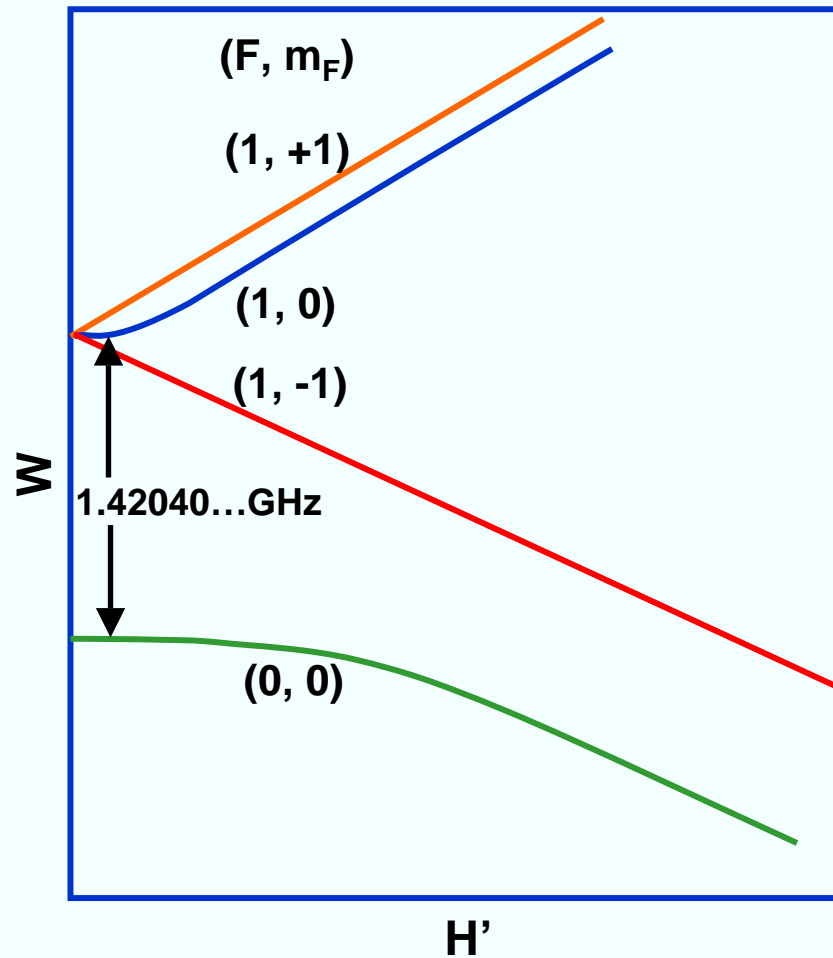

Ground state energy levels of atomic hydrogen as a function of magnetic field  $H'$ .

# Passive H-Maser Schematic Diagram

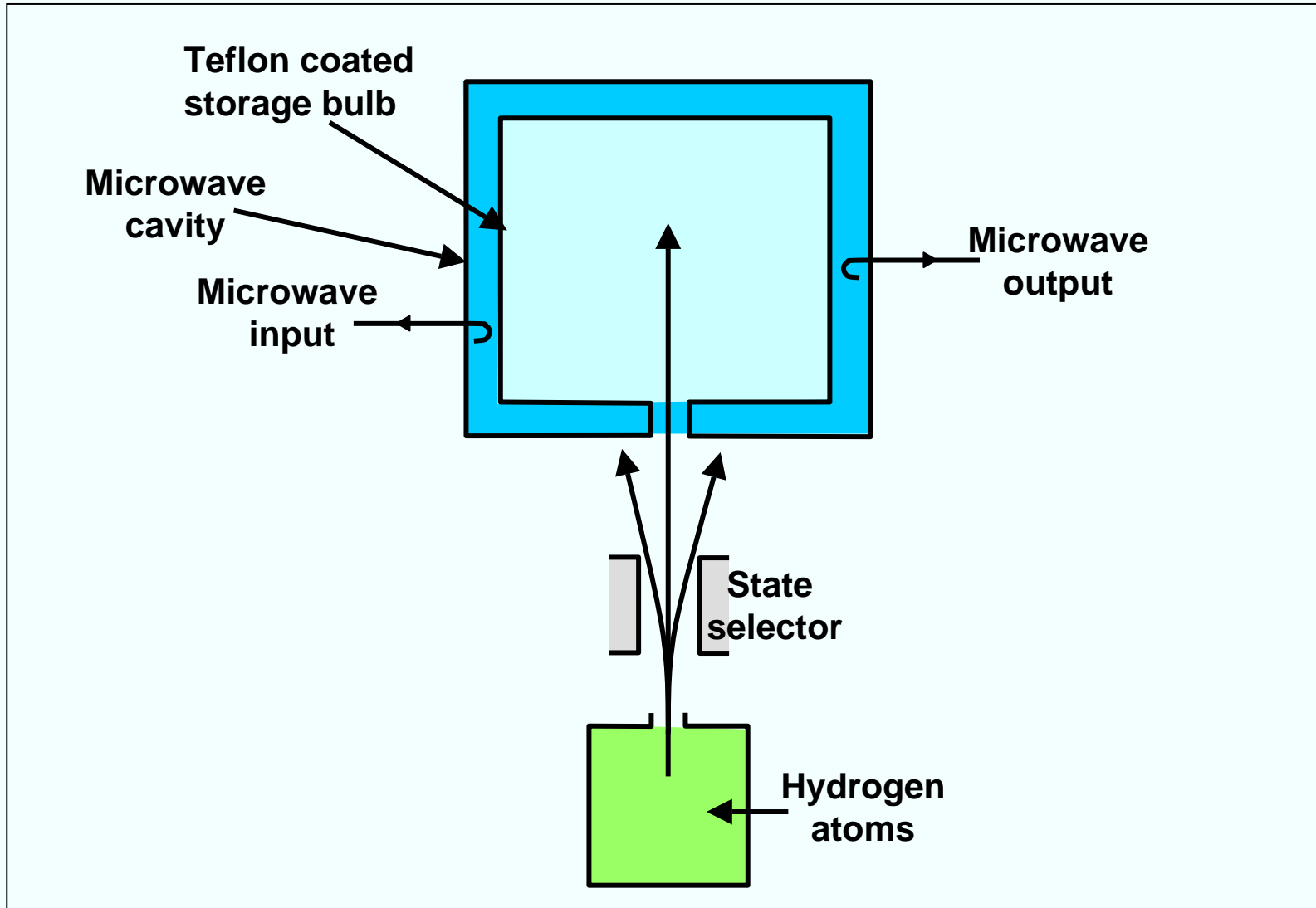

# Atomic Resonator Instabilities

- **Noise** - due to the circuitry, crystal resonator, and atomic resonator. (See next page.)
- **Cavity pulling** - microwave cavity is also a resonator; atoms and cavity behave as two coupled oscillators; effect can be minimized by tuning the cavity to the atomic resonance frequency, and by maximizing the atomic resonance Q to cavity Q ratio.
- **Collisions** - cause frequency shifts and shortening of oscillation duration.
- **Doppler effects** - 1st order is classical, can be minimized by design; 2nd order is relativistic; can be minimized by slowing the atoms via laser cooling - see “Laser Cooling of Atoms” later in this chapter.
- **Magnetic field** - this is the only influence that directly affects the atomic resonance frequency.
- **Microwave spectrum** - asymmetric frequency distribution causes frequency pulling; can be made negligible through proper design.
- **Environmental effects** - magnetic field changes, temperature changes, vibration, shock, radiation, atmospheric pressure changes, and He permeation into Rb bulbs.

# Noise in Atomic Frequency Standards

If the time constant for the atomic-to-crystal servo-loop is  $t_0$ , then at  $\tau < t_0$ , the crystal oscillator determines  $\sigma_y(\tau)$ , i.e.,  $\sigma_y(\tau) \sim \tau^{-1}$ . From  $\tau > t_0$  to the  $\tau$  where the "flicker floor" begins, variations in the atomic beam intensity (shot-noise) determine  $\sigma_y(\tau)$ , and  $\sigma_y(\tau) \sim (i\tau)^{-1/2}$ , where  $i$  = number of signal events per second. Shot noise within the feedback loop shows up as white frequency noise (random walk of phase). Shot noise is generally present in any electronic device (vacuum tube, transistor, photodetector, etc.) where discrete particles (electrons, atoms) move across a potential barrier in a random way.

In commercial standards,  $t_0$  ranges from 0.01 s for a small Rb standard to 60 s for a high-performance Cs standard. In the regions where  $\sigma_y(\tau)$  varies as  $\tau^{-1}$  and  $\tau^{-1/2}$ ,  $\sigma_y(\tau) \propto (QS_R)^{-1}$ , where  $S_R$  is the signal-to-noise ratio, i.e., the higher the  $Q$  and the signal-to-noise ratio, the better the short term stability (and the phase noise far from the carrier, in the frequency domain).

# Short-Term Stability of a Cs Standard

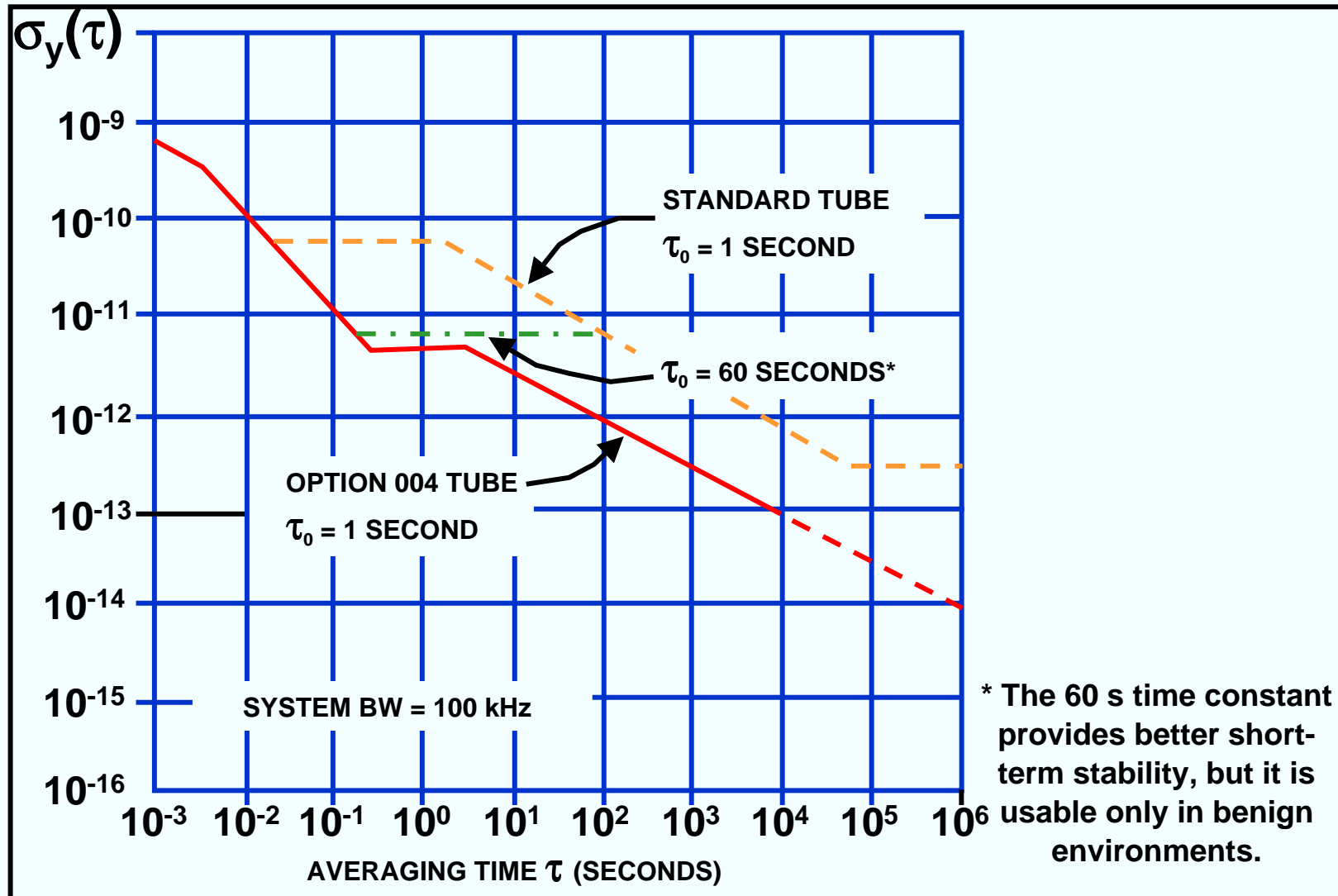

# Short-Term Stability of a Rb Standard

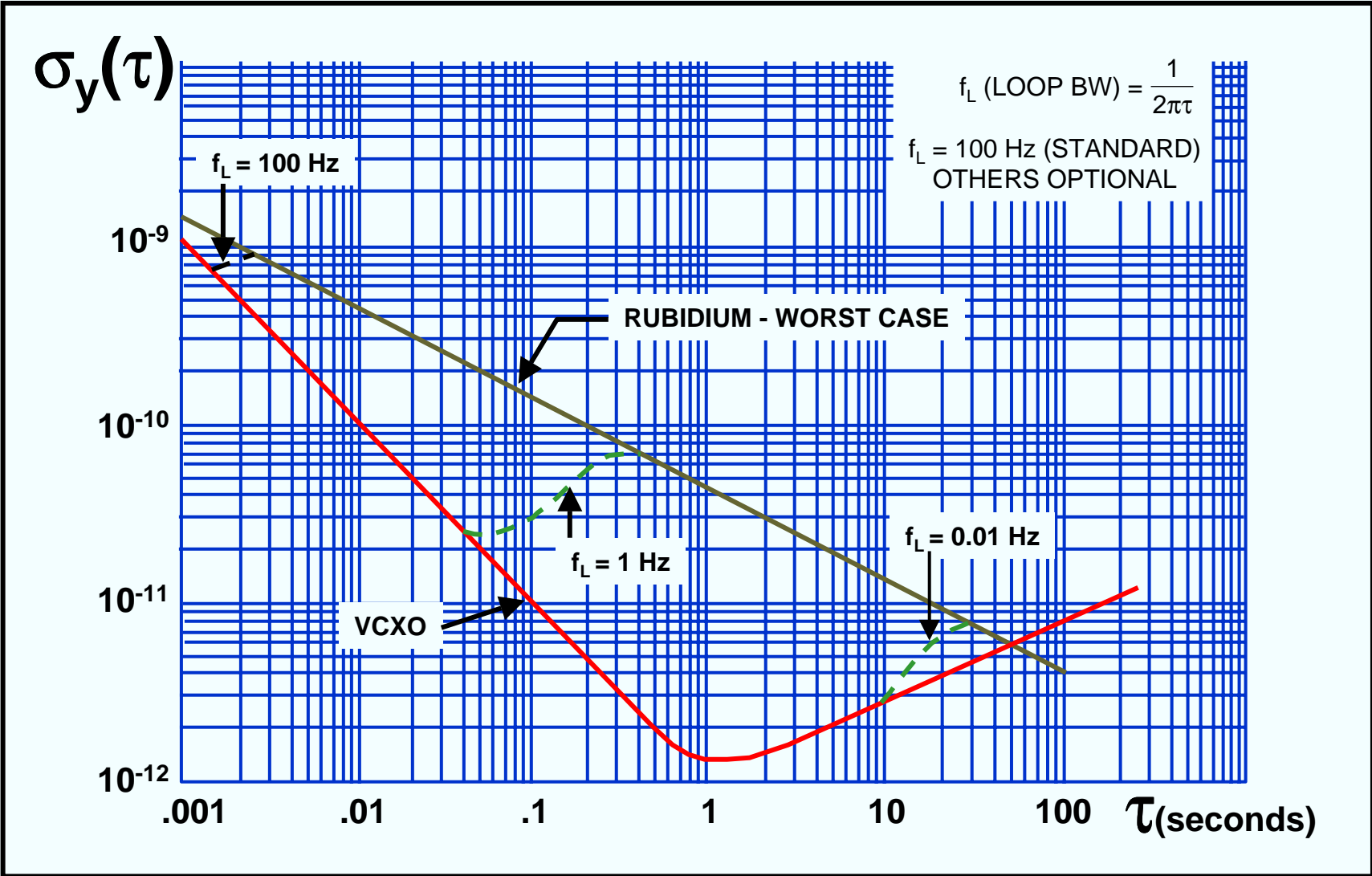

# Acceleration Sensitivity of Atomic Standards

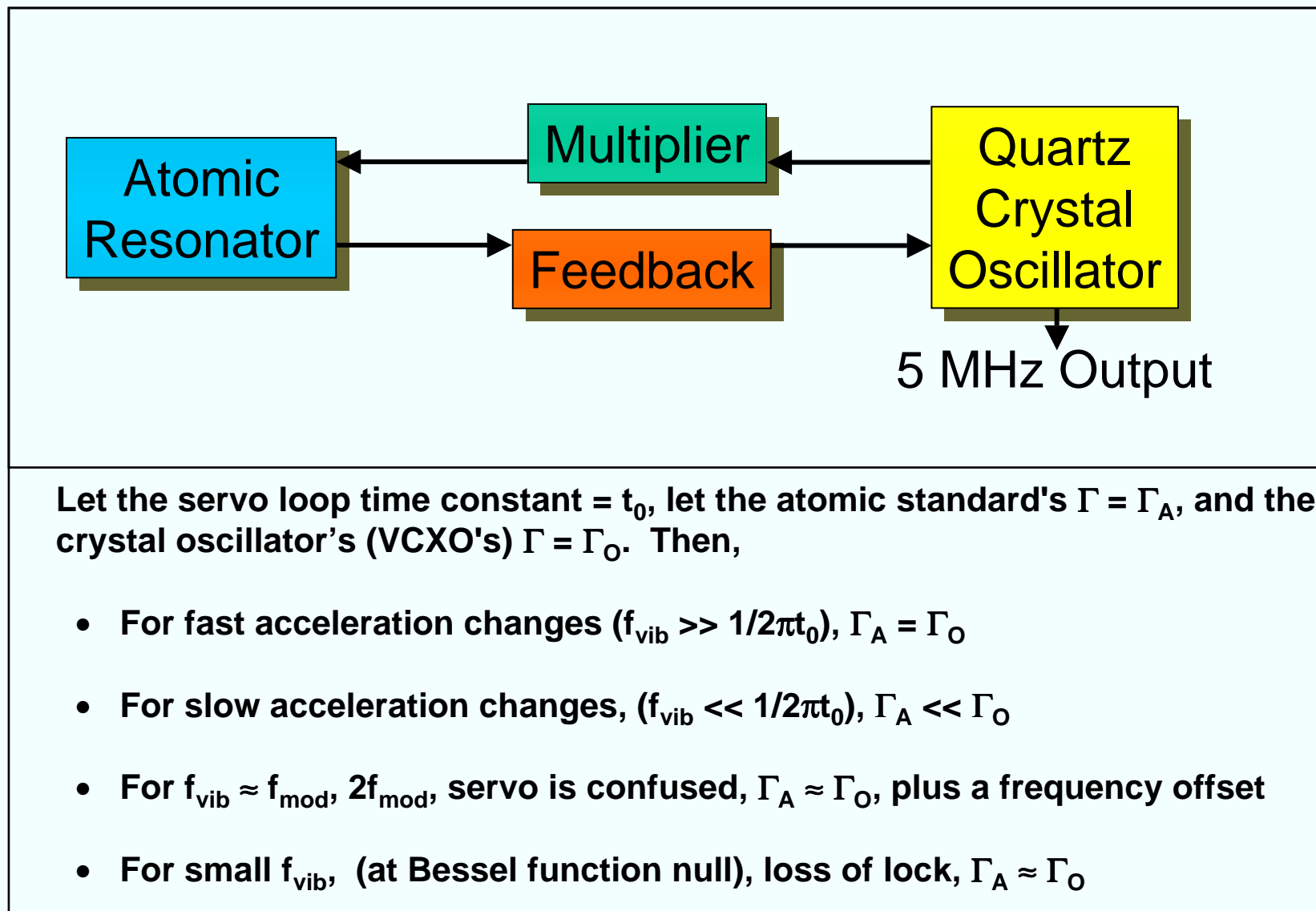



# Atomic Standard Acceleration Effects

**In Rb cell standards**, high acceleration can cause  $\Delta f$  due to light shift, power shift, and servo effects:

- Location of molten Rb in the Rb lamp can shift
- Mechanical changes can deflect light beam
- Mechanical changes can cause rf power changes

**In Cs beam standards**, high acceleration can cause  $\Delta f$  due to changes in the atomic trajectory with respect to the tube & microwave cavity structures:

- Vibration modulates the amplitude of the detected signal.  
Worst when  $f_{\text{vib}} = f_{\text{mod}}$ .
- Beam to cavity position change causes cavity phase shift effects
- Velocity distribution of Cs atoms can change
- Rocking effect can cause  $\Delta f$  even when  $f_{\text{vib}} < f_{\text{mod}}$

**In H-masers**, cavity deformation causes  $\Delta f$  due to cavity pulling effect

# Magnetic Field Sensitivities of Atomic Clocks

Clock transition frequency  $\nu = \nu_o + C_H H_o^2$ , where  $C_H$  is the quadratic Zeeman effect coefficient (which varies as  $1/\nu_o$ ).

Atom	Transition Frequency	C-field* (milligauss)**	Shielding Factor*	Sensitivity per gauss**
Rb	$\nu=6.8 \text{ GHz} + (574 \text{ Hz/G}^2) B_o^2$	250	5k	$10^{-11}$
Cs	$\nu=9.2 \text{ GHz} + (427 \text{ Hz/G}^2) B_o^2$	60	50k	$10^{-13}$
H	$\nu=1.4 \text{ GHz} + (2750 \text{ Hz/G}^2) B_o^2$	0.5	50k	$10^{-13}$

\* Typical values

\*\* 1 gauss =  $10^{-4}$  Tesla; Tesla is the SI unit of magnetic flux density.

# Crystal's Influences on Atomic Standard

- **Short term stability** - for averaging times less than the atomic-to-crystal servo loop time constant,  $\tau_L$ , the crystal oscillator determines  $\sigma_y(\tau)$ .
- **Loss of lock** - caused by large phase excursions in  $t < \tau_L$  (due to shock, attitude change, vibration, thermal transient, radiation pulse). At a Rb standard's 6.8 GHz, for a  $\Delta f = 1 \times 10^{-9}$  in 1s, as in a 2g tipover in 1s,  $\Delta\phi \sim 7\pi$ . Control voltage sweeping during reacquisition attempt can cause the phase and frequency to change wildly.
- **Maintenance or end of life** - when crystal oscillator frequency offset due to aging approaches EFC range (typically  $\sim 1$  to  $2 \times 10^{-7}$ ).
- **Long term stability** - noise at second harmonic of modulation  $f$  causes time varying  $\Delta f$ 's; this effect is significant only in the highest stability (e.g., H and Hg) standards.

# Optically Pumped Cs Standard

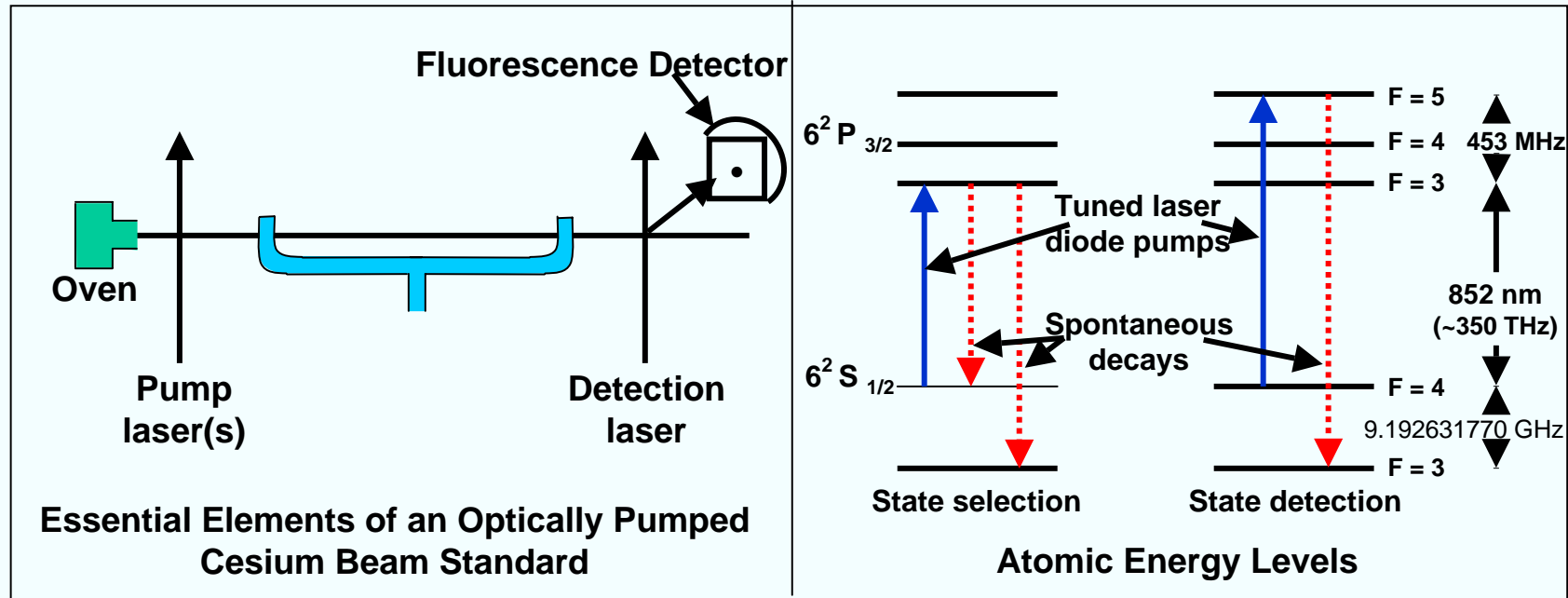

The proper atomic energy levels are populated by optical pumping with a laser diode. This method provides superior utilization of Cs atoms, and provides the potential advantages of: higher S/N, longer life, lower weight, and the possibility of trading off size for accuracy. A miniature Cs standard of  $1 \times 10^{-11}$  accuracy, and  $\ll 1$  liter volume, i.e., about 100x higher accuracy than a Rb standard, in a smaller volume (but not necessarily the same shape factor) seems possible.

# Laser Cooling of Atoms

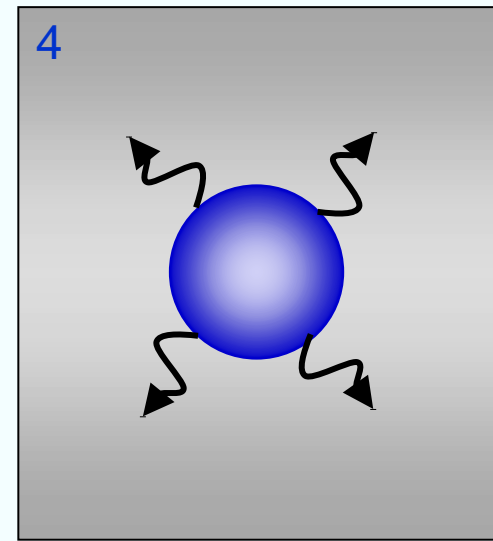
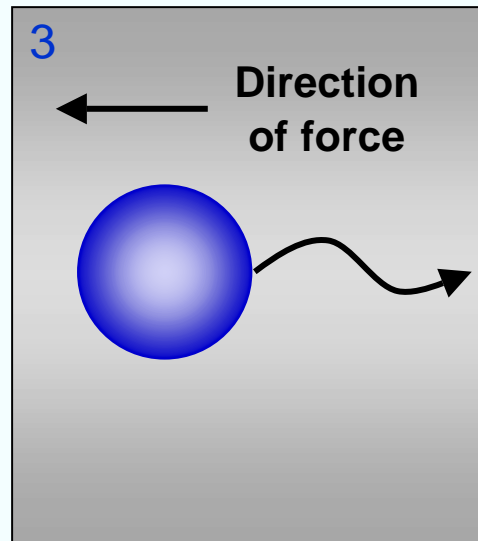
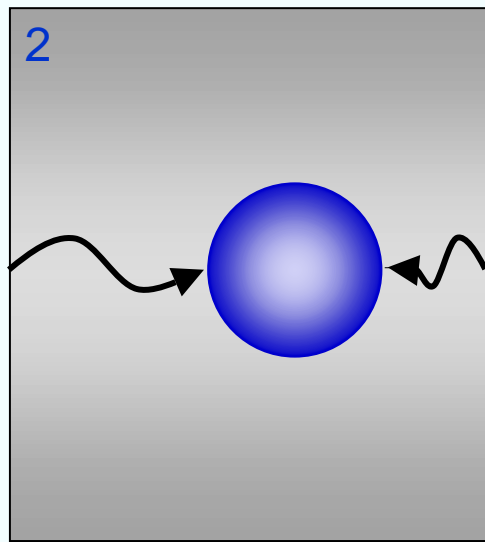
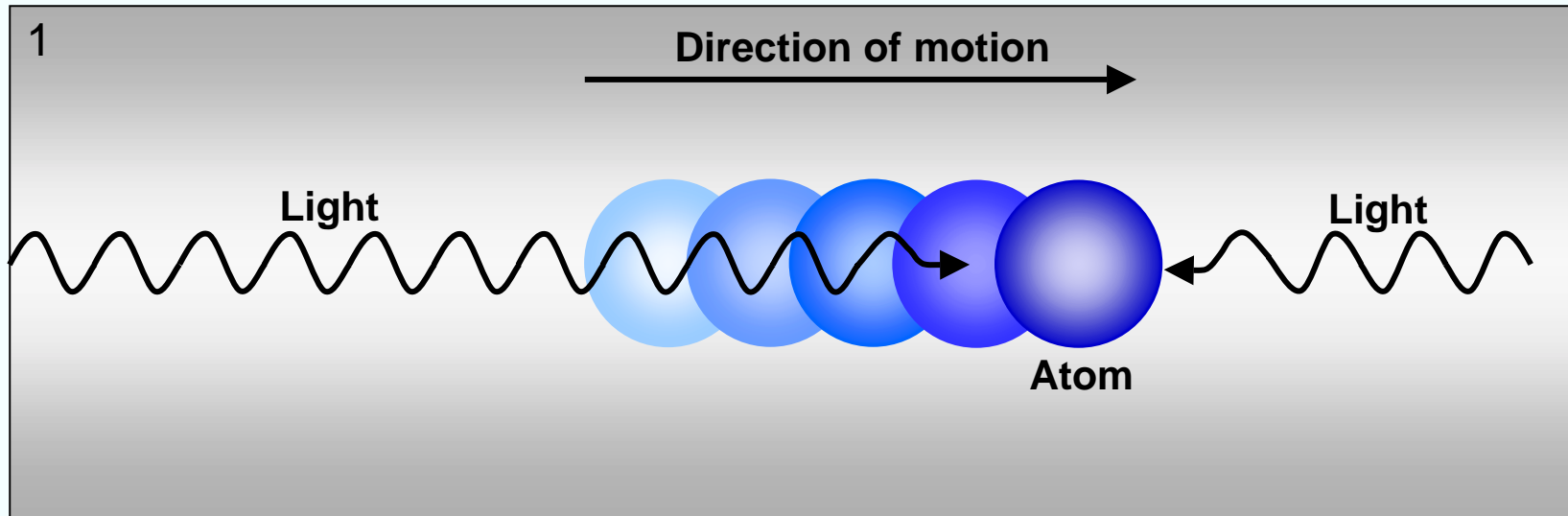

# Rubidium - Crystal Oscillator (RbXO)

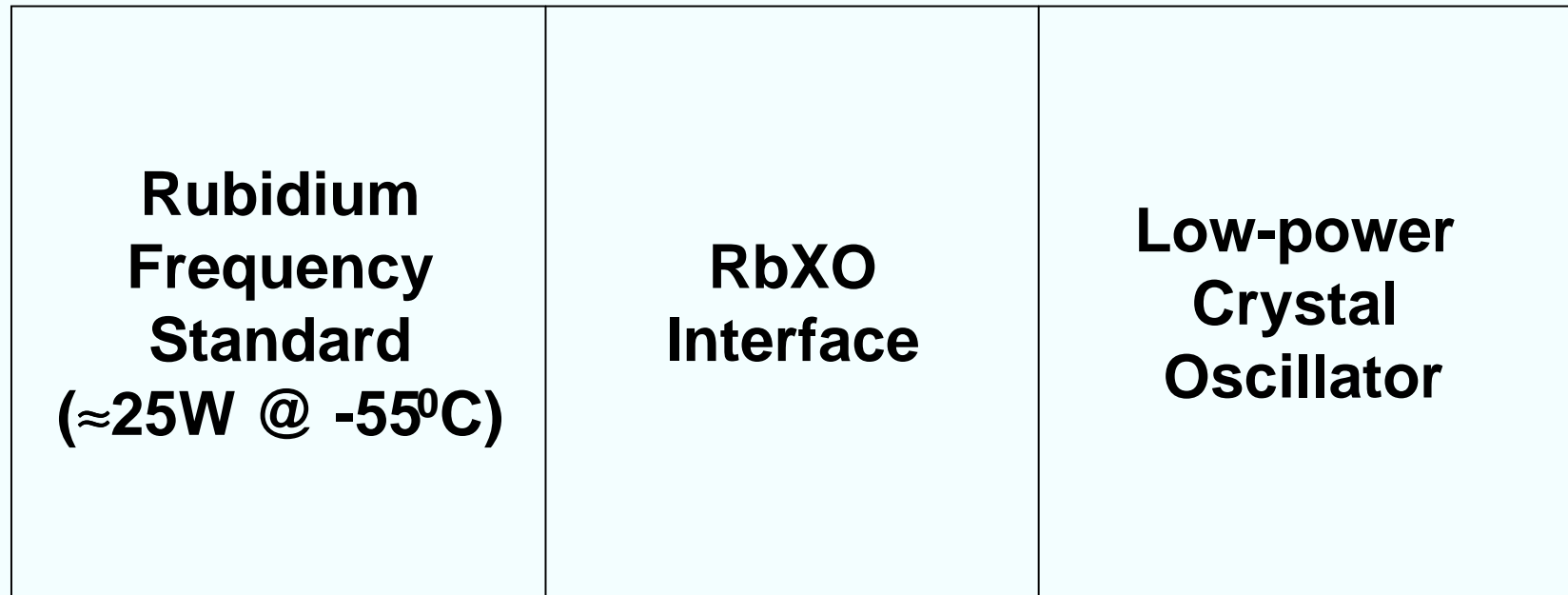

# RbXO Principle of Operation

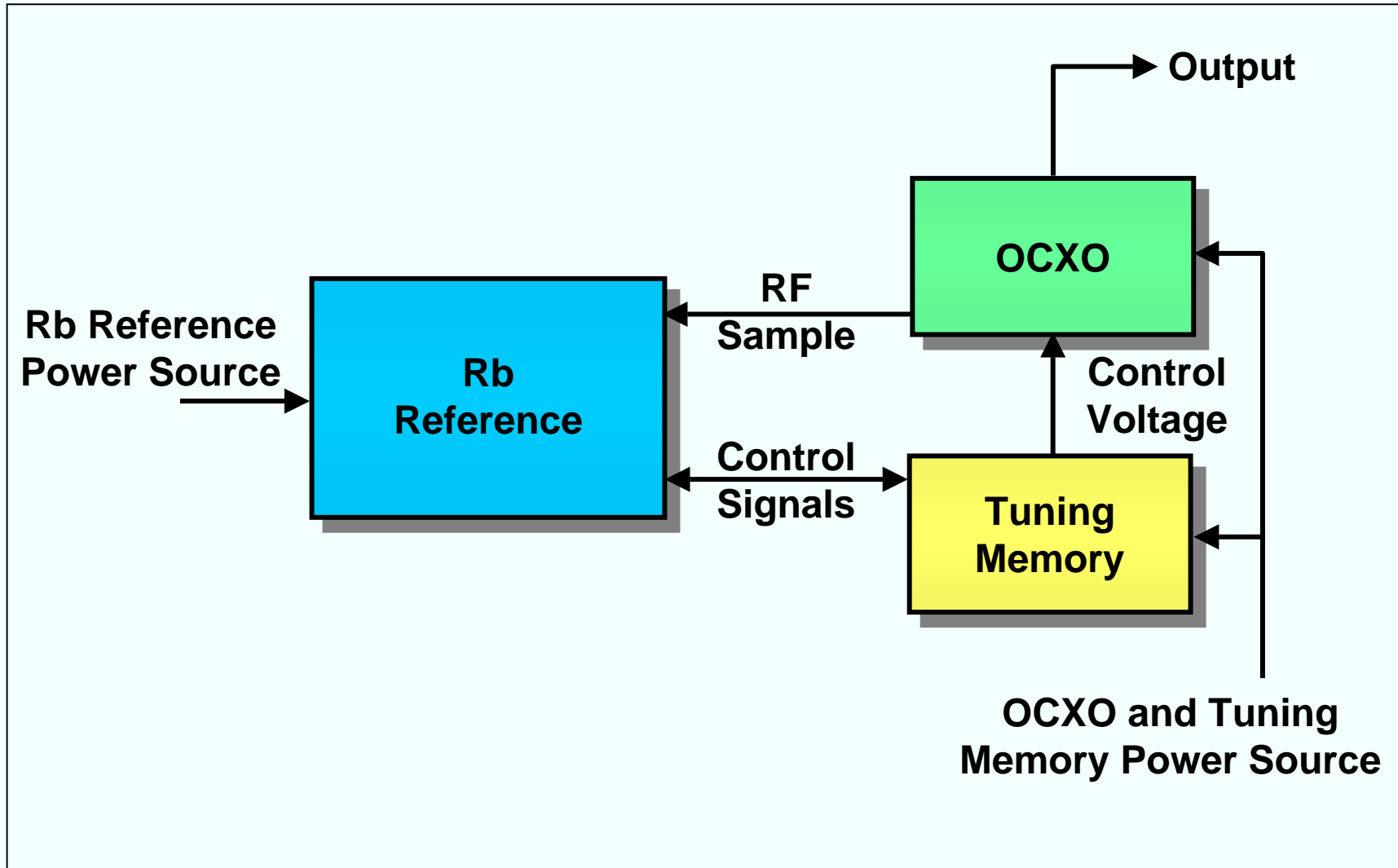

# Rubidium Crystal Oscillator

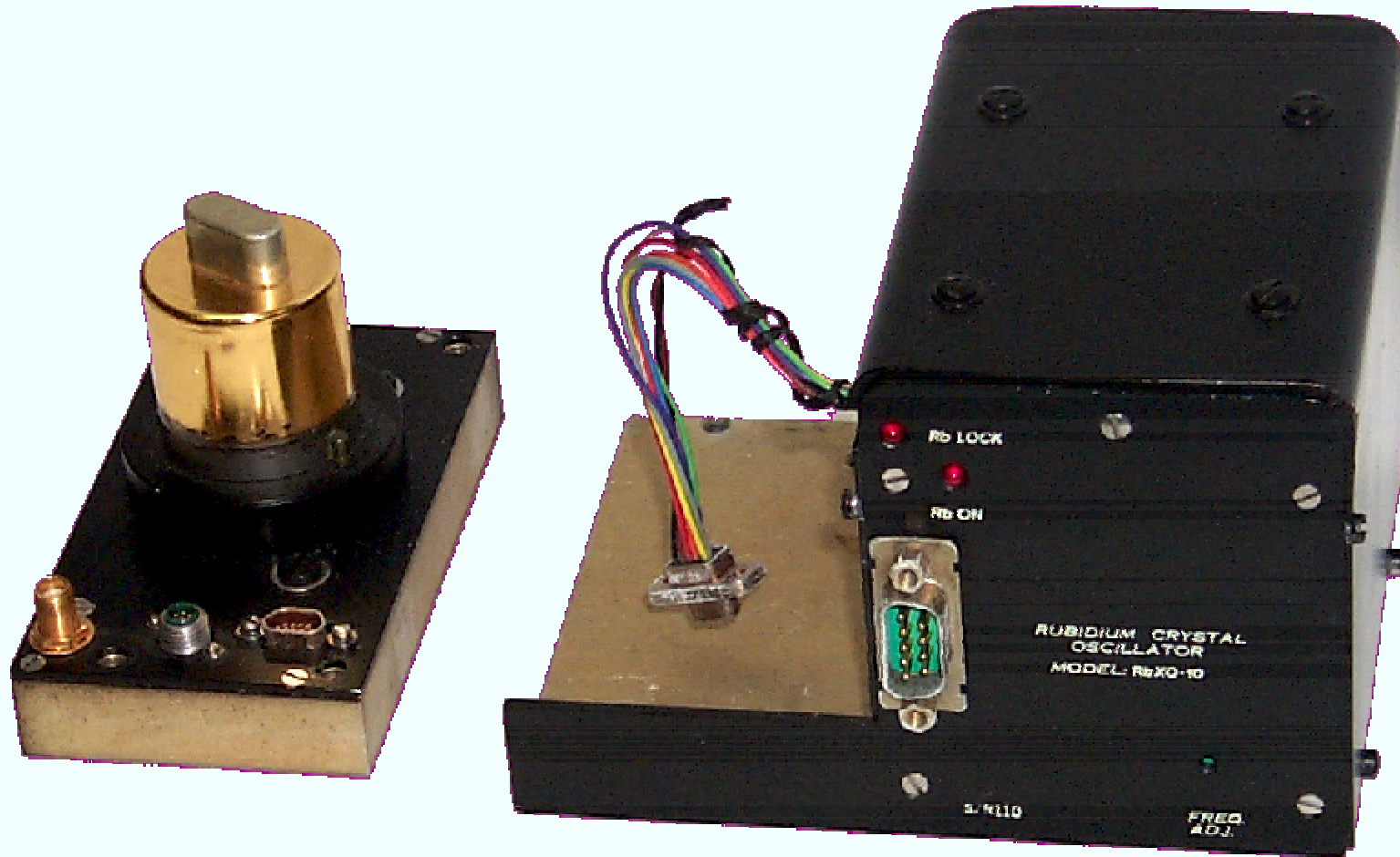



**CHAPTER 7**  
**Oscillator Comparisons and**  
**Specifications**

# Oscillator Comparison

	Quartz Oscillators			Atomic Oscillators		
	TCXO	MCXO	OCXO	Rubidium	RbXO	Cesium
Accuracy * (per year)	$2 \times 10^{-6}$	$5 \times 10^{-8}$	$1 \times 10^{-8}$	$5 \times 10^{-10}$	$7 \times 10^{-10}$	$2 \times 10^{-11}$
Aging/Year	$5 \times 10^{-7}$	$2 \times 10^{-8}$	$5 \times 10^{-9}$	$2 \times 10^{-10}$	$2 \times 10^{-10}$	0
Temp. Stab. (range, °C)	$5 \times 10^{-7}$ (-55 to +85)	$3 \times 10^{-8}$ (-55 to +85)	$1 \times 10^{-9}$ (-55 to +85)	$3 \times 10^{-10}$ (-55 to +68)	$5 \times 10^{-10}$ (-55 to +85)	$2 \times 10^{-11}$ (-28 to +65)
Stability, $\sigma_y(\tau)$ ( $\tau = 1\text{s}$ )	$1 \times 10^{-9}$	$3 \times 10^{-10}$	$1 \times 10^{-12}$	$3 \times 10^{-12}$	$5 \times 10^{-12}$	$5 \times 10^{-11}$
Size (cm <sup>3</sup> )	10	30	20-200	200-800	1,000	6,000
Warmup Time (min)	0.03 (to $1 \times 10^{-6}$ )	0.03 (to $2 \times 10^{-8}$ )	4 (to $1 \times 10^{-8}$ )	3 (to $5 \times 10^{-10}$ )	3 (to $5 \times 10^{-10}$ )	20 (to $2 \times 10^{-11}$ )
Power (W) (at lowest temp.)	0.04	0.04	0.6	20	0.65	30
Price (~\$)	10 - 100	<1,000	200-2,000	2,000-8,000	<10,000	50,000

\* Including environmental effects (note that the temperature ranges for Rb and Cs are narrower than for quartz).

# Clock Accuracy vs. Power Requirement\*

(Goal of R&D is to move technologies toward the upper left)

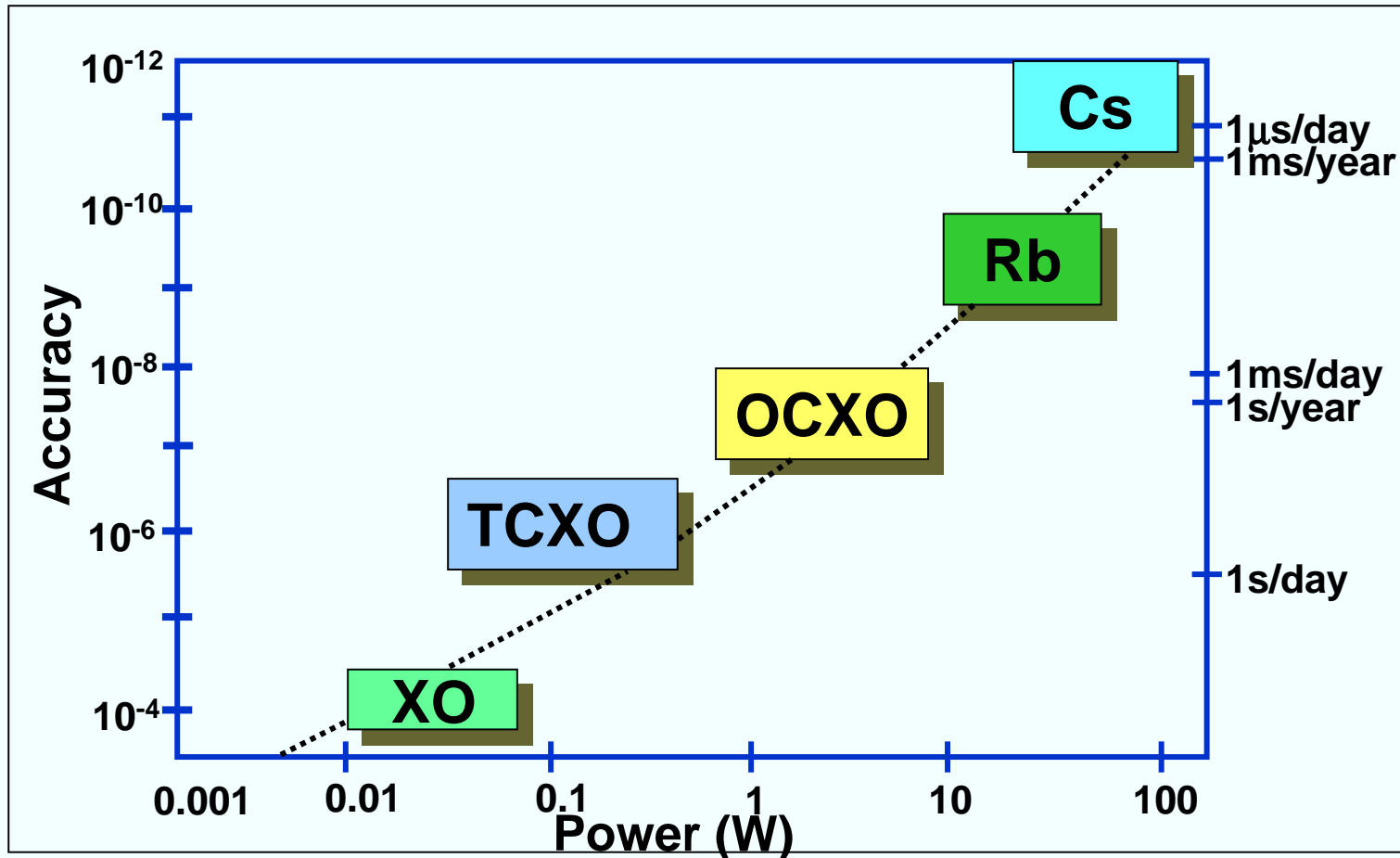

\* Accuracy vs, size, and accuracy vs. cost have similar relationships

# Clock Accuracy vs. Power Requirement\*

(Goal of R&D is to move technologies toward the upper left)

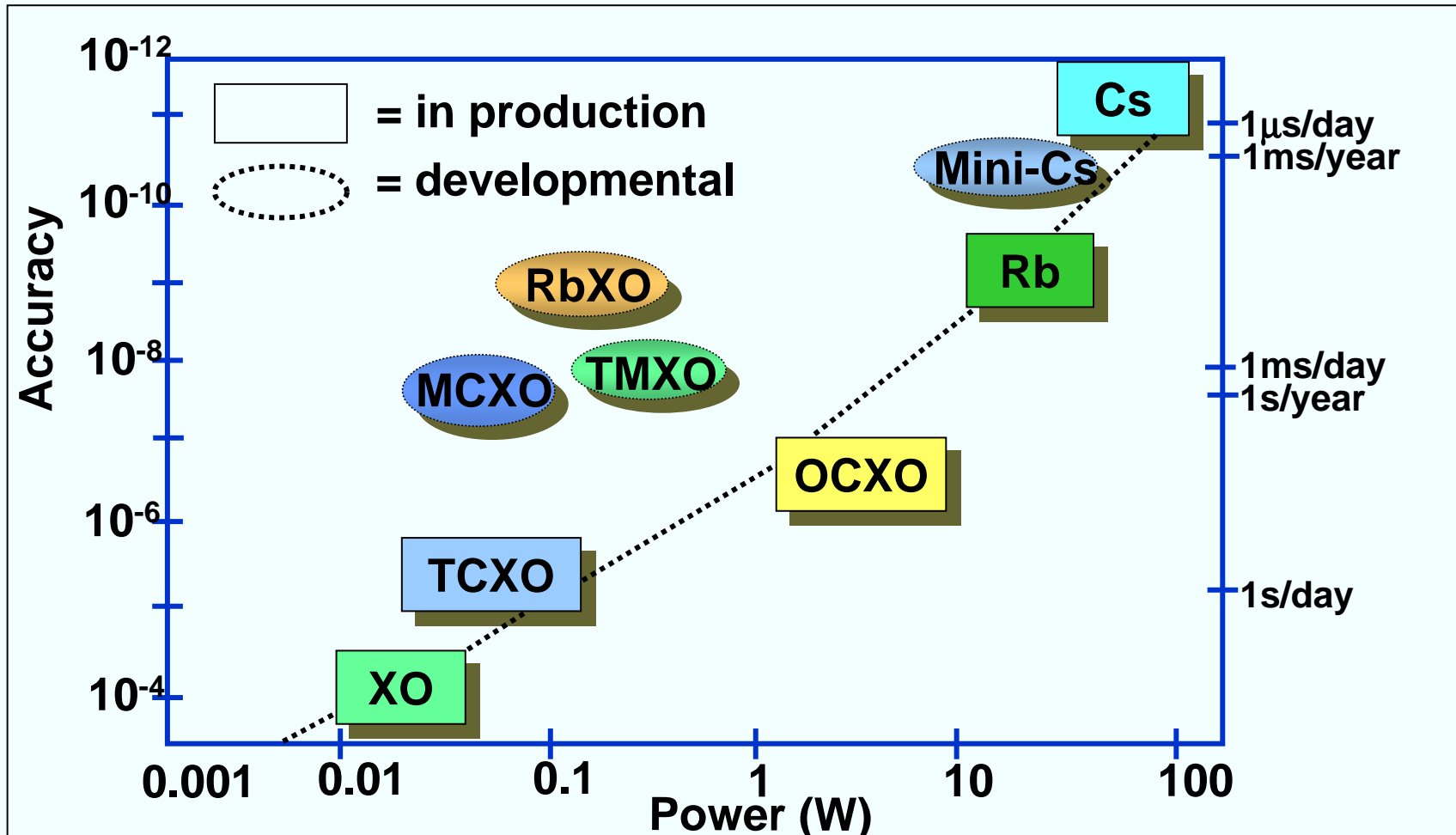

\* Accuracy vs, size, and accuracy vs. cost have similar relationships

# Short Term Stability Ranges of Various Frequency Standards

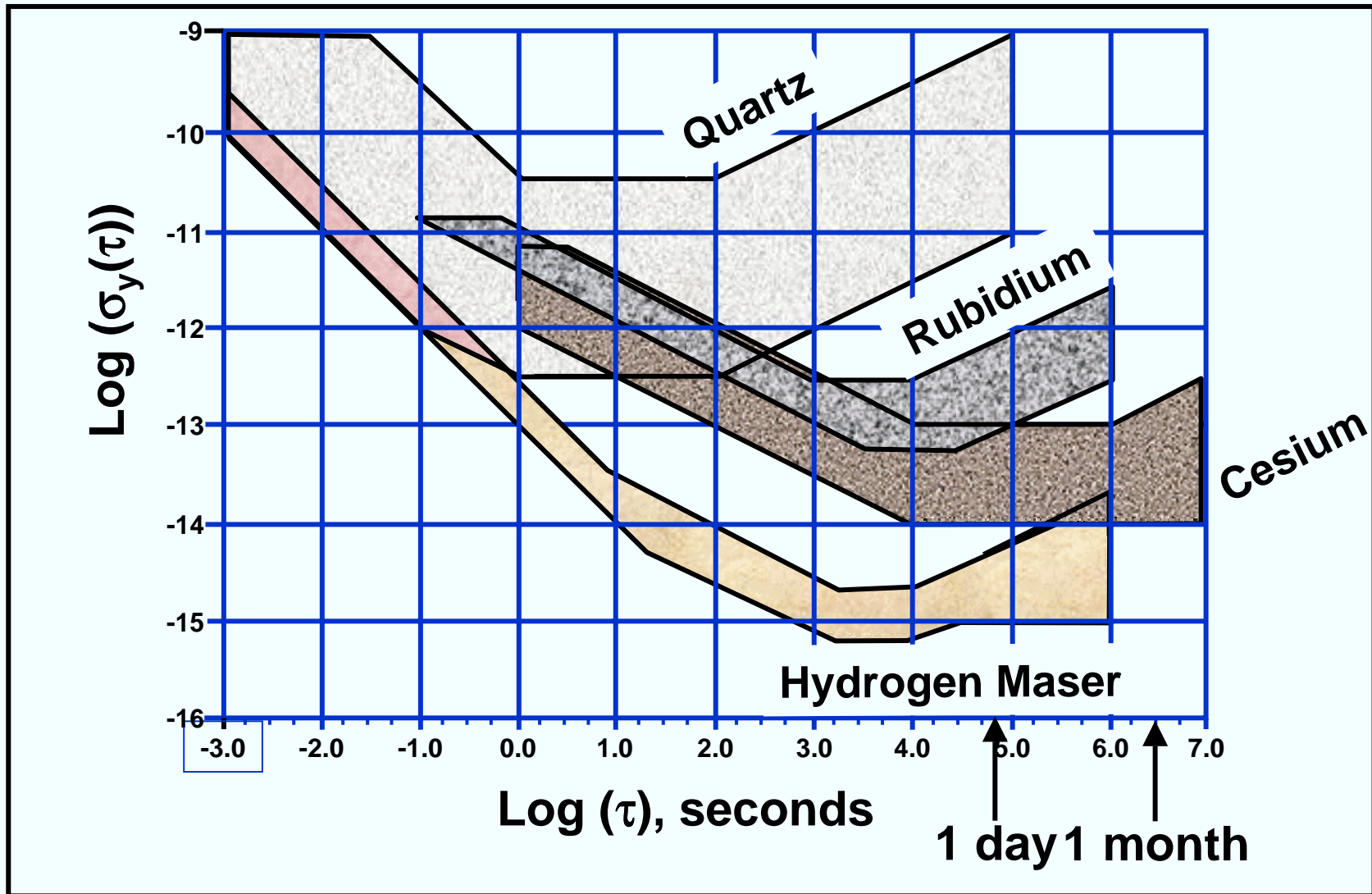

# Phase Instabilities of Various Frequency Standards

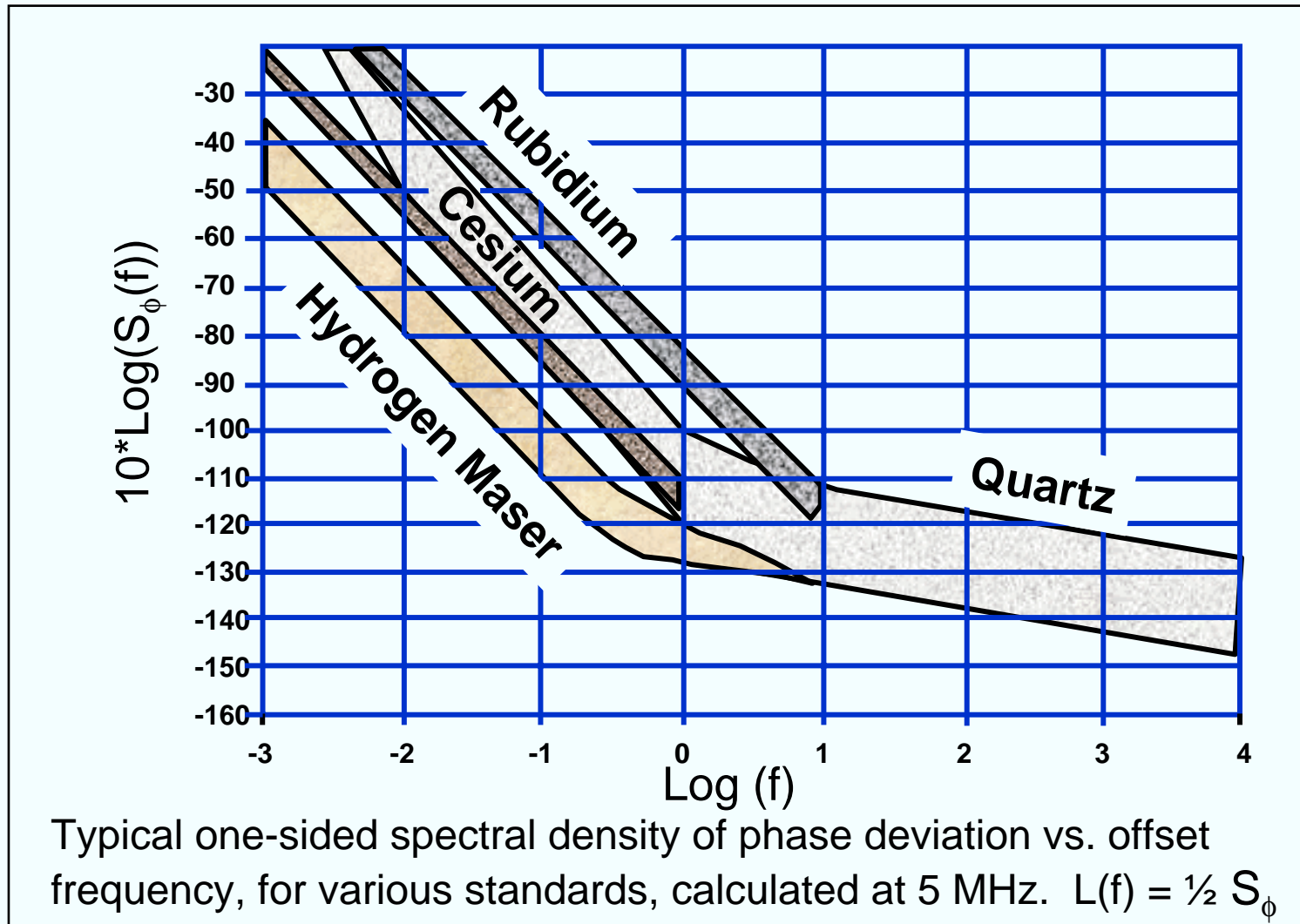

# Weaknesses and Wearout Mechanisms

	<b>Weaknesses</b>	<b>Wearout Mechanisms</b>
Quartz	Aging Rad hardness	None
Rubidium	Life Power Weight	Rubidium depletion Buffer gas depletion Glass contaminants
Cesium	Life Power Weight Cost Temp. range	Cesium supply depletion Spent cesium gettering Ion pump capacity Electron multiplier

# Why Do Crystal Oscillators Fail?

Crystal oscillators have no **inherent** failure mechanisms. Some have operated for decades without failure. Oscillators do fail (go out of spec.) occasionally for reasons such as:

- Poor workmanship & quality control - e.g., wires come loose at poor quality solder joints, leaks into the enclosure, and random failure of components
- Frequency ages to outside the calibration range due to high aging plus insufficient tuning range
- TCXO frequency vs. temperature characteristic degrades due to aging and the “trim effect”.
- OCXO frequency vs. temperature characteristic degrades due to shift of oven set point.
- Oscillation stops, or frequency shifts out of range or becomes noisy at certain temperatures, due to activity dips
- Oscillation stops or frequency shifts out of range when exposed to ionizing radiation - due to use of unswept quartz or poor choice of circuit components
- Oscillator noise exceeds specifications due to vibration induced noise
- Crystal breaks under shock due to insufficient surface finish



# Oscillator Selection Considerations

- Frequency accuracy or reproducibility requirement
- Recalibration interval
- Environmental extremes
- Power availability - must it operate from batteries?
- Allowable warmup time
- Short term stability (phase noise) requirements
- Size and weight constraints
- Cost to be minimized - acquisition or life cycle cost

# Crystal Oscillator Specification: MIL-PRF-55310

MIL-PRF-55310D  
15 March 1998

-----  
SUPERSEDING  
MIL-0-55310C  
15 Mar 1994

## PERFORMANCE SPECIFICATION OSCILLATOR, CRYSTAL CONTROLLED GENERAL SPECIFICATION FOR

This specification is approved for use by all Departments and Agencies of the Department of Defense.

### 1. SCOPE

1.1 Statement of scope. This specification covers the general requirements for quartz crystal oscillators used in electronic equipment.

-----  
Full text version is available via a link from <<http://www.ieee.org/uffc/fc>>

**CHAPTER 8**  
**Time and Timekeeping**

# What Is Time?

- "What, then, is time? If no one asks me, I know; if I wish to explain to him who asks, I know not." --- Saint Augustine, circa 400 A.D.
- The question, both a philosophical and a scientific one, has no entirely satisfactory answer. "Time is what a clock measures." "It defines the temporal order of events." "It is an element in the four-dimensional geometry of space-time." "It is nature's way of making sure that everything doesn't happen at once."
- Why are there "arrows" of time? The arrows are: entropy, electromagnetic waves, expansion of the universe, k-meson decay, and psychological. Does time have a beginning and an end? (Big bang; no more "events", eventually.)
- The unit of time, the second, is one of the seven base units in the International System of Units (SI units)\*. Since time is the quantity that can be measured with the highest accuracy, it plays a central role in metrology.

# Dictionary Definition of "Time"

(From The Random House Dictionary of the English Language ©1987)

**time** (tim), n., *adj.*, *u.*, *timed*, *tim-ing*. — n. 1. the system of those sequential relations that any event has to any other, as past, present, or future, indefinite and continuous duration regarded as that in which events succeed one another. 2. duration regarded as belonging to the present life as distinct from the life to come or from eternity; finite duration. 3. (*sometimes cap.*) a system or method of measuring or reckoning the passage of time: *mean time*; *apparent time*; Greenwich Time. 4. a limited period or interval, as between two successive events: a *long time*. 5. a particular period considered as distinct from other periods: *Youth is the best time of life*. 6. Often, times. a. a period in the history of the world, or contemporary with the life or activities of a notable person: prehistoric times; *in Lincoln's time*. b. the period or era now or previously present: *a sign of the times*; How times have changed! c. a period considered with reference to its events or prevailing conditions, tendencies Ideas, etc.: *hard times*; *a time of war*. 7. a prescribed or allotted period, as of one's life, for payment of a debt, etc. 8. the end of a prescribed or allotted period, as of one's life or a pregnancy: *His time had come, but there was no one left to mourn over him. When her time came, her husband accompanied her to the delivery room*. 9. a period with reference to personal experience of a specified kind: to have a good time; a hot time in the *old town* tonight. 10. a period of work of an employee, or the pay for it; working hours or days or an hourly or daily pay rate. 11. *Informal*. a term of enforced duty or imprisonment: to serve time *in the army*, do time *in prison*. 12. the period necessary for or occupied by something: *The time of the baseball game was two hours and two minutes. The bus takes too much time, so I'll take a plane*. 13. *leisure time*; *sufficient or spare time*: *to have time for a vacation*; *I have no time to stop now*. 14. a particular or definite point in time, as indicated by a clock: What time is it? 15. a particular part of a year, day, etc.; season or period: *It's time for lunch*. 16. an appointed, fit, due, or proper instant or period: *A time for sowing*; *the time when the sun crosses the meridian* There is A time for everything. 17. the particular point in time when an event is scheduled to take place: *train time*; *curtain time*. 18. an indefinite, frequently prolonged period or duration in the future: *Time will tell if what we have done here today was right*. 19. the right occasion or opportunity: to watch one's time. 20. each occasion of a recurring action or event: to do a thing *five times*, *It's*

the *pitcher's time* at bat. 21. times, used as a multiplicative word in phrasal combinations expressing how many instances of a quantity or factor are taken together: *Two goes into six three times, five times faster* 22. Drama. *one of the three unities*. Cf. unity (def. 8) 23. Pros. a unit or a group of units in the measurement of meter. 24. Music a. tempo, relative rapidity of movement. b. the metrical duration of a note or rest. c. proper or characteristic tempo. d. the general movement of a particular kind of musical composition with reference to its rhythm, metrical structure, and tempo. e. the movement of a dance or the like to music so arranged: waltz time. 25. Mil. rate of marching, calculated on the number of paces taken per minute: *double time*; *quick time*. 26. Manège. each completed action or movement of the horse. 27. against time, in an effort to finish something within a limited period: *We worked against time to get out the newspaper*. 28. ahead of time, before the time due; early: *The building was completed ahead of time*. 29. at one time, a. once; in a former time: *At one time they owned a restaurant*. b. at the same time; at once: *They all tried to talk at one time*. 30. at the same time, nevertheless; yet: *I'd like to try it but at the same time I'm a little afraid* 31. at times at intervals; occasionally: *At times the city becomes intolerable*. 32. beat someone's time. Slang. to compete for or win a person being dated or courted by another; prevail over a rival: *He accused me, his own brother, of trying to beat his time*. 33. behind the times, old-fashioned; dated: These attitudes are *behind the times*. 34. for the time being, temporarily; for the present: *Let's forget about it for the time being*. 35. from time to time, on occasion; occasionally; at intervals: *She comes to see us from time to time*. 36. gain time, to postpone in order to make preparations or gain an advantage delay the outcome of: He *hoped* to gain time by putting off signing the papers for a few days more. 37. in good time, a. at the right time; on time, punctually. b. in advance of the right time; early: *We arrived at the appointed spot in good time*. 38. in no time, in a very brief time; almost at once: *Working together, they cleaned the entire house in no time*. 39. in time, a. early enough: to come in time for dinner. b. in the future; eventually: *In time he'll see what is right*. c. in the correct rhythm or tempo: *There would always be at least one child who couldn't play in time with the music* 40. keep time, a. to record time, as a watch or clock

does h to mark or observe the tempo. c. to perform rhythmic movements in unison. 41. kill time, to occupy oneself with some activity to make time pass quickly: *While I was waiting, I killed time counting the cars on the freight trains*. 42. make time, a. to move quickly, esp. in an attempt to recover lost time. b. to travel at a particular speed. 43. make time with, Slang. to pursue or take as a sexual partner. 44. many a time, again and again; frequently: *Many a time they didn't have enough to eat and went to bed hungry*. 45. mark time, a. to suspend progress temporarily, as to await developments; fail to advance. b. Mil. to move the feet alternately as in marching, but without advancing. 46. on one's own time, during one's free time; without payment: *He worked out more efficient production methods on his own time*. 47. on time, a. at the specified time; punctuaBy. b. to be paid for within a designated period of time, as in installments: *Many people are never out of debt because they buy everything on time*. 48. out of time, not in the proper rhythm: *His singing was out of time with the music* 49. Pass the time of day, to converse briefly with or greet someone: *The women would stop in the market to pass the time of day*. 50. take one's time, to be slow or leisurely; dawdle: *Speed was important here, but he just took his time*. 51. time after time, again and again; repeatedly; often: *I've told him time after time not to slam the door*. 52. time and time again, repeatedly; often: *Time and time again I warned her to stop smoking*. Also, time and again. 53. time of life, (one's) age: *At your time of life you must be careful not to overdo things*. 54. time of one's life, *Informal*. an extremely enjoyable experience: *They had the time of their lives on their trip to Europe*. 55. of, pertaining to, or showing the passage of time 56. (of an explosive device) containing a clock so that it will detonate at the desired moment a time bomb 57. Com. payable at a stated period of time after presentment: *time drafts or notes*. 58. of or pertaining to purchases on the installment plan, or with payment postponed. v.t. 59. to measure or record the speed, duration, or rate of: to time a race. 60. to fix the duration of: *The proctor timed the test at 16 minutes*. 61. to fix the interval between (actions, events, etc.): *They timed their strokes at six per minute*. 62. to regulate (a train, clock etc.) as to time. 63. to appoint or choose the moment or occasion for; schedule: *He timed the attack perfectly*. — v.i. 64. to keep time; sound or move in unison. [bef. 900; (n.)

# The Second

- The SI unit of time is the second (symbol s).
- The second was defined, by international agreement, in October, 1967, at the XIII General Conference of Weights and Measures.
- **The second is "the duration of 9,192,631,770 periods of the radiation corresponding to the transition between the two hyperfine levels of the ground state of the cesium atom 133."**
- Prior to 1967, the unit of time was based on astronomical observations; the second was defined in terms of ephemeris time, i.e., as "1/31,556,925.9747 of the tropical year..."
- The unit of frequency is defined as the hertz (symbol Hz). One hertz equals the repetitive occurrence of one "event" per second.

# Frequency and Time

$$f = \frac{1}{\tau}$$

where  $f$  = frequency (= number of “events” per unit time), and  
 $\tau$  = period (= time between “events”)

$$\text{Accumulated clock time} = \frac{\text{Total number of events}}{\text{Number of events per unit of time}}$$

$$\text{Example : } \frac{3 \text{ rotations of the earth}}{1 \text{ rotation/day}} = 3 \text{ days}$$

Frequency source + counting mechanism → clock

Examples of frequency sources: the rotating earth, pendulum, quartz crystal oscillator, and atomic frequency standard.

# Typical Clock System

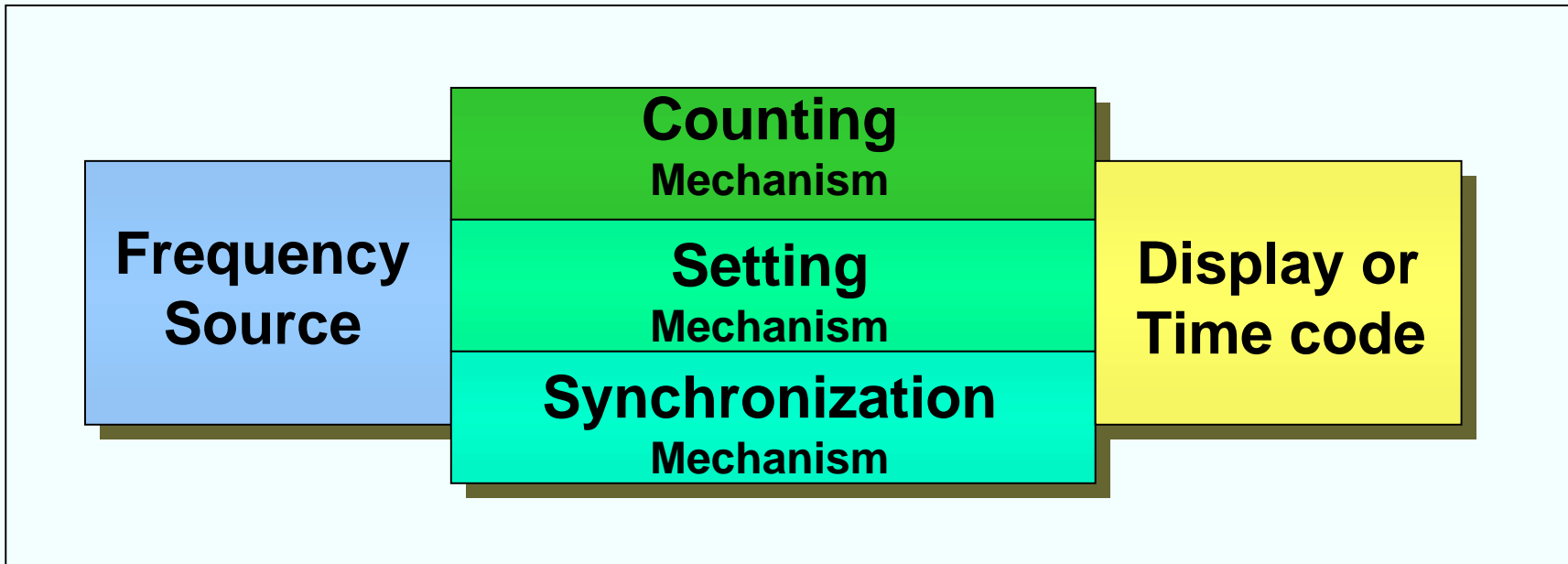

$$t = t_0 + \Sigma \Delta\tau$$

Where  $t$  is the time output,  $t_0$  is the initial setting, and  $\Delta\tau$  is the time interval being counted.



# Evolution of Clock Technologies

- Sundials, and **continuous flow** of:
  - Water (clepsydra)
  - Sand (hour glass)
  - Falling weights, with frictional control of rate
- Vibrating, but **non-resonant motion** - escapement mechanisms: falling weight applies torque through train of wheels; rate control depends on moments of inertia, friction and torque; period is the time it takes to move from one angular position to another.
- **Resonant control**
  - Mechanical: pendulum, hairspring and balance wheel
  - Mechanical, electrically driven: tuning fork, quartz resonator
  - Atomic and molecular

# Progress in Timekeeping

Time Period	Clock/Milestone	Accuracy Per Day
4th millennium B.C.	Day & night divided into 12 equal hours	
Up to 1280 A.D.	Sundials, water clocks (clepsydrae)	~1 h
~1280 A.D.	Mechanical clock invented- assembly time for prayer was first regular use	~30 to 60 min
14th century	Invention of the escapement; clockmaking becomes a major industry	~15 to 30 min
~1345	Hour divided into minutes and seconds	
15th century	Clock time used to regulate people's lives (work hours)	~2 min
16th century	Time's impact on science becomes significant (Galileo times physical events, e.g., free-fall)	~1 min
1656	First pendulum clock (Huygens)	~100 s
18th century	Temperature compensated pendulum clocks	1 to 10 s
19th century	Electrically driven free-pendulum clocks	$10^{-2}$ to $10^{-1}$ s
~1910 to 1920	Wrist watches become widely available	
1920 to 1934	Electrically driven tuning forks	$10^{-3}$ to $10^{-2}$ s
1921 to present	Quartz crystal clocks (and watches. Since ~1971)	$10^{-5}$ to $10^{-1}$ s
1949 to present	Atomic clocks	$10^{-9}$ to $10^{-4}$ s

# Clock Errors

$$T(t) = T_0 + \int_0^t R(t)dt + \varepsilon(t) = T_0 + (R_0t + 1/2At^2 + \dots) + \int_0^t E_i(t)dt + \varepsilon(t)$$

Where,

$T(t)$  = time difference between two clocks at time  $t$  after synchronization

$T_0$  = synchronization error at  $t = 0$

$R(t)$  = the rate (i.e., fractional frequency) difference between the two clocks under comparison;  $R(t) = R_0 + At + \dots E_i(t)$

$\varepsilon(t)$  = error due to random fluctuations =  $\tau\sigma_y(\tau)$

$R_0 = R(t)$  at  $t = 0$

$A$  = aging term (higher order terms are included if the aging is not linear)

$E_i(t)$  = rate difference due to environmental effects (temperature, etc.)

-----

**Example:** If a watch is set to within 0.5 seconds of a time tone ( $T_0 = 0.5$  s), and the watch initially gains 2 s/week ( $R_0 = 2$  s/week), and the watch rate ages -0.1 s per week<sup>2</sup>, ( $A = -0.1$  s/week<sup>2</sup>), then after 10 weeks (and assuming  $E_i(t) = 0$ ):

$T(10 \text{ weeks}) = 0.5 (2 \times 10) + 1/2(-0.1 \times (10)^2) = 15.5$  seconds.

# Frequency Error vs. Time Error

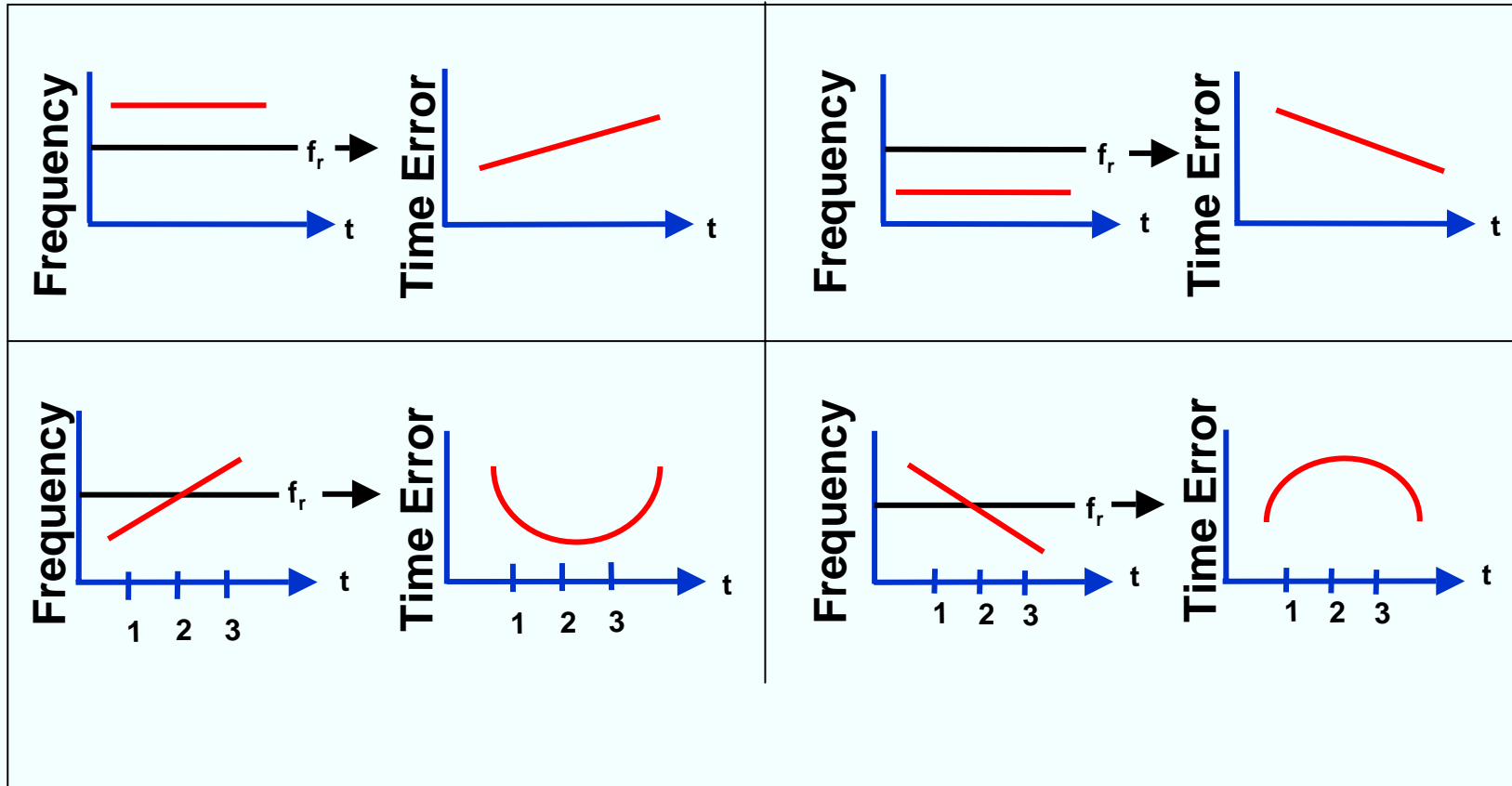

$f_r$  = reference (i.e., the “correct”) frequency

# Clock Error vs. Resynchronization Interval

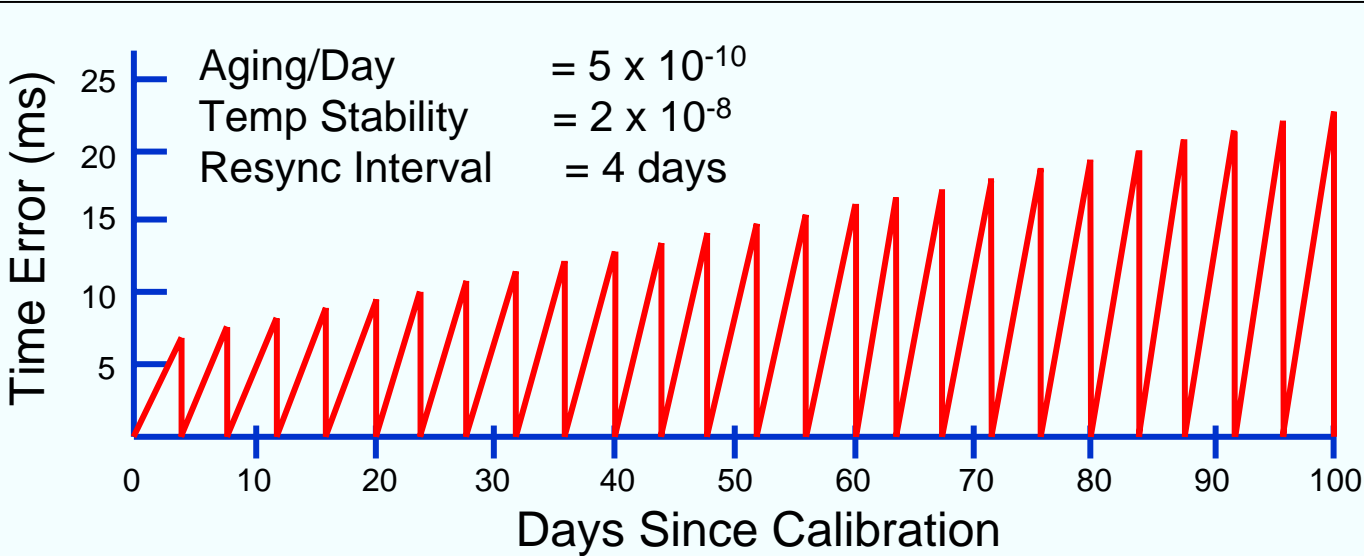

	TCXO		OCXO		MCXO		RbXO	
Avg. Temp. Stab.	$1 \times 10^{-6}$		$2 \times 10^{-8}$		$2 \times 10^{-8}$		$2 \times 10^{-8}$	
Aging/Day	$1 \times 10^{-8}$		$1 \times 10^{-10}$		$5 \times 10^{-11}$		$5 \times 10^{-13}$	
Resynch Interval* (A/J & security)	10 min	4 hrs	6 hours	4 days	6 hours	4 days	6 hours	4 days
Recalibr. Interval * (Maintenance cost)	10 yrs	80 days	50 years	1.5 yrs	94 yrs	3 yrs	None needed	300 yrs

\* Calculated for an accuracy requirement of 25 milliseconds. Many modern systems need much better.

# Time Error vs. Elapsed Time

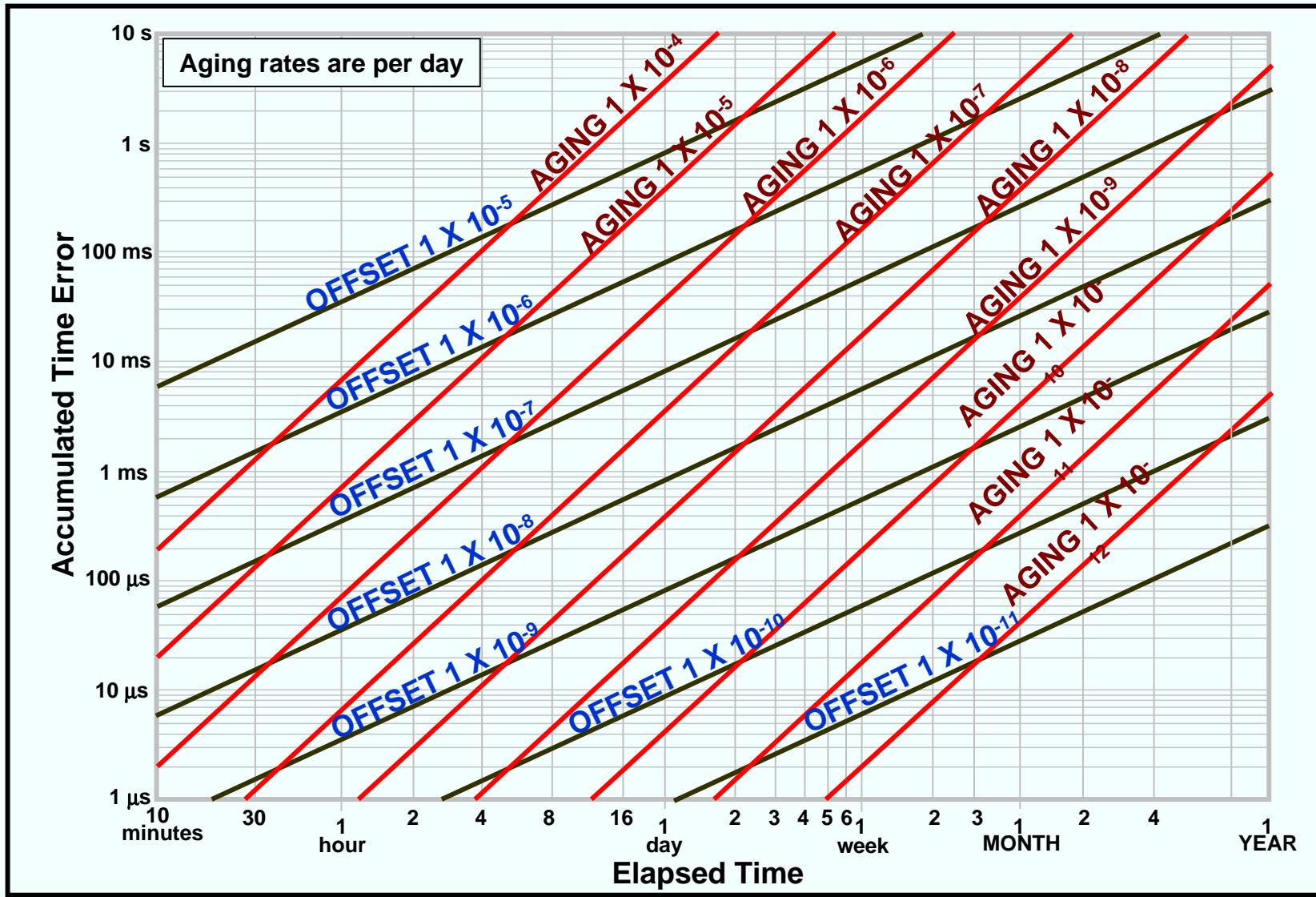

# On Using Time for Clock Rate Calibration

It takes time to measure the clock rate (i.e., frequency) difference between two clocks. The smaller the rate difference between a clock to be calibrated and a reference clock, the longer it takes to measure the difference ( $\Delta t/t \approx \Delta f/f$ ).

For example, assume that a reference timing source (e.g., Loran or GPS) with a time uncertainty of 100 ns is used to calibrate the rate of a clock to  $1 \times 10^{-11}$  accuracy. A frequency offset of  $1 \times 10^{-11}$  will produce  $1 \times 10^{-11} \times 3600 \text{ s/hour} = 36 \text{ ns}$  time error per hour. Then, to have a high certainty that the measured time difference is due to the frequency offset rather than the reference clock uncertainty, one must accumulate a sufficient amount ( $\geq 100 \text{ ns}$ ) of time error. It will take hours to perform the calibration. (See the next page for a different example.) If one wishes to know the frequency offset to a  $\pm 1 \times 10^{-12}$  precision, then the calibration will take more than a day.

Of course, if one has a cesium standard for frequency reference, then, for example, with a high resolution frequency counter, one can make frequency comparisons of the same precision much faster.

# Calibration With a 1 pps Reference

Let

- $A$  = desired clock rate accuracy after calibration
- $A'$  = actual clock rate accuracy
- $\Delta\tau$  = jitter in the 1 pps of the reference clock, rms
- $\Delta\tau'$  = jitter in the 1 pps of the clock being calibrated, rms
- $t$  = calibration duration
- $\Delta t$  = accumulated time error during calibration

Then, what should be the  $t$  for a given set of  $A$ ,  $\Delta t$ , and  $\Delta t'$ ?

**Example:** The crystal oscillator in a clock is to be calibrated by comparing the 1 pps output from the clock with the 1 pps output from a standard. If  $A = 1 \times 10^{-9}$ ;  $\Delta\tau = 0.1 \mu\text{s}$ , and  $\Delta\tau' = 1.2 \mu\text{s}$ , then,  $[(\Delta\tau)^2 + (\Delta\tau')^2]^{1/2} \approx 1.2 \mu\text{s}$ , and when  $A = A'$ ,  $\Delta t = (1 \times 10^{-9})t \equiv (1.2 \mu\text{s})N$ , and  $t = (1200N) \text{ s}$ . The value of  $N$  to be chosen depends on the statistics of the noise processes, on the confidence level desired for  $A'$  to be  $\leq A$ , and on whether one makes measurements every second or only at the end points. If one measures at the end points only, and the noise is white phase noise, and the measurement errors are normally distributed, then, with  $N = 1$ , 68% of the calibrations will be within  $A$ ; with  $N = 2$ , and 3, 95% and 99.7%, respectively, will be within  $A$ . One can reduce  $t$  by about a factor  $2/N^{3/2}$  by making measurements every second; e.g., from 1200 s to  $2 \times (1200)^{2/3} = 225 \text{ s}$ .



# Time Transfer Methods

Method	Accuracy	~ Cost ('95)
Portable Cs clock	10 - 100 ns	\$45K - 70K
GPS time dissemination	20 - 100 ns	\$100 - 5K
GPS common view	5 - 20 ns	
Two-way via satellite	~1 ns	\$60k
Loran-C	100 ns	\$1K - 5K
HF (WWV)	2 ms	\$100 - 5K
Portable quartz & Rb clocks	Calibration interval dependent	\$200 - 2K

# Global Positioning System (GPS)

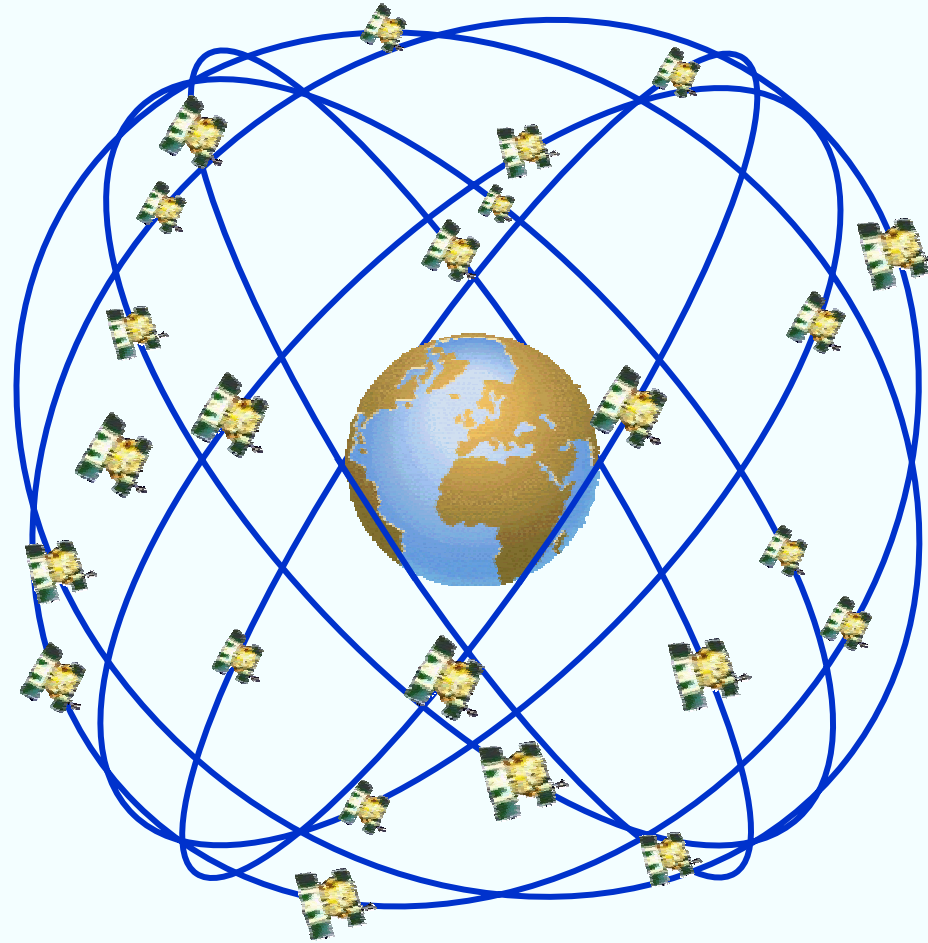

**GPS Nominal Constellation:**  
24 satellites in 6 orbital planes,  
4 satellites in each plane,  
20,200 km altitude, 55 degree inclinations

# GPS

GPS can provide global, all-weather, 24-hour, real-time, accurate navigation and time reference to an unlimited number of users.

- **GPS Accuracies ( $2\sigma$ )**

<b>Position:</b>	120 m for Standard Positioning Service, SPS 40 m for Precise Positioning Service, PPS 1 cm + 1ppm for differential, static land survey
<b>Velocity:</b>	0.3 m/s (SPS), 0.1 m/s (PPS).
<b><u>Time:</u></b>	<u>350 ns to &lt; 10 ns</u>

- 24 satellites in 6 orbital planes; 6 to 10 visible at all times; ~12 h period  
20,200 km orbits.
- Pseudorandom noise (PRN) navigation signals are broadcast at L1 = 1.575 GHz (19 cm) and L2 = 1.228 GHz (24 cm); two codes, C/A and P are sent; messages provide satellite position, time, and atmospheric propagation data; receivers select the optimum 4 (or more) satellites to track. PPS (for DoD users) uses L1 and L2, SPS uses L1 only.

# Oscillator's Impact on GPS

- Satellite oscillator's (clock's) inaccuracy & noise are major sources of navigational inaccuracy.
- Receiver oscillator affects GPS performance, as follows:

<u>Oscillator Parameter</u>	<u>GPS Performance Parameter</u>
Warmup time	Time to first fix
Power	Mission duration, logistics costs (batteries)
Size and weight	Manpack size and weight
Short term stability (0.1 s to 100 s)	$\Delta$ range measurement accuracy, acceleration performance, jamming resistance
Short term stability (~15 minute)	Time to subsequent fix
Phase noise	Jamming margin, data demodulation, tracking
Acceleration sensitivity	See short term stability and phase noise effects

# Time Scales

- A "**time scale**" is a system of assigning dates, i.e., a "time," to events; e.g., 6 January 1989, 13 h, 32 m, 46.382912 s, UTC, is a date.
- A "**time interval**" is a "length" of time between two events; e.g., five seconds.
- **Universal time** scales, UT0, UT1, and UT2, are based on the earth's spin on its axis, with corrections.
- Celestial navigation: clock (UT1) + sextant  $\longrightarrow$  position.
- **International Atomic Time (TAI)** is maintained by the International Bureau of Weights and Measures (BIPM; in France), and is derived from an ensemble of more than 200 atomic clocks, from more than 60 laboratories around the world.
- **Coordinated Universal Time (UTC)** is the time scale today, by international agreement. The rate of UTC is determined by TAI, but, in order to not let the time vs. the earth's position change indefinitely, UTC is adjusted by means of leap seconds so as to keep UTC within 0.9 s of UT1.

# Clock Ensembles and Time Scales

- An ensemble of clocks is a group of clocks in which the time outputs of individual clocks are combined, via a “time-scale algorithm,” to form a time scale.
- Ensembles are often used in mission critical applications where a clock’s failure (or degraded performance) presents an unacceptable risk.
- Advantages of an ensemble:
  - system time & frequency are maintained even if a clock in the ensemble fails
  - ensemble average can be used to estimate the characteristics of each clock; outliers can be detected
  - performance of ensemble can (sometimes) be better than any of the contributors
  - a proper algorithm can combine clocks of different characteristics, and different duty cycles, in an optimum way

# Relativistic Time

- Time is not absolute. The "time" at which a distant event takes place depends on the observer. For example, if two events, **A** and **B**, are so close in time or so widely separated in space that no signal traveling at the speed of light can get from one to the other before the latter takes place, then, even after correcting for propagation delays, it is possible for one observer to find that **A** took place before **B**, for a second to find that **B** took place before **A**, and for a third to find that **A** and **B** occurred simultaneously. Although it seems bizarre, all three can be right.
- Rapidly moving objects exhibit a "time dilation" effect. ("Twin paradox": Twin on a spaceship moving at  $0.87c$  will age 6 months while twin on earth ages 1 year. There is no "paradox" because spaceship twin must accelerate; i.e., there is no symmetry to the problem.)
- A clock's rate also depends on its position in a gravitational field. A high clock runs faster than a low clock.

# Relativistic Time Effects

- Transporting "perfect" clocks slowly around the surface of the earth along the equator yields  $\Delta t = -207$  ns eastward and  $\Delta t = +207$  ns westward (portable clock is late eastward). The effect is due to the earth's rotation.
- At latitude  $40^\circ$ , for example, the rate of a clock will change by  $1.091 \times 10^{-13}$  per kilometer above sea level. Moving a clock from sea level to 1km elevation makes it gain 9.4 nsec/day at that latitude.
- In 1971, atomic clocks flown eastward then westward around the world in airlines demonstrated relativistic time effects; eastward  $\Delta t = -59$  ns, westward  $\Delta t = +273$  ns; both values agreed with prediction to within the experimental uncertainties.
- Spacecraft Examples:
  - For a space shuttle in a 325 km orbit,  $\Delta t = t_{\text{space}} - t_{\text{ground}} = -25$   $\mu\text{sec/day}$
  - For GPS satellites (12 hr period circular orbits),  $\Delta t = +44$   $\mu\text{sec/day}$
- In precise time and frequency comparisons, relativistic effects must be included in the comparison procedures.



# Relativistic Time Corrections

The following expression accounts for relativistic effects, provides for clock rate accuracies of better than 1 part in  $10^{14}$ , and allows for global-scale clock comparisons of nanosecond accuracy, via satellites:

$$\Delta t = -\frac{1}{c^2} \int_0^T \left[ \frac{1}{2} (v_s^2 - v_g^2) - (\Phi_s - \Phi_g) \right] dt + \frac{2\omega}{c^2} A_E$$

Where  $\Delta t$  = time difference between spacecraft clock and ground clock,  $t_s - T_g$

$V_s$  = spacecraft velocity ( $\ll c$ ),  $V_g$  = velocity of ground station

$\Phi_s$  = gravitational potential at the spacecraft

$\Phi_g$  = gravitational potential at the ground station

$\omega$  = angular velocity of rotation of the earth

$A_E$  = the projected area on the earth's equatorial plane swept out by the vector whose tail is at the center of the earth and whose head is at the position of the portable clock or the electromagnetic signal pulse. The  $A_E$  is taken positive if the head of the vector moves in the eastward direction.

Within 24 km of sea level,  $\Phi = gh$  is accurate to  $1 \times 10^{-14}$  where  $g = (9.780 + 0.052 \sin^2\Psi) \text{ m/s}^2$ ,  $\Psi$  = the latitude,  $h$  = the distance above sea level, and where the  $\sin^2\Psi$  term accounts for the centrifugal potential due to the earth's rotation. The "Sagnac effect,"  $(2\omega/c^2)A_E = (1.6227 \times 10^{-21} \text{ s/m}^2)A_E$ , accounts for the earth-fixed coordinate system being a rotating, noninertial reference frame.

# Some Useful Relationships

- Propagation delay = 1 ns/30 cm = 1 ns/ft = 3.3  $\mu$ s/km  $\approx$  5  $\mu$ s/mile
- 1 day = 86,400 seconds; 1 year = 31.5 million seconds
- Clock accuracy: 1 ms/day  $\approx$  1 x 10<sup>-8</sup>
- At 10 MHz: period = 100 ns; phase deviation of 1° = 0.3 ns of time deviation
- Doppler shift\* =  $\Delta f/f = 2v/c$

-----

\* **Doppler shift example:** if  $v = 4$  km/h and  $f = 10$  GHz (e.g., a slow-moving vehicle approaching an X-band radar), then  $\Delta f = 74$  Hz, i.e., an oscillator with low phase noise at 74Hz from the carrier is necessary in order to "see" the vehicle.

# One Pulse-Per-Second Timing Signal (MIL-STD-188-115)

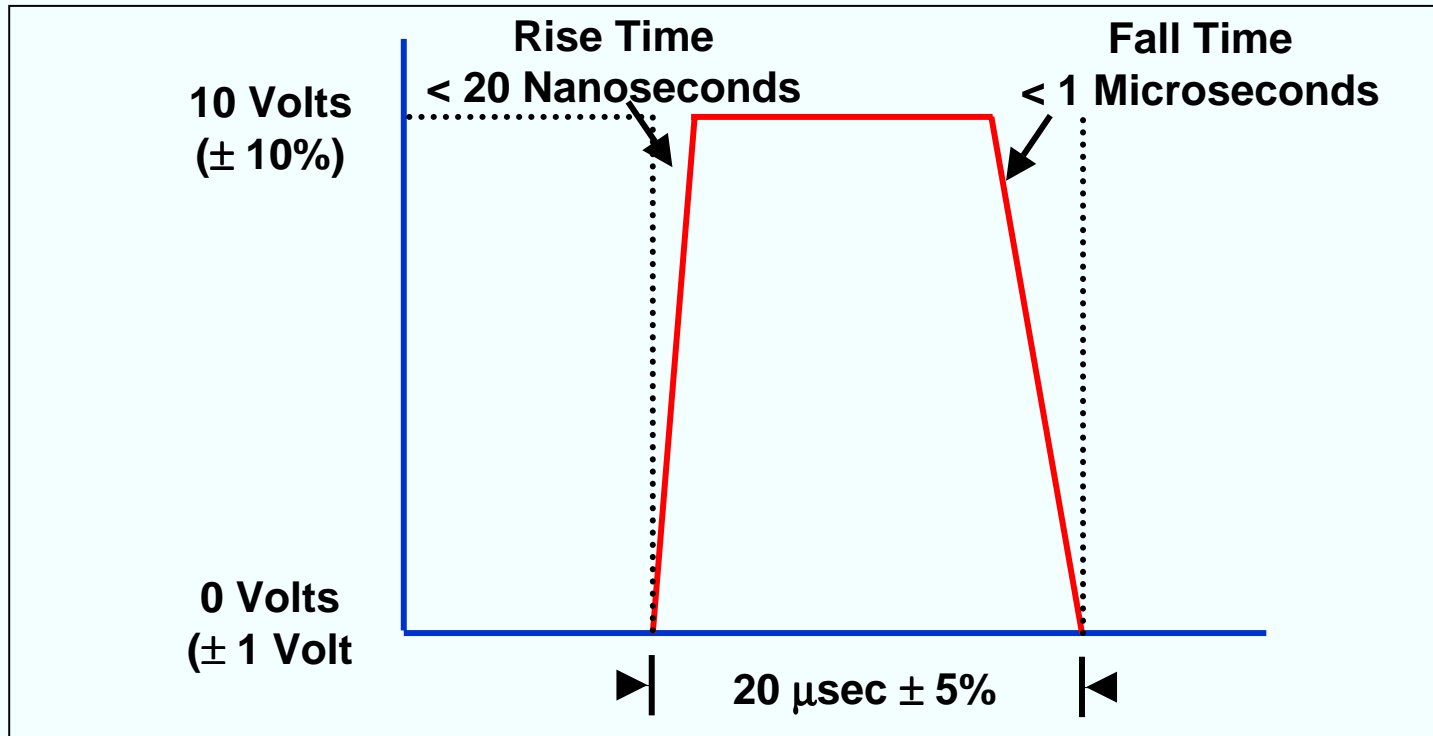

"The leading edge of the BCD code (negative going transitions after extended high level) shall coincide with the on-time (positive going transition) edge of the one pulse-per-second signal to within  $\pm 1$  millisecond." See next page for the MIL-STD BCD code.

# BCD Time Code

## (MIL-STD-188-115)

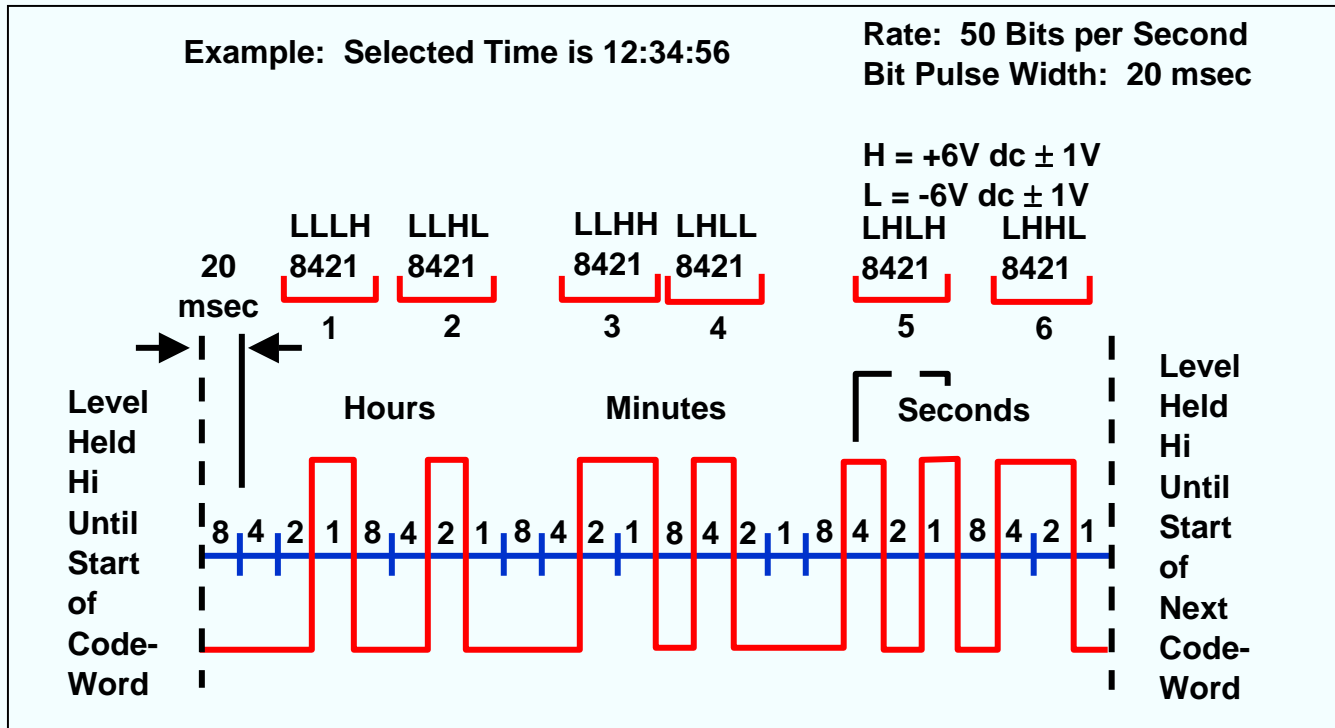

### 24 Bit BCD Time Code\*

\* May be followed by 12 bits for day-of-year and/or 4 bits for figure-of-merit (FOM). The FOM ranges from better than 1 ns (BCD character 1) to greater than 10 ms (BCD character 9).

# Time and Frequency Subsystem

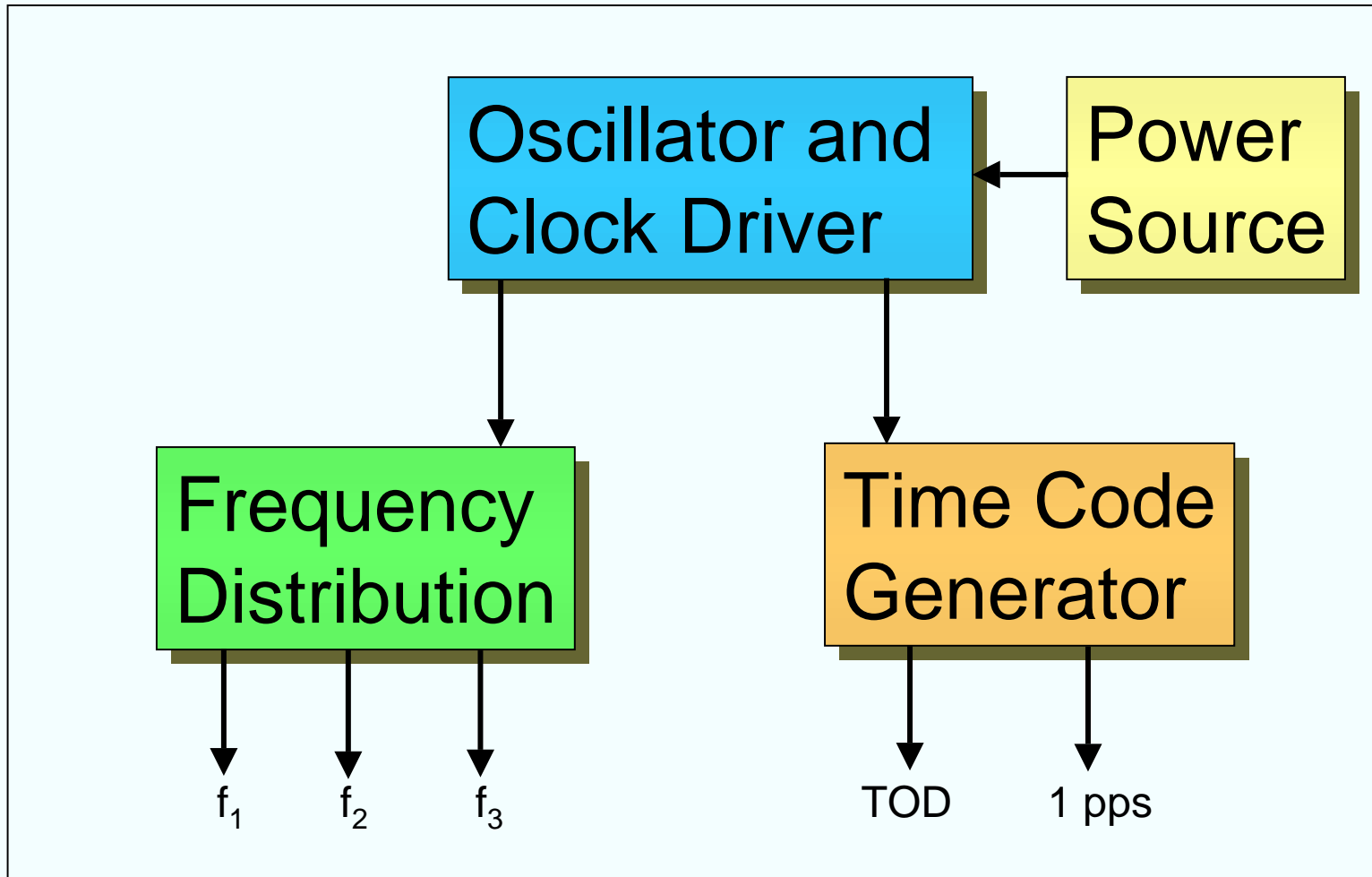

# The MIFTTI Subsystem

MIFTTI = Modular Intelligent Frequency, Time and Time Interval

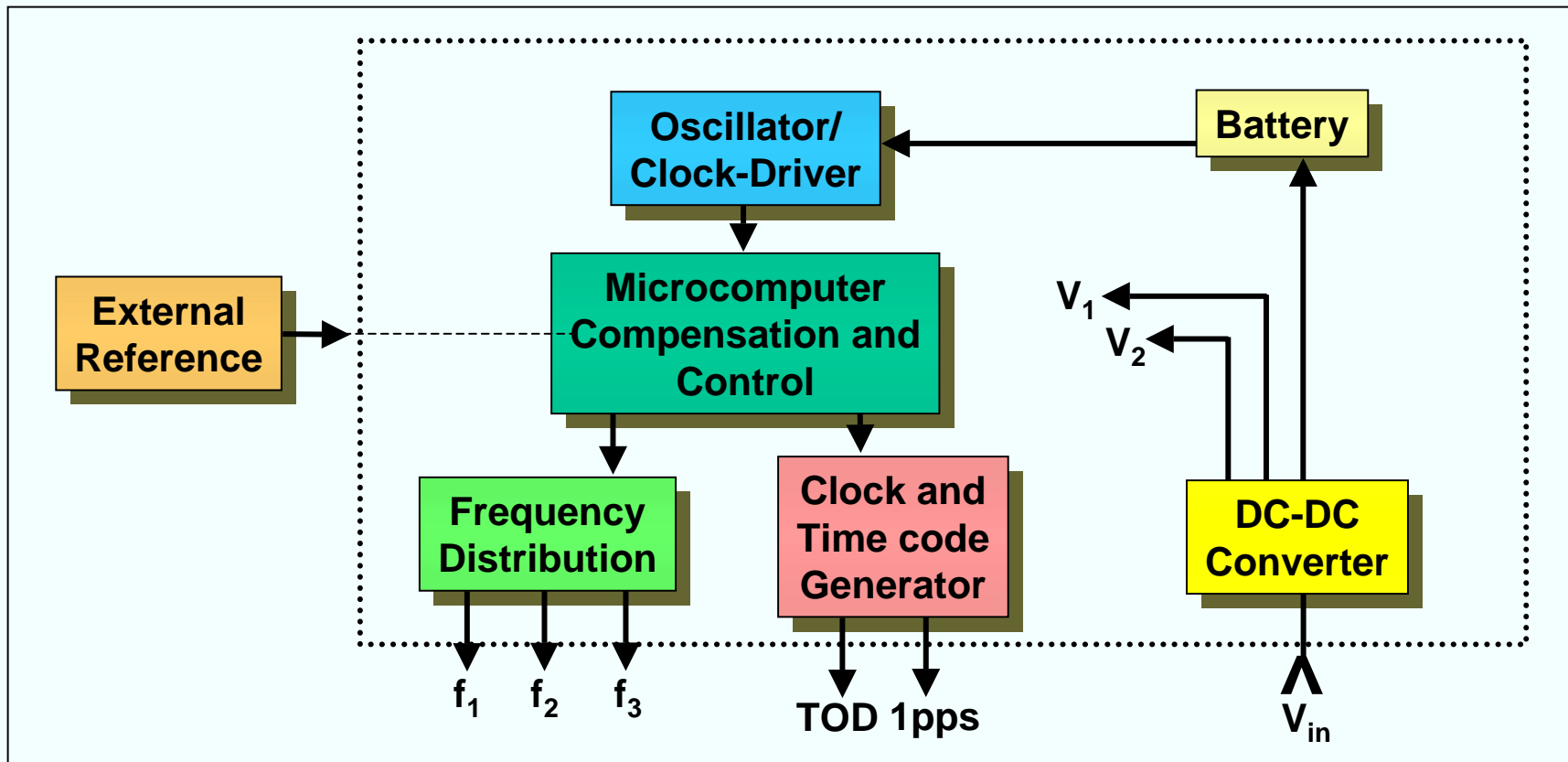

\* The microcomputer compensates for systematic effects (after filtering random effects), and performs: automatic synchronization and calibration when an external reference is available, and built-in-testing.

# "Time" Quotations

- 3 o'clock is always too late or too early for anything you want to do.....Jean-Paul Sartre
- Time ripens all things. No man's born wise.....Cervantes.
- Time is the rider that breaks youth.....George Herbert
- Time wounds all heels.....Jane Ace
- Time heals all wounds.....Proverb
- The hardest time to tell: when to stop.....Malcolm Forbes
- Time is on our side.....William E. Gladstone
- It takes time to save time.....Joe Taylor
- Time, whose tooth gnaws away everything else, is powerless against truth.....Thomas H. Huxley
- Time has a wonderful way of weeding out the trivial.....Richard Ben Sapir
- Time is a file that wears and makes no noise.....English proverb
- The trouble with life is that there are so many beautiful women - and so little time.....John Barrymore
- Life is too short, and the time we waste yawning can never be regained.....Stendahl
- Time goes by: reputation increases, ability declines.....Dag Hammarskjöld
- Remember that time is money.....Benjamin Franklin
- The butterfly counts not months but moments, and has time enough.....Rabindranath Tagore
- Everywhere is walking distance if you have the time.....Steven Wright
- The only true time which a man can properly call his own, is that which he has all to himself; the rest, though in some sense he may be said to live it, is other people's time, not his.....Charles Lamb
- It is familiarity with life that makes time speed quickly. When every day is a step in the unknown, as for children, the days are long with gathering of experience.....George Gissing
- Time is a great teacher, but unfortunately it kills all its pupils.....Hector Berlioz
- To everything there is a season, and a time to every purpose under the heaven.....Ecclesiastes 3:1
- Time goes, you say? Ah no! Time stays, we go.....Henry Austin Dobson
- Time is money - says the vulgarest saw known to any age or people. Turn it around, and you get a precious truth - Money is time.....George (Robert) Gissing

# Units of Measurement Having Special Names in the International System of Units (SI)

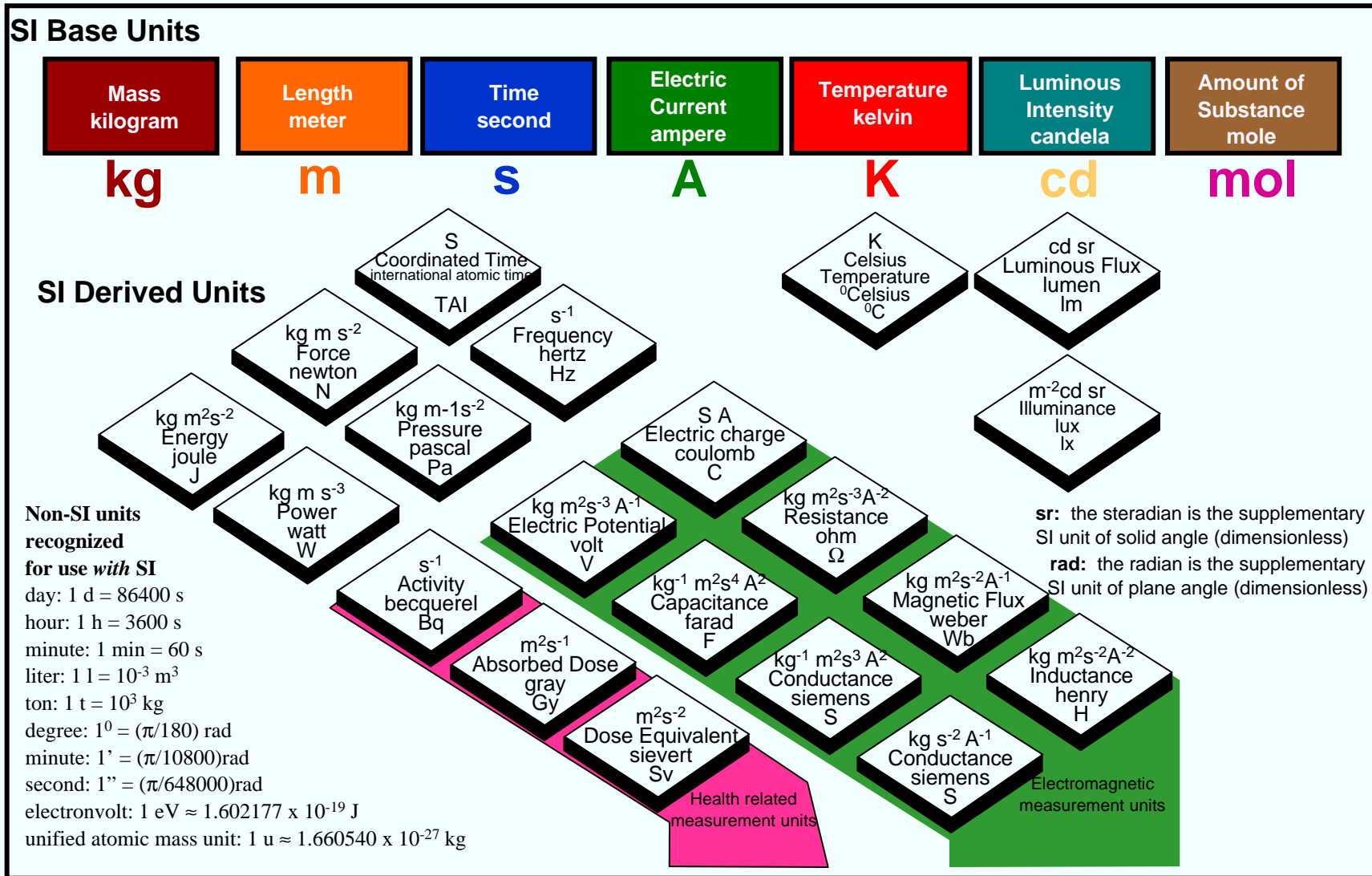



# Units of Measurement Having Special Names in the SI Units, NOT Needing Standard Uncertainty in SI Average Frequency

## SI Base Units

Mass  
kilogram

**kg**

Temperature  
kelvin

**K**

Amount of  
Substance  
mole

**mol**

## SI Derived Units

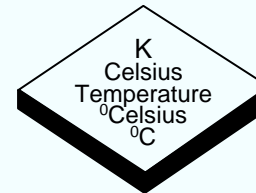

Non-SI units  
recognized  
for use *with* SI

ton:  $1 \text{ t} = 10^3 \text{ kg}$

degree:  $1^\circ = (\pi/180) \text{ rad}$

minute:  $1' = (\pi/10800) \text{ rad}$

second:  $1'' = (\pi/648000) \text{ rad}$

unified atomic mass unit:  $1 \text{ u} \approx 1.660540 \times 10^{-27} \text{ kg}$

**CHAPTER 9**  
**Related Devices and Application**

# Discrete-Resonator Crystal Filter

## A Typical Six-pole Narrow-band Filter

Layout

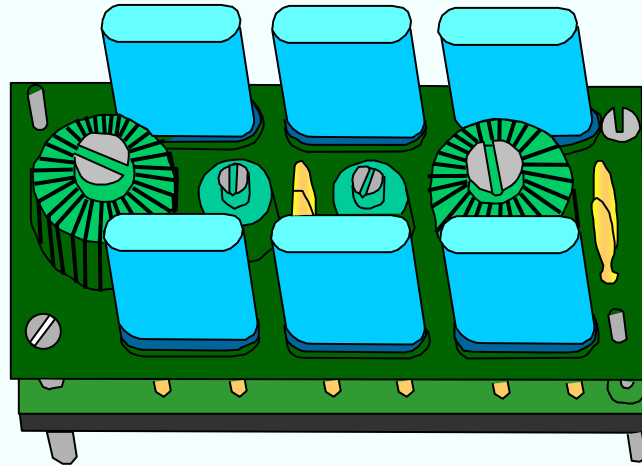

Circuit

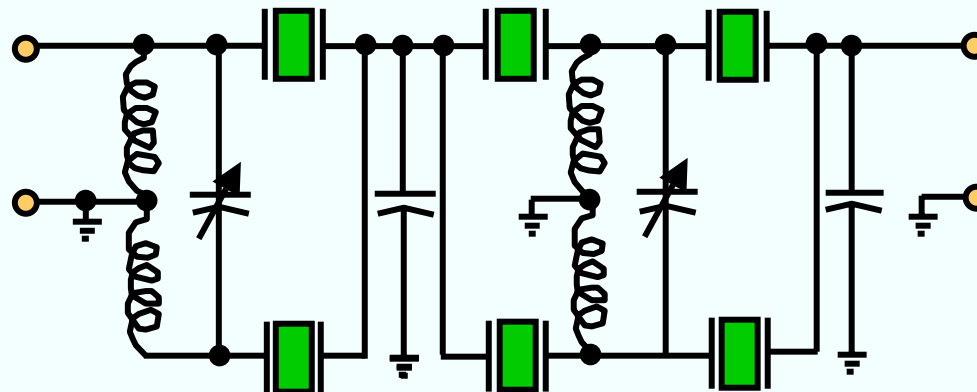

# Monolithic Crystal Filters

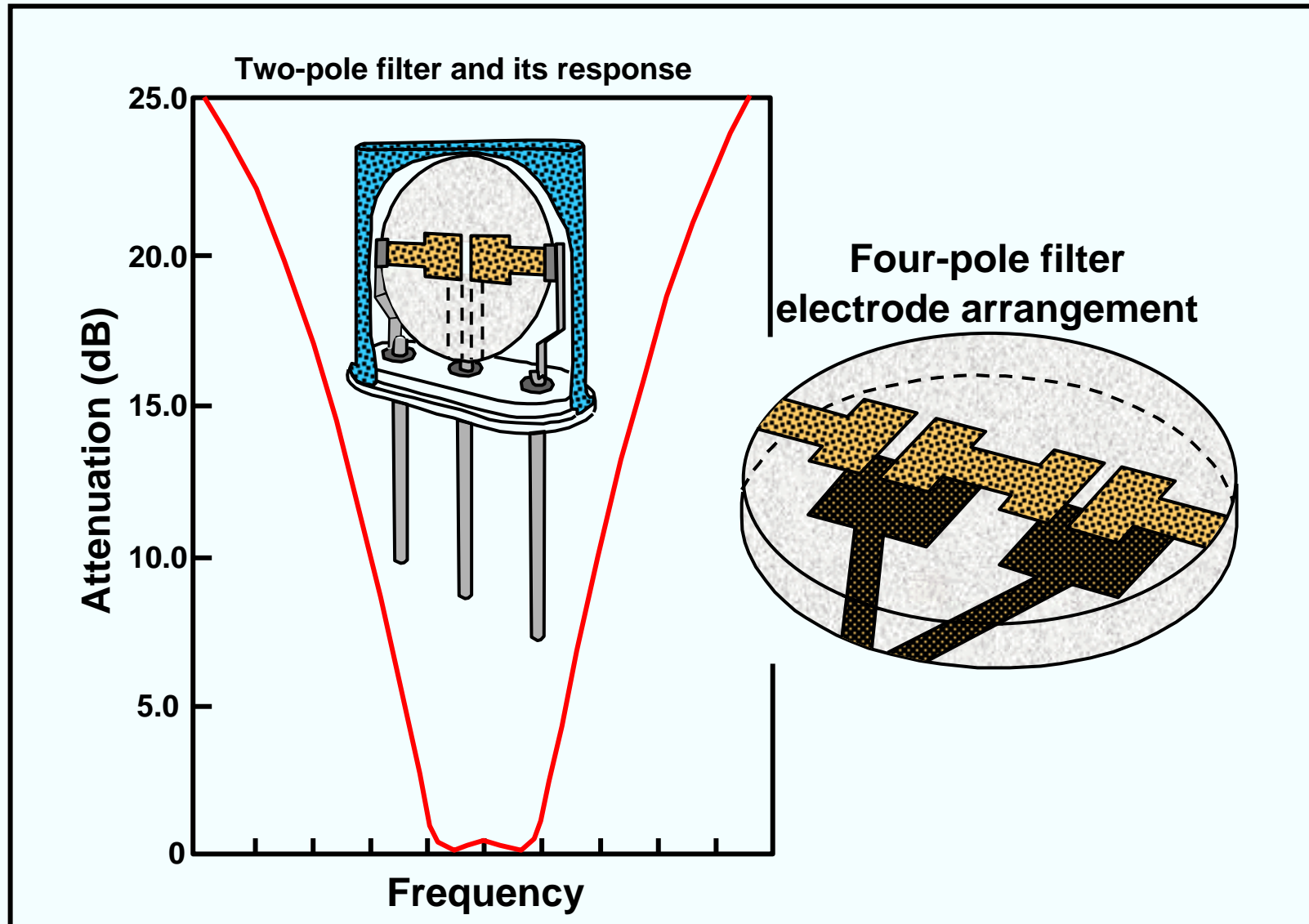

# Surface Acoustic Wave (SAW) Devices

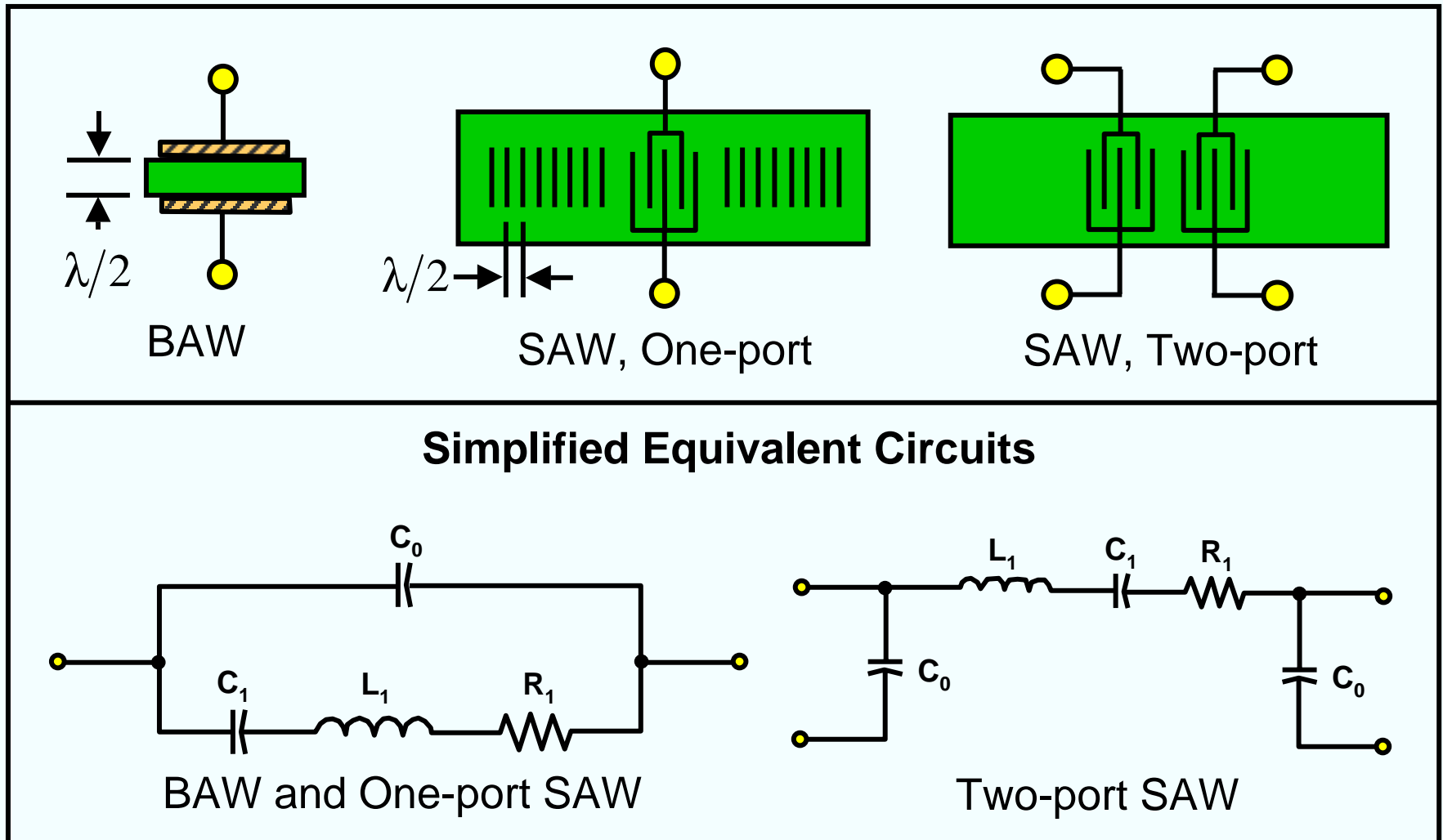

# Quartz Bulk-Wave Resonator Sensors

In frequency control and timekeeping applications, resonators are designed to have minimum sensitivity to environmental parameters. In sensor applications, the resonator is designed to have a high sensitivity to an environmental parameter, such as temperature, adsorbed mass, force, pressure and acceleration.

Quartz resonators' advantages over other sensor technologies are:

- High resolution and wide dynamic range (due to excellent short-term stability); e.g., one part in  $10^7$  ( $10^{-6}$  g out of 20 g) accelerometers are available, and quartz sorption detectors are capable of sensing  $10^{-12}$  grams.
- High long-term accuracy and stability, and
- Frequency counting is inherently digital.

# Tuning Fork Resonator Sensors

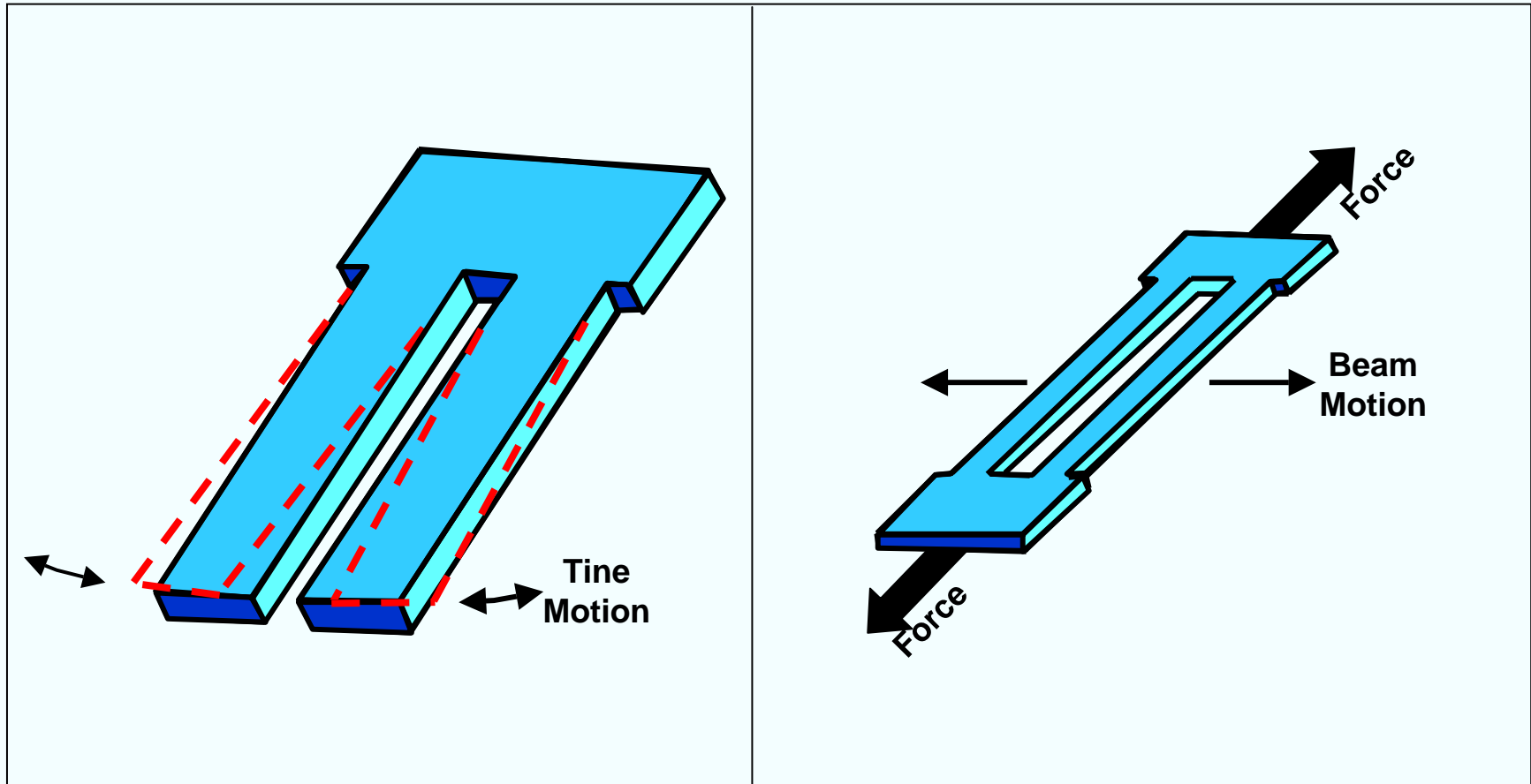

Photolithographically produced tuning forks, single- and double-ended (flexural-mode or torsional-mode), can provide low-cost, high-resolution sensors for measuring temperature, pressure, force, and acceleration. Shown are flexural-mode tuning forks.

# Dual Mode SC-cut Sensors

## •Advantages

- Self temperature sensing by dual mode operation allows separation/compensation of temp. effects
- Thermal transient compensated
- Isotropic stress compensated
- Fewer activity dips than AT-cut
- Less sensitive to circuit reactance changes
- Less sensitive to drive level changes

## •Disadvantage

- Severe attenuation in a liquid
- Fewer SC-cut suppliers than AT-cut suppliers



# Separation of Mass and Temperature Effects

- Frequency changes

$$\frac{\Delta f(m, T, x)}{f_o} = \frac{\Delta f(m)}{f_o} + \frac{\Delta f(T)}{f_o} + \frac{\Delta f(x)}{f_o}$$

total            mass            temperature            other effects

- Mass: adsorption and desorption

$$\frac{\Delta f(m)}{f_o} \cong -\frac{\Delta m}{m_o}$$

- Temperature/beat frequency

$$\frac{\Delta f(T)}{f_o} = \frac{\sum_i c_i \cdot \Delta f_{\beta}^i}{f_o} \quad f_{\beta} \equiv 3f_{c1}(T) - f_{c3}(T)$$

# Dual-Mode Pressure Sensor

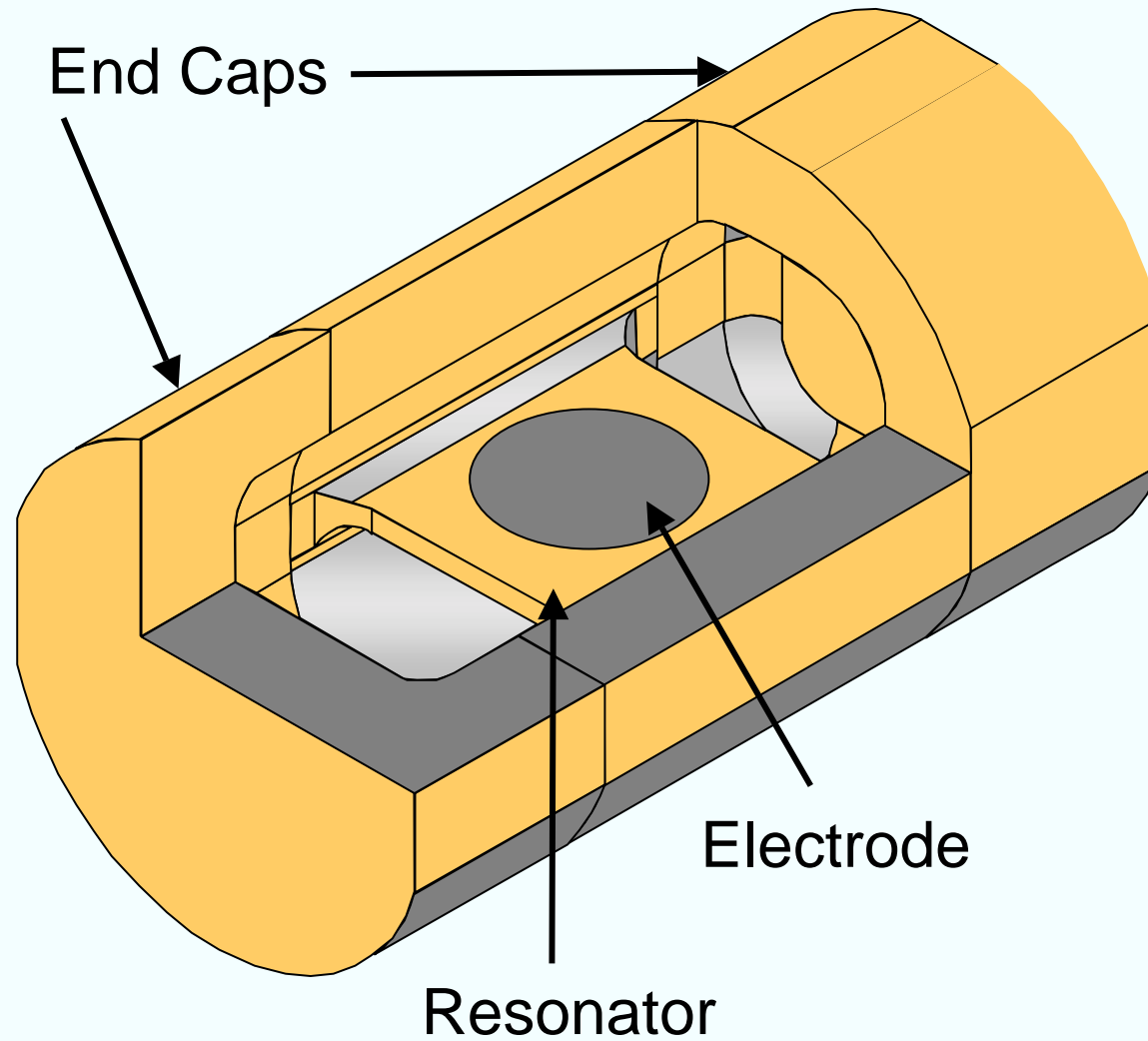

**CHAPTER 10**  
**Proceedings Ordering Information,**  
**Website, and Index**

# IEEE International Frequency Control Symposium PROCEEDINGS ORDERING INFORMATION

<u>NO.</u>	<u>YEAR</u>	<u>DOCUMENT NO.</u>	<u>SOURCE*</u>	<u>NO.</u>	<u>YEAR</u>	<u>DOCUMENT NO.</u>	<u>SOURCE*</u>
10	1956	AD-298322	NTIS	32	1978	AD-A955718	NTIS
11	1957	AD-298323	NTIS	33	1979	AD-A213544	NTIS
12	1958	AD-298324	NTIS	34	1980	AD-A213670	NTIS
13	1959	AD-298325	NTIS	35	1981	AD-A110870	NTIS
14	1960	AD-246500	NTIS	36	1982	AD-A130811	NTIS
15	1961	AD-265455	NTIS	37	1983	AD-A136673	NTIS
16	1962	AD-285086	NTIS	38	1984	AD-A217381	NTIS
17	1963	AD-423381	NTIS	39	1985	AD-A217404	NTIS
18	1964	AD-450341	NTIS	40	1986	AD-A235435	NTIS
19	1965	AD-471229	NTIS	41	1987	AD-A216858	NTIS
20	1966	AD-800523	NTIS	42	1988	AD-A217275	NTIS
21	1967	AD-659792	NTIS	43	1989	AD-A235629	NTIS
22	1968	AD-844911	NTIS	44	1990	AD-A272017	NTIS
23	1969	AD-746209	NTIS	45	1991	AD-A272274	NTIS
24	1970	AD-746210	NTIS	46	1992	92CH3083-3	IEEE
25	1971	AD-746211	NTIS	47	1993	93CH3244-1	IEEE
26	1972	AD-771043	NTIS	48	1994	94CH3446-2	IEEE
27	1973	AD-771042	NTIS	49	1995	95CH3575-2	IEEE
28	1974	AD-A011113	NTIS	50	1996	96CH35935	IEEE
29	1975	AD-A017466	NTIS	51	1997	97CH36016	IEEE
30	1976	AD-A046089	NTIS	52	1998	98CH36165	IEEE
31	1977	AD-A088221	NTIS	53	1999	99CH?????	IEEE

Please check with NTIS or IEEE for current pricing. IEEE members may order IEEE proceedings at half-price.

\*NTIS - National Technical Information Service  
5285 Port Royal Road, Sills Building  
Springfield, VA 22161, U.S.A.  
Tel: 703-487-4650  
Fax: 703-321-8547  
E-mail: [info@NTIS.fedworld.gov](mailto:info@NTIS.fedworld.gov)  
<http://www.fedworld.gov/ntis/search.htm>

\*IEEE - Inst. of Electrical & Electronics Engineers  
445 Hoes Lane  
Piscataway, NJ 08854, U.S.A.  
Tel: 800-678-4333 or 908-981-0060  
E-mail: [customer.services@ieee.org](mailto:customer.services@ieee.org)  
<http://www.ieee.org/ieeestore/ordinfo.html>

Prior to 1992, the Symposium's name was the "Annual Symposium on Frequency Control," and in 1992, the name was IEEE Frequency Control Symposium (i.e., without the "International").

# Frequency Control Web Site

Frequency control information can be found on the World Wide Web at

<http://www.ieee-uffc.org/fc>

Available at this site are the full text of all the papers ever published in the Proceedings of the Frequency Control Symposium, i.e., since 1956, reference and tutorial information, nine books, historical information, and links to other web sites, including a **directory of company web sites.**

## INDEX (A-D)

Acceleration, 3-37, 4-4, 4-58 to 4-77  
Accuracy, 2-23, 4-2, 7-2  
Activity Dips, 3-8, 4-59  
Aging, 4-3 to 4-14, 4-55, 4-90, 6-24, 7-1  
Allan Variance & Allan Deviation, 4-16 to 4-24, 4-30 to 4-36, 4-64, 6-14 to 6-17, 7-1, 7-3  
Altitude, 4-3, 4-90  
Amplitude, 3-6, 4-57 to 4-60  
Amplitude Distribution, 3-6  
Angles of Cut, 3-3, 3-13, 4-41  
Applications, 1-1 to 1-20, 4-73 to 4-74, 8-15, 8-25, 8-26  
ASFC Proceedings, 10-2  
AT-Cut, 3-8, 3-13, 3-23, 4-10 to 4-14, 4-41, 4-43, 4-45, 4-46, 4-59, 4-72, 4-81 to 4-85, 4-88, 4-89  
Atmospheric Pressure, 4-3, 4-90  
Atomic Frequency Standards, 2-8, 2-22 to 2-23, 3-37, 6-23- to 6-24, 6-1 to 7-5  
BCD Time Code, 8-23  
Bending Strains, 4-15  
Bistatic Radar, 1-18  
Bonding Strains, 4-12, 4-14  
Calibration, 8-12, 8-13  
Ceramic Flatpack, 3-5, 3-37, 6-24  
Cesium-Beam Frequency Standard, 2-8, 6-1, 6-9 to 6-11, 6-14, 6-15, 6-19, 6-20, 6-22, 7-1 to 7-5  
Clocks, 4-38, 8-4 to 8-12, 8-19 to 8-22, 8-25, 8-26  
Commercial vs. Military Markets, 1-2, 1-3  
Conversions, 8-21  
Doppler, 1-10, 1-17o 1-19, 8-21  
Doubly Rotated Cuts, 3-13  
Drive Level, 4-57 to 4-60, 4-91

## INDEX (E-I)

Electric Field, 4-90  
Emerging/Improving Technologies, 3-37, 6-25  
Environmental Effects, 4-3, 4-4  
Equivalent Circuit, 3-19, 3-20, 3-21  
f-squared, 3-31  
Fabrication Steps, 3-27  
Failures, 7-6  
Filters, 9-1, 9-2  
Force-Frequency Effect, 4-10 to 4-14  
Frequency Hopping, 1-13 to 1-15  
Frequency Jumps, 4-60  
Frequency Multiplication, 4-27, 4-34 to 4-36, 4-66, 4-73, 4-74  
Frequency vs. Temperature, 3-11 to 3-13, 3-21, 4-37 to 4-51, 4-91, 6-24  
G-sensitivity, 4-4, 4-56, 4-58 to 4-77, 4-91, 3-34  
Global Positioning System (GPS), 1-4, 8-14 to 8-17  
Harmonics, 3-4, 3-7, 3-8, 4-45  
Historical Information, 3-32, 8-6, 8-7  
Humidity, 4-3, 4-90  
Hydrogen Maser, 6-1, 6-12, 6-13  
Hysteresis, 2-23, 4-47,  
Identification Friend or Foe (IFF), 1-12, 1-16,  
Impacts of Technology, 1-12 to 1-19, 4-17, 4-71, 9-17  
Influences on Frequency, 4-3, 4-4, 4-91  
Infrared Absorption, 5-11 to 5-13  
Interactions, 4-91  
Inversion, quartz, 5-17, 5-18

## INDEX (J-O)

Jitter, 4-64, 8-13  
Johnson Noise, 4-19, 4-34  
Jumps, 4-60  
Laser Cooling of Atoms, 6-23  
Lateral Field Resonator, 3-37, 3-38,  
Load Capacitance, 3-20, 3-21, 4-40, 4-44, 4-51 to 4-55  
Load, external, 2-15  
Load Impedance, 3-20, 3-21, 4-3, 4-40, 4-44, 4-51 to 4-55  
Loran, 8-12, 8-14  
Magnetic Field, 4-3, 4-89, 6-9, 6-14, 6-20  
Mathematical Description of a Resonator, 3-10 to 3-12  
MCXO, 2-5, 2-8, 2-19 to 2-21, 3-36, 3-38, 6-24, 7-1, 8-10  
MIFTTI, 8-26  
Milestones in Quartz Technology, 3-32  
Milestones in Timekeeping, 8-7  
Military Requirements, 1-11 to 1-19  
Mixer, 4-27, 4-28  
Modes of Motion, 3-3, 3-4, 3-7, 3-8  
Monolithic Crystal Filter, 9-2  
Motional Parameters, 3-16, 3-23  
Mounting Stress Effects, 4-8 to 4-14  
Navigation, 1-4, 8-15 to 8-17  
Neutrons, Effects of, 4-85, 4-86, 4-89  
Noise, 2-14, 4-3, 4-5, 4-16 to 4-19, 4-17 to 4-26, 4-29 to 4-36 6-14 to 6-21  
Nonlinearity, 2-2, 3-10  
OCXO, 2-5 to 2-8, 2-11, 4-43, 4-44, 4-46, 4-48, 7-1, 7-2, 8-10  
One Pulse Per Second, 8-13, 8-23



## INDEX (O-P)

Optically Pumped Cs Standard, 6-22  
Opto-Electronic Oscillator, 2-23  
Oscillation, 2-2 to 2-4  
Oscillator Categories, 2-6  
Oscillator Circuit Caused Instabilities, 2-10 to 2-15  
Oscillator Circuits, 2-9  
Oscillator Comparison, 7-1 to 7-5  
Oscillator Failures, 7-6  
Oscillator Hierarchy, 2-8  
Oscillator Outputs, 2-10  
Oscillator Selection, 7-7  
Oscillator Specification, 7-7  
Oscillator Types, 2-5 to 2-8  
Oscillators, 2-1 to 2-8, 2-19 to 2-23, 6-23 to 6-24, 7-1 to 7-7  
Oven, 4-43, 4-44, 4-45  
Packaging, 3-18, 3-38  
Phase, 2-2, 2-3, 4-16, 4-25, 7-1 to 7-5  
Phase Detector, 4-28 to 4-29  
Phase Diagram of Silica, 5-18  
Phase Jitter, 4-65  
Phase Noise, 1-8, 1-17, 4-16 to 4-36, 4-62 to 4-69, 4-73, 4-74  
Piezoelectricity, 3-1 to 3-3, 3-9 to 3-11  
Power Requirements, 6-24, 7-1, 7-2  
Power Supply, 2-9, 4-3, 4-89  
Precision, 4-2  
Proceedings, ASFC, 10-2  
Propagation Delay, 8-22

## INDEX (Q-S)

Q, 3-23 to 3-26, 4-19, 4-34, 4-87, 4-88, 5-5, 5-13, 6-1, 6-6, 6-14, 6-15  
Quartz (material), 3-1, 3-12, 5-1 to 5-18  
Quartz Cuts, 3-13, 4-41  
Quartz Inversion, 5-17, 5-18  
Quartz Lattice, 5-5, 5-7, 5-16  
Quartz Phases, 5-18  
Quartz Twinning, 5-14 to 5-16  
Quotations, time, 8-1, 8-27  
Radar, 1-17 to 1-20, 4-18, 4-73, 4-74, 8-22  
Radiation Effects, 4-4, 4-79 to 4-89, 4-91, 5-5, 6-25, 7-5  
Radio, two-way, 1-6  
Random vibration, 4-19, 4-69, 4-71  
Random walk, 4-5, 4-26, 4-33  
RbXO, 2-5, 2-8, 2-22 to 2-23, 3-37, 7-1, 7-2  
Relativistic Time, 8-19 to 8-21  
Resistance, 3-19, 3-20, 3-23, 4-52, 4-56, 4-84  
Resonator Packaging, 3-4, 3-5, 4-90  
Resonator Theory, 3-9 to 3-11  
Resonators, 3-2 to 3-36  
Restart, 4-48  
Retrace, 4-47, 4-48  
Rubidium Frequency Standard, 2-8, 2-22, 3-37, 6-23 to 6-24, 6-1, 6-3, 6-5, 6-7, 6-8, 6-15, 6-17, 7-1 to 7-5  
SAW, 4-35 to 4-37, 9-3  
SC-Cut, 2-19 to 2-20, 3-13, 3-35 to 3-37, 4-13, 4-42 to 4-44, 4-46, 4-55, 4-60, 4-72, 4-76, 4-83, 4-88, 6-25  
Sensors, 9-4, 9-5  
Shock, 4-3, 4-4, 4-78, 6-24  
Short Term Instability Causes, 4-19, 6-15

## INDEX (S-T)

Short Term Stability, 4-3 to 4-5, 4-16 to 4-36, 6-14 to 6-21, 7-1 to 7-4  
Short-Term Stability Measures, 4-17 to 4-21, 4-25  
Shot Noise, 4-18, 6-15  
Signal-to-noise ratio, 4-34, 6-15  
Silica, 5-18  
Space Exploration, 1-10  
Specifications, 7-7, 7-8  
Spectral Densities, 4-25, 4-26, 4-29 to 4-37  
Spread Spectrum, 1-12 to 1-16  
Stability, 2-3, 2-4, 4-2 to 4-90, 7-3, 7-4  
Strains, 4-10 to 4-14  
Surface Acoustic Wave Devices, 4-35 to 4-37, 9-3  
Sweeping, 5-9, 5-10  
TCXO, 2-5 to 2-8, 3-20, 3-21, 4-39, 4-47, 4-49, 4-51, 7-1, 7-2, 8-10  
Telecommunication, 1-7  
Thermal Expansion of Quartz, 4-9  
Thermal Hysteresis, 4-47, 6-23  
Thermal Transient Effect, 4-43, 4-46, 4-88, 4-91  
Time & Frequency Subsystem, 8-25, 8-26  
Time, 8-1 to 8-28  
Time Code, 8-23, 8-24  
Time Constant, 3-23 to 3-27  
Time Domain - Frequency Domain, 4-17  
Time Errors, 8-8 to 8-11  
Time Quotations, 8-27

## INDEX (T-Z)

Time Scales, 8-18  
Time Transfer, 8-12 to 8-16, 8-20, 8-21  
Timing Signal, 8-23, 8-24  
Trim Effect, 4-49, 4-51  
Tunability, 2-4, 3-20  
Tuned circuit, 2-13  
Tuning fork, 3-33 to 3-36, 4-40  
Twinning, 5-14 to 5-16  
Two-way Radio, 1-6  
Universal Time, 8-18  
UTC, 8-18  
Utility Fault Location, 1-9  
VCXO, 2-5, 3-19  
Vibration, 4-4, 4-18, 4-54 to 4-77  
Vibration-Induced Sidebands, 4-65 to 4-68, 4-77, 4-91  
Vibration Compensation, 4-76, 4-77  
Vibration Isolation, 4-75  
Vibration Resonance, 4-71  
Very Long Baseline Interferometry (VLBI), 1-10  
Warmup, 4-46, 7-1  
Wearout Mechanisms, 7-5  
Wristwatch, 3-32 to 3-36, 4-40  
Zero Temperature Coefficient Cuts, 3-11 to 3-13